

Operation Manual

AFX Series® – Rev 1.3.8

P/N 160620-10

AFX Series® Programmable Power Source

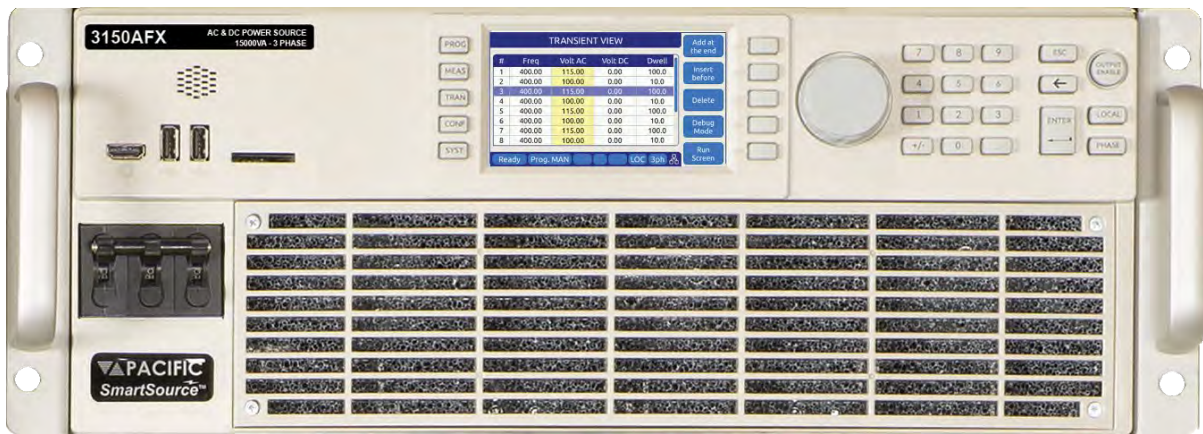

PACIFIC POWER SOURCE

Worldwide Supplier of Precision Programmable Power

Copyright © 2023, Pacific Power Source, Inc. (PPS) • All Rights Reserved • No reproduction without written authorization from PPS.

GENERAL DISCLAIMER

Pacific Power Source, Inc. reserves the right to revise this documentation and to make changes in content from time to time without obligation on the part of Pacific Power Source, Inc. to provide notification of such revision or change. This publication may include technical or other inaccuracies or typographical errors. Furthermore, changes are periodically added to the information herein; these changes will be incorporated in new editions of the publication. Pacific Power Source, Inc. may make improvements and/or changes in the operation, features, functions and/or technical specifications described in this publication at any time.

Table of Contents

1	Contact Information	15
2	Safety & Warranty Information	16
2.1	Limited Warranty	16
2.2	Service and Spare Parts Limited Warranty	16
2.3	Safety Information.....	16
2.4	Safety Notices	18
3	Product Overview	23
3.1	General Description.....	23
3.2	Product Features	24
3.3	Block Diagram	25
3.4	Controller Description	26
3.5	Measurement Read-back	26
3.6	Accessories Included (Ship Kit)	26
3.7	Remote Control Interfaces.....	26
4	Technical Specifications	27
4.1	Single Chassis Models.....	27
4.2	Multiple Chassis Models	27
4.3	AC Output Mode	28
4.3.1	Programmable Output Impedance Ranges by Phase Mode.....	30
4.3.2	Programmable Impedance operation	30
4.3.3	Extended Frequency Ranges – Supplemental specs	30
4.3.4	Temporary Current Overload	33
4.3.5	AC Voltage and Current Output Charts	34
4.3.6	Extended AC Voltage Ranges – Supplemental specs	35
4.4	DC Output Mode	37
4.4.1	DC Voltage and Current Output Charts	37
4.5	Protection Modes.....	38
4.6	Metering	39
4.7	Other Measurements.....	40
4.8	Transients.....	40
4.9	AC Input	41
4.10	Dimensions & Weight	41
4.11	Environmental	42
4.12	Safety & Regulatory.....	42
4.13	Digital Interfaces.....	43
4.14	Auxiliary I/O	44
4.15	Transformer Output Voltage Range (T Option)	46
4.15.1	Available T Option Rating Versions.....	46
4.15.2	Technical Specifications 400V Range.....	47
4.16	Series Output Voltage Range (S Option)	49
4.16.1	Series Mode AFSX description	49
4.16.2	AFX & AFX with Option W output connector pin assignments.....	49
4.16.3	Series versus Parallel Connection Modes.....	50
4.16.4	SPMS Series Configuration switch option	51
4.16.5	Standard Series Output Cabinet System Configurations.....	52
4.16.6	Selecting the Series Mode Configuration	53
4.17	IEC413 Option	54
5	Unpacking and Installation	55

5.1	Inspection	55
5.2	Lifting and Carrying Instructions	55
5.3	Verify Correct AC Input Line Voltage	57
5.4	AC Input Connections	58
5.5	Grounding Requirements	61
5.5.1	Chassis Ground Connection Required	61
5.5.2	Output Neutral Grounding	62
5.6	AC Input Circuit Breaker	62
5.7	Bench Use	63
5.8	Rack Mounting	63
5.9	Airflow	63
5.10	Sound Levels	64
5.11	Cleaning	65
5.12	Air Intake Filter Removal and Cleaning	65
5.12.1	Air Filter Removal	66
5.12.2	Filter Cleaning	66
5.12.3	Air Filter Installation	66
5.13	Liquids	66
5.14	Load Connections	67
5.14.1	Output Wiring and Recommended Wire Sizing	67
5.14.2	Three Phase Wye or Split Phase Load Output Connection	68
5.14.3	Three Phase Delta Load Output Connection	71
5.14.4	AFX Series & AFX with Option W Output Load Connections	74
5.14.5	Single Phase Load Output Connection	74
5.14.6	External Voltage Sense Connections	77
5.14.7	Powering Up	79
5.14.8	In Case of Malfunction	79
5.15	Cabinet Systems Installation	80
5.15.1	Standard Cabinet Sizes	80
5.15.2	Tools Required	80
5.15.3	Dimensions	81
5.15.4	Cabinet System AC Input Connections	82
5.15.5	Recommended AC Input Wire Strip Lengths	82
5.15.6	Cabinet System AC Input Neutral	84
5.15.7	Cabinet System Grounding	84
5.15.8	Recommended AC Output Wire Strip Lengths	85
5.15.9	Cabinet Load Connections – Three Phase WYE Loads	85
5.15.10	Cabinet Load Connections – Three Phase Delta Loads	86
5.15.11	Cabinet Load Connections – Single Phase Loads	87
5.16	AFX Cabinet Systems Turn ON and Turn OFF Procedures	88
5.16.1	Cabinet Power Turn ON using Circuit Breakers	88
5.16.2	Cabinet Power Turn OFF using Circuit Breakers	88
5.17	Cabinet System Options	90
5.17.1	-OCS: Output Control Switch Option	90
5.17.2	-EPO: Emergency Power Off Option	91
5.17.3	-MRC: Mode Relay Control Option	91
5.17.4	-28UX Option	91
5.17.5	-Transformer Options for Cabinet Systems	92
5.18	Interface Options	93
5.18.1	Rear Panel Connector Locations - “L” Versions	93
5.18.2	Rear Panel Connector Locations - “A” Versions	94
5.18.3	Rear Panel Connector Locations - “AG” Versions	94
5.18.4	USB Device Interface	94

5.18.5	RS232 Serial Interface.....	95
5.18.6	GPIB Device Interface (Option G).....	97
5.18.7	Remote Inhibit or Enable Input.....	98
5.18.8	External MODE Relay Control.....	99
5.18.9	LAN Interface.....	100
5.18.10	System Interface Bus Connectors.....	100
5.19	Multi-Unit Parallel Operation.....	101
5.19.1	Load Connections on Parallel Systems.....	101
5.19.2	Parallel System Bus Connection.....	101
5.19.3	Master / Master Paralleling.....	102
5.20	Multi-Cabinet Parallel Operation Guidelines.....	103
5.20.1	Output Wiring.....	103
5.20.2	System Grounding.....	104
5.21	Transformer Options.....	105
5.21.1	T Option 4U Chassis.....	105
5.21.2	Rack Mount T Option Installation.....	106
5.21.3	Unpacking T Option Chassis.....	107
5.21.4	Cabinet Installation.....	107
5.21.5	T Option Chassis Rear Panel Connectors.....	108
5.21.6	AFX Power Source to T Option Connections.....	110
6	Front Panel Operation.....	111
6.1	Front Panel Layout.....	111
6.1.1	Keyboard Buttons.....	112
6.1.2	Shuttle Knob.....	113
6.1.3	PC Monitor Output.....	113
6.1.4	USB Host Ports.....	113
6.1.5	SD Card Memory Slot.....	113
6.2	OUTPUT ENABLE Button.....	114
6.2.1	OUTPUT State Indication.....	114
6.2.2	Energy Savings Modes.....	114
6.2.3	Output On Response Times.....	114
6.3	Menu Keys.....	115
6.4	PROG – PROGRAM Screens.....	116
6.4.1	Power On Settings.....	117
6.4.2	PROGRAM Output Parameters.....	117
6.4.3	Phase Rotation / Phase Sequence.....	118
6.4.4	Direct Data Entry - Presets.....	119
6.4.5	Customizing Output Programming Preset Soft Key Values.....	120
6.4.6	Changing Shuttle Programming Resolution.....	120
6.4.7	Phase Mode Selection.....	121
6.4.8	PROGRAM Soft Keys.....	122
6.4.9	Peak Current Protection Minimum Setting.....	124
6.4.10	Available Waveforms.....	126
6.4.11	Waveform Smoothing Filter.....	128
6.4.12	AUTO RMS Function – Steady State.....	129
6.4.13	Extended AC Voltage Range Operation.....	131
6.5	MEAS – MEASUREMENTS Screens.....	134
6.5.1	Measurements Screens.....	134
6.5.2	Scope Measurements.....	135
6.5.3	Harmonic Measurements.....	136
6.5.4	Measurement Screen Soft Keys.....	137
6.5.5	Measurement Data Logging.....	139
6.6	TRAN- TRANSIENTS Screens.....	140
6.6.1	LIST Mode.....	140

6.6.2	LIST Parameters	141
6.6.3	LIST Transient Edit Mode	144
6.6.4	LIST Transient Execution Modes	145
6.6.5	LIST Transient Entry Modes	147
6.6.6	Multiple User Waveforms in LIST Transients	148
6.6.7	STEP or RAMP Modes.....	149
6.6.8	STEP or RAMP Parameters.....	150
6.6.9	STEP or RAMP Transient Execution Modes.....	151
6.6.10	PULSE Mode.....	152
6.6.11	PULSE Parameters	153
6.6.12	PULSE Transient Execution Modes	154
6.6.13	AUTO RMS Function – Transients.....	155
6.7	CONF – CONFIGURATION Screens	156
6.7.1	UNIT CONFIGURATION Screens.....	158
6.7.2	USER LIMITS SETTINGS Screen.....	162
6.7.3	RAMP TIME & SLEW RATE SETTINGS Screen	163
6.7.4	PROGRAM MEMORY Screen	165
6.7.5	CSC CONFIGURATION Screen	166
6.7.6	TRANSIENT SETTINGS Screen.....	167
6.7.7	OUTPUT IMPEDANCE Screen.....	168
6.7.8	USER PRESETS Screen.....	169
6.8	SYST – SYSTEM Screens.....	171
6.8.1	SYSTEM MENU 1.....	172
6.8.2	SYSTEM MENU 2.....	172
6.8.3	ERROR / EVENT QUEUE Screen	173
6.8.4	FAULT INFORMATION Screen.....	173
6.8.5	INTERFACE Screen	174
6.8.6	UNIT INFORMATION Screen	187
6.8.7	CONNECTED UNITS Screen	188
6.8.8	SCPI CONSOLE.....	189
6.8.9	SYSTEM SETTINGS Screen	190
6.8.10	MEMORY MANAGEMENT Screen	191
6.8.11	CALIBRATION MENU Screen.....	196
6.8.12	FIRMWARE UPDATE Screen.....	197
6.8.13	REMOTE SUPPORT Screen	198
7	Rear Panel, Connectors and Protection	199
7.1	OUTPUT Terminals	199
7.1.1	Output Power Connector Rating and Isolation.....	200
7.1.2	Wire Size.....	200
7.1.3	Connecting a UUT.....	200
7.2	External Voltage Sense Input Terminals	201
7.2.1	External Voltage Sense Connector Rating and Isolation	202
7.2.2	Load Connection without External Voltage Sense.....	202
7.2.3	Load Connection with External Voltage Sense.	202
7.3	Auxiliary I/O	203
7.3.1	Auxiliary I/O Functions	203
7.3.2	DB25 Connector AUX I/O Pin locations	204
7.3.3	I/O Signal Table by pin number.....	205
7.3.4	I/O Signal Table by Function	206
7.3.5	Dedicated Function Digital Inputs.....	207
7.3.6	Transient Trigger Input.....	209
7.3.7	External or Line Sync Input.....	210
7.3.8	Digital Output control signals.....	213
7.3.9	User Programmable Digital signals.....	216

7.3.10	Analog I/O Descriptions.....	218
7.3.11	12 DC Power Supply	220
7.3.12	RS232 Description.....	220
7.3.13	Front Panel Operation of AUX I/O Functions	221
7.4	System Interface Bus Connectors.....	228
8	Remote Control Programming.....	229
8.1	Overview	229
8.1.1	Programming Conventions and Notations.....	229
8.1.2	Command Terminators	231
8.2	Remote Control Command Descriptions by Subsystem	231
8.3	Calibration Commands.....	232
8.3.1	AFX Calibration Commands	232
8.3.2	UPC Mode Specific commands.....	234
8.3.3	AUX I/O Interface Calibration Commands	234
8.4	Measurement Commands.....	235
8.4.1	Voltage Measurement Commands	235
8.4.2	Frequency Measurement Commands	236
8.4.3	Current Measurement Commands	236
8.4.4	Power Measurement Commands	238
8.4.5	KWh Measurement Commands	239
8.4.6	Other Measurement Commands	241
8.4.7	Measurement Data Logging Commands	242
8.4.8	Waveform Capture Commands.....	245
8.4.9	Harmonic Measurements Commands.....	247
8.4.10	Measurement Resolution Setting Commands.....	252
8.5	Output Control Commands	254
8.6	Program Commands	259
8.6.1	Program Control Commands	259
8.6.2	Execution Commands.....	272
8.6.3	Transient Segments Commands.....	273
8.6.4	Memory Management Commands.....	278
8.7	Source Commands	281
8.7.1	Source Configuration Programming Commands.....	281
8.7.2	Voltage Programming Commands	287
8.7.3	Frequency Programming Commands.....	294
8.7.4	Current Programming Commands	296
8.7.5	Phase Programming Commands	298
8.7.6	Waveform Programming Commands	300
8.7.7	Voltage Protection Programming Commands.....	308
8.7.8	Current Protection Programming Commands.....	310
8.7.9	Power Protection Programming Commands.....	316
8.7.10	Impedance Programming Commands	321
8.7.11	STEP Transient Commands	323
8.7.12	PULSE Transient Commands.....	343
8.7.13	IEC413 Option Interharmonics Commands	355
8.8	Status Commands	359
8.9	System Commands.....	361
8.9.1	System Error Commands	361
8.9.2	System Information Commands.....	363
8.9.3	System Interface Commands.....	367
8.9.4	System Configuration Commands	371
8.9.5	Parallel System Commands.....	373
8.9.6	System Sanitization Commands	374
8.9.7	Communication LAN Commands	374

8.9.8	Communication Serial Port Commands	379
8.9.9	Communication USB Commands	381
8.9.10	Communication GPIB Commands	382
8.9.11	System Firmware Commands.....	384
8.9.12	System Remote Access Commands	385
8.9.13	System Regional Setting Commands.....	387
8.9.14	Miscellaneous System Commands.....	388
8.10	Auxiliary I/O System Commands	389
8.10.1	System Analog & Digital IO Commands	389
8.10.2	SOURce:SYNChronize Commands	402
8.10.3	PROGram:TRANsient Triggers Commands	405
8.10.4	AUX I/O Calibration Commands	407
8.11	Web Browser Test Sequence Commands.....	411
8.12	AFXS Series Mode Commands.....	414
8.13	IEEE488.2 Common Commands.....	417
8.14	Status and Events Registers	421
8.14.1	Status Byte Register (STB)	421
8.14.2	Status Event Register (ESR)	423
8.14.3	SCPI Status Registers	424
9	USB Driver Installation.....	426
9.1	Overview	426
9.2	Installation	426
10	LAN Interface Configuration	428
10.1	Overview	428
10.2	Web Browser Interface	428
10.3	Access Control	430
10.3.1	Browser Access Control.....	431
10.3.2	Front Panel Access Control	435
10.4	Web Browser Interface	436
10.5	Available Web Interface Menu Tree	436
10.6	Home Screen	437
10.6.1	SCPI Console Command Line Interface	437
10.6.2	Status Byte Display	438
10.6.3	Browser Status Bar	439
10.6.4	Operation Manual PDF.....	439
10.7	Source Control Screens	440
10.7.1	Program.....	441
10.7.2	Protections.....	442
10.7.3	Transients.....	443
10.7.4	Interharmonic	449
10.7.5	Program Memory	450
10.7.6	Waveform	451
10.7.7	Waveform Editor	452
10.7.8	Test Sequence.....	457
10.7.9	SCPI Script	459
10.8	Measurement Screens	461
10.8.1	Monitor	462
10.8.2	Real-Time Plot.....	463
10.8.3	V/I Plot.....	464
10.8.4	Data Logger.....	465
10.8.5	Scope.....	466
10.8.6	Harmonics	468
10.9	Configuration Screens	469

10.9.1	Unit Settings.....	470
10.9.2	User Limits & Presets.....	471
10.9.3	Ramp Time & Slew Rate.....	472
10.10	System Screens.....	473
10.10.1	Error/Event Queue	474
10.10.2	Fault List	475
10.10.3	Error/Event List.....	476
10.10.4	Interface Setup	477
10.10.5	Access Control.....	478
10.10.6	Digital & Analog IO's.....	479
10.10.7	Remote Interface (Virtual Front Panel)	483
10.10.8	Unit Information.....	484
10.10.9	Connected Units	485
10.10.10	Memory Browser.....	486
10.10.11	Calibration.....	487
10.10.12	Remote Support	488
10.10.13	Import / Export	488
10.10.14	Firmware Update.....	489
10.10.15	Sanitize and Reboot.....	490
10.11	Additional Functions.....	490
10.11.1	Sharing Options – FTP & SAMBA	490
11	Calibration.....	491
11.1	Calibration Interval.....	491
11.2	Closed Case User Calibration	491
11.3	Equipment Required	491
11.4	Calibration Procedures.....	492
11.4.1	Voltage Calibration - Offset.....	492
11.4.2	Current Calibration - Offset.....	493
11.4.3	Voltage Calibration - Gain	494
11.4.4	Current Gain Calibration Setup Diagrams	495
11.4.1	Current Calibration Load Values.....	496
11.4.2	Current Calibration - Gain	497
11.4.3	Exit Calibration Mode.....	497
12	Warnings & Error Messages	498
12.1	Preface	498
12.2	Errors & Warnings Messages in Numeric Order.....	498
13	Service and Maintenance	521
13.1	Warnings.....	521
13.2	Authorized Service Centers.....	522
14	ModBus TCP Server / Slave Interface.....	523
14.1	TCP ModBus Interface.....	523
14.2	Modbus TCP Register Tables	523
14.3	ModBus Control Example using Python.....	537
15	CE MARK Declaration of Conformity.....	538
	Index	539

Table of Tables

Table 3-1: Included Accessories	26
Table 3-2: Remote Control Interface	26
Table 4-1: Programmable Impedance Ranges by Phase mode	30
Table 5-1: AC Input Wire Size Table	59
Table 5-2: Available AFX Cabinet Options	90
Table 5-3: Remote Control Interface Connector Locations on Rear Panel (A Versions).....	94
Table 5-4: Remote Control Interface Connector Locations on Rear Panel (A Versions w GPIB)	94
Table 5-5: RS232 DB25 Tx and Rx Pin Locations	95
Table 5-6: Standard RS232 DB9 Pin Assignments.....	96
Table 5-7: GPIB Interface Connector Pin Assignments.....	97
Table 5-8: Transformer Option Chassis, Rear Panel Connectors.....	109
Table 6-1: Available Menu Keys.....	115
Table 6-2: Available Output Parameters on PROGRAM screen.....	117
Table 6-3: Changing Programming Resolution	120
Table 6-4: PROGRAM screen soft keys	123
Table 6-5: Available Included AFX Series® Waveforms	127
Table 6-6: Measurement Screen Soft Keys.....	138
Table 6-7: Available LIST Transient Parameters	141
Table 6-8: Voltage Transient List for Example 1	142
Table 6-9: RTCA/DO160 Section 16 test number 16.5.2.1d	143
Table 6-10: Voltage Transient List for Example 1	143
Table 6-11: Available TRANSIENT EDIT screen soft keys	145
Table 6-12: Available TRANSIENT DEBUG screen soft keys	145
Table 6-13: Available TRANSIENT PROGRAM screen soft keys	146
Table 6-14: Available STEP Transient Parameters	150
Table 6-15: Available STEP PROGRAM screen soft keys.....	150
Table 6-16: Available STEP EXECUTION screen soft keys	151
Table 6-17: Available STEP Transient Parameters	153
Table 6-18: Available STEP PROGRAM screen soft keys.....	153
Table 6-19: Available STEP PROGRAM screen soft keys.....	154
Table 6-20: Available UNIT CONFIGURATION 1 screen soft keys	160
Table 6-21: Available UNIT CONFIGURATION 2 screen soft keys	161
Table 6-22: Available USER LIMITS SETTINGS screen soft keys	162
Table 6-23: Available RAMP TIME & SLEW RATE SETTINGS screen soft keys	164
Table 6-24: Available SLEW RATE SETTINGS screen soft keys	166
Table 6-25: Available CSC CONFIGURATION screen soft keys	166
Table 6-26: Available TRANSIENT SETTINGS screen soft keys	167
Table 6-27: Available PROGRAMMABLE IMPEDANCE screen soft keys	168
Table 6-28: Available USER INTERFACE screen soft keys.....	176
Table 6-29: Available USER INTERFACE screen soft keys.....	179
Table 6-30: Available ETHERNET INTERFACE SETUP screen soft keys	181
Table 6-31: Available SERIAL INTERFACE SETUP screen soft keys	182
Table 6-32: Available USB INTERFACE SETUP screen soft keys	183
Table 6-33: Available GPIB INTERFACE SETUP screen soft keys	184

Table 6-34: Available UNIT INFORMATION screen soft keys.....	187
Table 6-35: Available PARALLEL UNITS screen soft keys	188
Table 6-36: Available SYSTEM SETTINGS screen soft keys	190
Table 6-37: Available CALIBRATION MENU screen soft keys.....	197
Table 6-38: Available FIRMWARE UPDATE screen soft keys	197
Table 6-39: Available LOGGING TOOL screen soft keys.....	198
Table 7-1: Auxiliary I/O DB25 Connector Pin numbers and Signals by DB25 pin number.....	205
Table 7-2: Auxiliary I/O DB25 Connector Pin numbers and Signals by Signal Name.....	206
Table 7-3: Default Analog Output Functions	219
Table 7-4: AUX I/O Analog Input assignable Commands.....	222
Table 7-5: AUX I/O Digital Output assignable Events or Conditions.....	225
Table 8-1: Available SCPI Command Subsystems	231
Table 8-2: Available Included AFX Series® Waveforms	301
Table 8-3: Mandatory IEEE488.2 Common Commands	417
Table 8-4: Status Byte Register (STB)	421
Table 8-5: Status Event Register (ESR).....	423
Table 10-1: Supported Script Entries.....	459
Table 11-1: Required Calibration Equipment	491
Table 11-2: Setup for Voltage Offset Calibration	492
Table 11-3: Calibration Load Values by Model and Phase Mode	496
Table 12-1: Warnings and Error Messages Listing.....	520

Table of Figures

Figure 2-1: EMI AC Input Filter Residual Voltage Check after disconnecting AC Mains power	21
Figure 3-1: AFX Series Model Number Decoder	23
Figure 3-2: AFX Series® Basic Block Diagram	25
Figure 4-1: Output Voltage distortion into full R Load as a function of Frequency	29
Figure 4-2: 1.00Hz ~ 15.00Hz Freq. Range Power Rating in 3 Phs Mode	31
Figure 4-3: 1200Hz ~ 3000Hz Freq. Range Voltage vs. Current- 3150AFX in 3 Phs Mode	32
Figure 4-4: 1200Hz ~ 3000Hz Extended Freq. Range Power - 3150AFX in 3 Phs Mode	32
Figure 4-5: Current Overload vs. Time.....	33
Figure 4-6: AC Mode Voltage/Current range, AFX Models - 3 or 2-phase mode.	34
Figure 4-7: AC Mode Voltage/Current range, AFX Models – 1 phase mode.	34
Figure 4-8: Extended AC Voltage/Current Range, AFX Models – 3 or 2 phase mode	36
Figure 4-9: Extended AC Voltage/Current Range, AFX Models – 1 phase mode.....	36
Figure 4-10: DC Mode Voltage/Current range, AFX Models- 3 or 2 phase mode.	37
Figure 4-11: DC Mode Voltage/Current range, AFX Models - 1 phase mode.....	38
Figure 4-12: Dimension Drawing AFX Series® 15KW Model.....	42
Figure 4-13: Rack Mount Chassis for 6kVA to 15kVA Transformer Option	46
Figure 4-14: Voltage vs Current Rating 400V Range – 3 Phase Mode.....	48
Figure 4-15: Voltage vs Current Rating 400V Range – 1 Phase Mode.....	48
Figure 4-16: 60KVA AFXS Series with SPMS Option.....	49
Figure 4-17: Standard AFX model vs AFXS & AFX-W Model Ouput Connector pins.....	49
Figure 4-18: Parallel Configuration – 30 kVA/kW 300Vac LN / 520Vac LL	50
Figure 4-19: Series Configuration – 30 kVA/kW 600Vac LN / 1040Vac LL.....	50
Figure 4-1: Model 5L18-36 VI Curve	55
Figure 5-2: Exploded view of AFX unit packaging.....	56
Figure 5-3: Rear Panel Layout.....	60
Figure 5-4: AC Input Terminal Block - Rear Panel.....	60
Figure 5-5: Grounding Floating Neutral Output	62
Figure 5-6: Air Intake Filter Removal	65
Figure 5-7: Air Intake Filter and Filter Panel.....	66
Figure 5-8: Three Wye or Split phase Load Output Connections – Internal Voltage Sense	69
Figure 5-9: Three phase Wye or Split phase Load Output Connections – External Voltage Sense	70
Figure 5-10: Three phase Delta Load Output Connections – Internal Voltage Sense	72
Figure 5-11: Three phase Delta Load Output Connections – External Voltage Sense.....	73
Figure 5-12: Optional AFX Single Phase Shorting Adaptor assembly	75
Figure 5-13: Single phase Load Output Connections.....	76
Figure 5-14: AFX A Version External Voltage Sense Connector.....	78
Figure 5-15: AFX Cabinet Dimensions.....	81
Figure 5-16: AFX Cabinet AC Input Connection Diagram.....	83
Figure 5-17: WYE Load Connection Diagram.....	85
Figure 5-18: Delta Load Connection Diagram.....	86
Figure 5-19: Single Phase Load Connection Diagram	87
Figure 5-20: AFX Cabinet System Power ON and OFF Sequences	89
Figure 5-21AFX “AG” Version Cabinet -OCS Option Wiring Diagram	90
Figure 5-22: AFX “L” Version Cabinet -OCS Option Wiring Diagram	91

Figure 5-23: Remote Control Interface Connector Locations on Rear Panel (L Versions).....	93
Figure 5-24: Remote Inhibit Control Screen.....	98
Figure 5-25: Remote Inhibit Pins on DB9 for AFX-2L and AFX-4L Versions.....	98
Figure 5-26: AFX Series® Rear Panel Layout.....	100
Figure 5-27: Parallel Mode Bus Connections using parallel bus cable.....	102
Figure 5-28: Multi-Cabinet Parallel Configuration Output Wiring - 3 Phase.....	104
Figure 5-29: Rack Mount Chassis for 6kVA to 15kVA Transformer Option.....	105
Figure 5-30: Interconnections between AFX Power Source and Transformer Option Chassis.....	110
Figure 6-1: AFX Series® Front Panel View.....	111
Figure 6-2: PROGRAM Screen.....	117
Figure 6-3: Three Phase AC mode Default Phase Rotation.....	118
Figure 6-4: Three Phase AC mode Reversed Phase Rotation.....	119
Figure 6-5: Phase Mode Data Entry Status Field.....	121
Figure 6-6: Waveform with no Smoothing Filter Applied.....	128
Figure 6-7: Same Waveform with maximum smoothing Filter Applied.....	128
Figure 6-8: Enable Vac extended operating range to 312Vac.....	132
Figure 6-9: Three Phase Measurement Screens.....	134
Figure 6-10: Single Phase Measurement Screens for Phase A and B.....	134
Figure 6-11: Voltage Transient Example 1.....	142
Figure 6-12: RTCA/DO160 Section 16 test number 16.5.2.1d.....	143
Figure 6-13: Blank TRANSIENT PROGRAM screen.....	144
Figure 6-14: TRANSIENT VIEW Edit Mode.....	144
Figure 6-15: TRANSIENT Debug mode screen.....	145
Figure 6-16: Transient shown in STEP Entry Mode.....	147
Figure 6-17: Transient shown in SEGMENT Entry Mode.....	147
Figure 6-18: Available User Waveforms in Transients.....	148
Figure 6-19: USER LIMIT SETTINGS Screen.....	162
Figure 6-20: RAMP TIME & SLEW RATE SETTINGS Screen.....	163
Figure 6-21: PROGRAM MEMORY screen.....	165
Figure 6-22: CSC CONFIGURATION screen.....	166
Figure 6-23: SYSTEM MAIN MENU 1.....	171
Figure 6-24: SYSTEM MAIN MENU 2.....	171
Figure 6-25: ERROR & EVENT QUEUE Screen.....	173
Figure 6-26: FAULT INFORMATION screen.....	173
Figure 6-27: INTERFACE SETUP Screen.....	174
Figure 6-28: ETHERNET INTERFACE SETUP Screen.....	180
Figure 6-29: SERIAL INTERFCE SETUP Screen.....	182
Figure 6-30: USB INTERFACE SETUP Screen.....	183
Figure 6-31: USB INTERFACE SETUP Screen.....	184
Figure 6-32: REMOTE INHIBIT Setup Screen.....	185
Figure 6-33: UNIT INFORMATION Screen.....	187
Figure 6-34: CONNECTED UNITS Screen.....	188
Figure 6-35: SYSTEM SETTINGS Screen.....	190
Figure 6-36: MEMORY MANAGMENT Screen.....	191
Figure 6-37: CALIBRATION MENU Screen.....	196
Figure 6-38: FIRMWARE UPDATE Screen.....	197

Figure 6-39: REMOTE SUPPORT Screen	198
Figure 6-40: Remote Support REPORT Screen	198
Figure 7-1: Rear Panel AUX I/O DB25 Connector Location	203
Figure 7-2: DB25 Connector AUX I/O Pin Locations	204
Figure 7-3: External Trigger Input Timing	209
Figure 7-4: External Sync Input Pulses	211
Figure 7-5: External Sync Input Sync Status Indication	212
Figure 7-6: External Sync Input Sync Lost Status Indication	212
Figure 7-7: Transient Trigger Output Pulse	214
Figure 7-8: Function Strobe Output Pulse	214
Figure 7-9: Phase A Zero Phase Sync Output Pulse	215
Figure 8-1: Energy Saving Modes and Output Commands State Diagram	254
Figure 8-2: OUTP:ZERO Command Ramp and Dwell settings	258
Figure 8-3: Status Byte Logical Model	422
Figure 8-4: Standard Event Register (ESR) Model	423
Figure 8-5: SCPI Status Registers Model	425
Figure 9-1: PPST USB Drivers visible in Windows Device Manager	427
Figure 10-1: LXI Web Server Home Screen	429
Figure 10-2: ACCESS CONTROL Dialog Screen	431
Figure 10-3: Remote Access Control Request Dialog	432
Figure 10-4: Remote Access Control IP Filter screen	433
Figure 10-5: Waveform Edit defined using 4 data points	453
Figure 10-6: Waveform Edit defined using 16 data points	453
Figure 11-1: Voltage Calibration Equipment Setup – 1 or 3 Phase Mode – Phase A	494
Figure 11-2: Current Calibration Equipment Setup – 3 Phase Mode – Phase A	495
Figure 11-3: Current Calibration Equipment Setup – 1 Phase Mode	496

1 Contact Information

AMERICA / CANADA

Pacific Power Source

2802 Kelvin Avenue, Suite 100

Irvine, CA 92614

USA

Phone: +1(949) 251-1800

Fax: +1 (949) 756-0756

Email: support@pacifcepower.com

EUROPE

Pacific Power Source Europe GmbH.

Binzigstraße 21

77876 Kappelrodeck

Germany

Phone: +49(0)7842-99722-20

Fax: +49(0) 7842-99722-29

Email: info@pacificpower.eu

CHINA

PPST Shanghai Co. Ltd.

4 floors , building 2, No. 2185 Lai Fang Road

Jiu Ting Town, Song Jiang District

Shanghai 201615

Phone: +86-21-6763-9223

Fax: +86-21-5763-8240

Email: support@pacifcepower.comWeb: <https://pacificpower.com>

2 Safety & Warranty Information

2.1 Limited Warranty

Pacific Power Source, Inc. (PPS) warrants each unit to be free from defects in material and workmanship. For the period of two (2) years from the date of shipment to the purchaser, PPS will either repair or replace, at its sole discretion, any unit returned to the PPS factory in Irvine, California or one of its designated service facilities. It does not cover damage arising from misuse of the unit or attempted field modifications or repairs. This warranty specifically excludes damage to other equipment connected to this unit.

Upon notice from the purchaser within (30) days of shipment of units found to be defective in material or workmanship, PPS will pay all shipping charges for the repair or replacement. If notice is received more than thirty (30) days from shipment, all shipping charges shall be paid by the purchaser. Units returned on debit memos will not be accepted and will be returned without repair.

This warranty is exclusive of all other warranties, expressed or implied.

2.2 Service and Spare Parts Limited Warranty

PPS warrants repair work to be free from defects in material and workmanship for the period of ninety (90) days from the invoice date. This Service and Spare Parts Limited Warranty applies to replacement parts or to subassemblies only. All shipping and packaging charges are the sole responsibility of the buyer. PPS will not accept debit memos for returned power sources or for subassemblies. Debit memos will cause return of power sources or assemblies without repair.

This warranty is exclusive of all other warranties, expressed or implied.

2.3 Safety Information

This chapter contains important information you should read BEFORE attempting to install and power-up PPS Equipment. The information in this chapter is provided for use by experienced operators. Experienced operators understand the necessity of becoming familiar with, and then observing, life-critical safety and installation issues. Topics in this chapter include:

- Safety Notices
- Cautions
- Preparation for Installation
- Installation Instructions

Make sure to familiarize yourself with the **SAFETY SYMBOLS** shown on the next page. These symbols are used throughout this manual and relate to important safety information and issues affecting the end user or operator.

SAFETY SYMBOLS



Direct current (DC)



Alternating current (AC)



Both direct and alternating current



Three-phase alternating current



Protective Earth (ground) terminal



On (Supply)



Off (Supply)



Fuse



Caution: Always consult this manual when you see this warning symbol marking in order to familiarize yourself with the nature of the potential hazard and actions to be taken to avoid them.



Caution, risk of electric shock

2.4 Safety Notices

SAFETY SUMMARY

The following general safety precautions must be observed during all phases of operation, service, and repair of this instrument. Failure to comply with these precautions or with specific warnings elsewhere in this manual violates safety standards of design, manufacture, and intended use of the instrument. Pacific Power Source assumes no liability for the customer's failure to comply with these requirements.



CAUTION: CLASS 1 INSTRUMENT

This product is a Safety Class 1 instrument (provided with a protective earth terminal). The protective features of this product may be impaired if it is used in a manner not specified in the operation instructions.



AVERTISSEMENT: APPAREIL CLASSE 1

Cet produit est un appareil Classe 1 (avec terre de protection). Les dispositifs de sécurité de ce produit peuvent être altérés si le produit est utilisé d'une manière non spécifiée dans le manuel d'utilisation.



CAUTION: ENVIRONMENTAL CONDITIONS

This instrument is intended for indoor use in an installation category II, pollution degree 2 environments only. It is designed to operate at a maximum relative humidity of 80% for temperatures up to 40 °C and at altitudes of up to 2000 meters. Refer to the specifications tables for the ac mains voltage requirements and ambient operating temperature range.



AVERTISSEMENT: CONDITIONS ENVIRONNEMENTALES

Cet appareil est destiné à une utilisation intérieure dans une installation de catégorie II, degré de pollution 2. Il est conçu pour fonctionner sous humidité relative maximale de 80%, pour des températures allant jusqu'à 40°C et à des altitudes allant jusqu'à 2000 m. Se reporter aux tableaux de spécifications pour les exigences en terme de tension secteur et plage de température ambiante de fonctionnement.

**CAUTION: BEFORE APPLYING POWER**

Verify that the product AC input specifications noted on the model tag matches the available utility line voltage and frequency.

**ATTENTION: AVANT DE METTRE SOUS TENSION**

Vérifier que les spécifications de tension d'alimentation de l'équipement notées sur l'étiquette sont bien compatibles avec la tension et fréquence secteur disponibles.

**SAFETY NOTICE: GROUNDING**

This product is a Safety Class 1 instrument (provided with a protective earth terminal). To minimize shock hazard, the instrument chassis or cabinet must be connected to an electrical safety ground. The instrument must be connected to the AC power supply mains through a properly rated three phase power cable with protective earth (L1-L2-L3-E). Any interruption of the protective (grounding) conductor or disconnection of the protective earth terminal will cause a potential shock hazard that could result in personal injury.

This instrument is equipped with a line filter to reduce electromagnetic interference and must be properly grounded to minimize electric shock hazard. Operation at line voltages or frequencies in excess of those stated on the model type plate may cause leakage currents in excess of 5.0 mA peak.

**REGLE DE SECURITE: MISE A LA TERRE**

Ce produit est un équipement de Classe 1 (muni d'une borne de mise à la terre). Pour minimiser le risque de choc électrique, le châssis de l'appareil ou de l'armoire/rack doit impérativement être relié à une terre de sécurité électrique. L'appareil doit être branché sur le secteur d'alimentation électrique à courant alternatif par un câble d'alimentation triphasé approprié avec terre de protection (L1-L2-L3-PE). Toute interruption de la mise à la terre de protection ou de déconnexion de la borne de terre causera un risque de choc électrique qui pourrait entraîner des blessures.

Cet appareil est équipé d'un filtre secteur pour réduire les interférences électromagnétiques et doit être correctement mis à la terre afin de minimiser le risque de choc électrique. Le fonctionnement sous tensions et fréquences supérieures à celles indiquées sur l'étiquette peut provoquer des courants de fuite de plus de 5,0 mA peak.

**CAUTION: DO NOT OPERATE IN AN EXPLOSIVE ATMOSPHERE**

Do not operate the instrument in the presence of flammable gases or fumes.

**AVERTISSEMENT: NE PAS UTILISER SOUS ATMOSPHERE
EXPLOSIVE**

Ne pas faire fonctionner l'appareil en présence de gaz ou vapeurs inflammables.

**CAUTION**

The AC input connections must include a disconnect device (an external switch or circuit-breaker) as part of the installation. The disconnect device must be suitably located and easily reached and must be marked as the disconnecting device for the equipment. The disconnect device must disconnect all line conductors simultaneously.

An external overcurrent protection device must be provided (by, e.g., fuses or circuit breaker). The breaking capacity of the overcurrent protection device should be compatible with the current rating of the installation.

A minimum of basic insulation is required between mains-connected parts of opposite polarity on the supply side of the overcurrent protection device.

Overcurrent protection devices shall not be fitted in the protective conductor. Fuses or single pole circuit-breakers shall not be fitted in the neutral conductor of multi-phase equipment.

Installation should be in accordance with ANSI/NFPA 70, NEC.

After disconnecting grid power, ALWAYS wait at least 1 minute, then use a Digital Voltmeter (DMM) in VDC Mode to check for any residual DC voltage from each Line terminal to the Chassis ground stud to check for safe voltage levels (< 5 Vdc) before touching the unit or any terminal blocks or pins.

**AVERTISSEMENT**

Les connexions d'entrée AC doivent inclure un dispositif de déconnexion (un commutateur externe ou disjoncteur) dans le cadre de l'installation. Le dispositif de déconnexion doit être convenablement situé et facilement accessible et doit être marqué comme le dispositif de déconnexion de l'équipement. Le dispositif de déconnexion doit déconnecter tous les conducteurs de ligne simultanément.

Un dispositif de protection de surintensité externe doit être fourni (par exemple, par des fusibles ou coupe-circuit). Le pouvoir de coupure du dispositif de protection contre les surintensités doit être compatible avec le courant nominal de l'installation.



AVERTISSEMENT

Un minimum d'isolation de base est nécessaire entre les parties de réseau connecté de polarité opposée sur le côté d'alimentation du dispositif de protection contre les surintensités.

Les dispositifs de protection contre les surintensités ne doivent pas être installés dans le conducteur de protection. Fusibles ou simples disjoncteurs ne doivent pas être installés dans le conducteur neutre des équipements multi-phasés.

L'installation doit être conforme à la norme ANSI / NFPA 70, NEC.

Après avoir débranché l'alimentation du réseau, attendez TOUJOURS au moins 1 minute, puis utilisez un voltmètre numérique (DMM) en mode VDC pour vérifier toute tension CC résiduelle de chaque borne de ligne sur le plot de masse du châssis pour vérifier les niveaux de tension sécurisés (<5 Vcc) avant de toucher l'unité ou des borniers ou des broches.

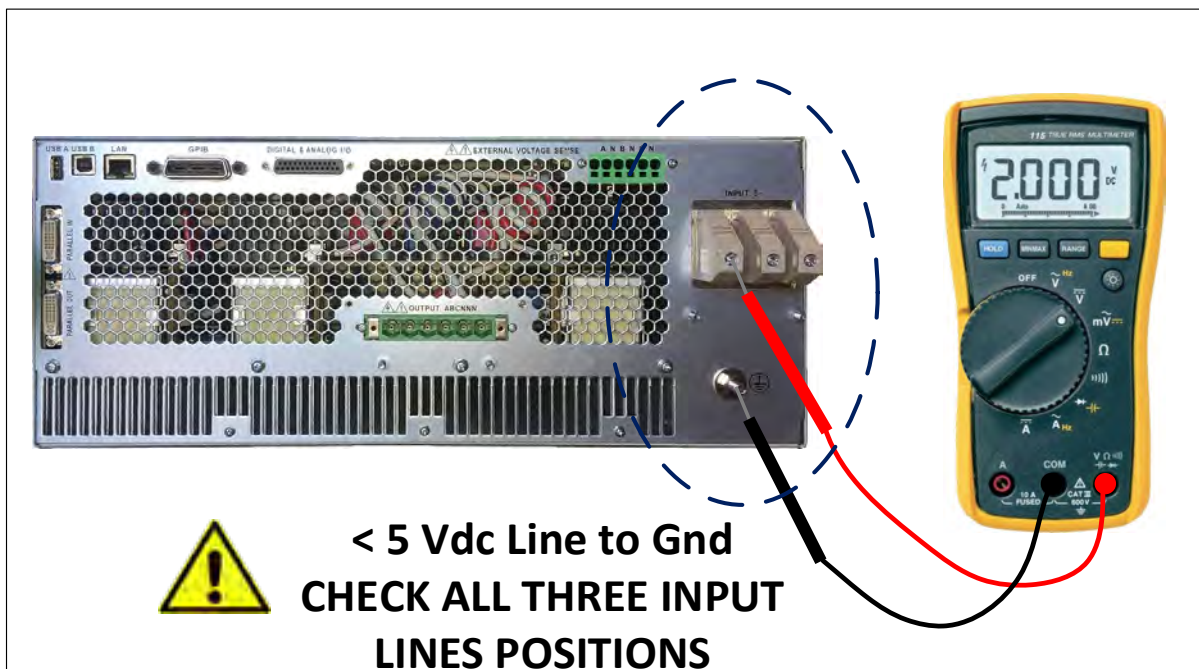

Figure 2-1: EMI AC Input Filter Residual Voltage Check after disconnecting AC Mains power



CAUTION: DO NOT SUBSTITUTE PARTS OR MODIFY INSTRUMENT

Because of the danger of introducing additional hazards, do not install substitute parts or perform any unauthorized modification to the instrument. Return the instrument to a Pacific Power Source Sales and Service Office for service and repair to ensure that safety features are maintained.

Instruments that appear damaged or defective should be made inoperative and secured against unintended operation until they can be repaired by qualified service personnel.

**AVERTISSEMENT: NE PAS REMPLACER DE PIÈCES ET DE COMPOSANTS
– NE PAS MODIFIER L'ÉQUIPEMENT**

En raison d'introduction de dangers supplémentaires, ne pas installer des pièces de rechange et ne pas effectuer de modification de l'équipement non autorisés. Retourner l'appareil à un bureau de ventes et services Pacific Power Source pour le service et la réparation afin d'assurer le maintien des caractéristiques de sécurité. Les appareils qui semblent endommagés ou défectueux doivent être rendus inopérants et protégés contre le fonctionnement involontaire jusqu'à ce qu'ils puissent être réparés par un personnel qualifié.

**CAUTION: INSTRUMENT LOCATION**

Do not position this instrument in such a way as to block easy access to any mains disconnect device or in any way that makes it difficult to operate the mains disconnect device.

**ATTENTION: EMPLACEMENT DE L'APPAREIL**

Ne pas placer cet appareil de manière à bloquer l'accès facile à tout débranchement du réseau électrique ou d'une façon qui rende difficile l'opération de débranchement du réseau électrique.

3 Product Overview

This chapter provides an overview of the PPS AFX Series® programmable power sources. It introduces the reader to general operating characteristics of these power supplies.

3.1 General Description

The Pacific Power Source (PPS) AFX Series® power source is designed to provide accurate, stable and clean AC or DC power to a unit under test. The PPS AFX Series® power supply can be operated from the front panel (manual mode) or using RS232, USB or LAN (Ethernet) remote control.

The performance of the AFX Series® power source models are detailed in section 4, “Technical Specifications”. Maximum voltage, current and power capability depends on the specific model. This manual covers standard AFX Series® models. Modified units are generally shipped with a manual addendum as a supplement to this manual. The manual addendum covers specific modifications from the standard model(s).

Model Number Decoder

All AFX Series models use a common model number scheme. The model decoder is shown in the diagram below.

Both “L” and “AG” versions of the AFX Series are covered by this user manual. The series designation letter is the first letter following the “-2” or “-4” input voltage designation on the type label.

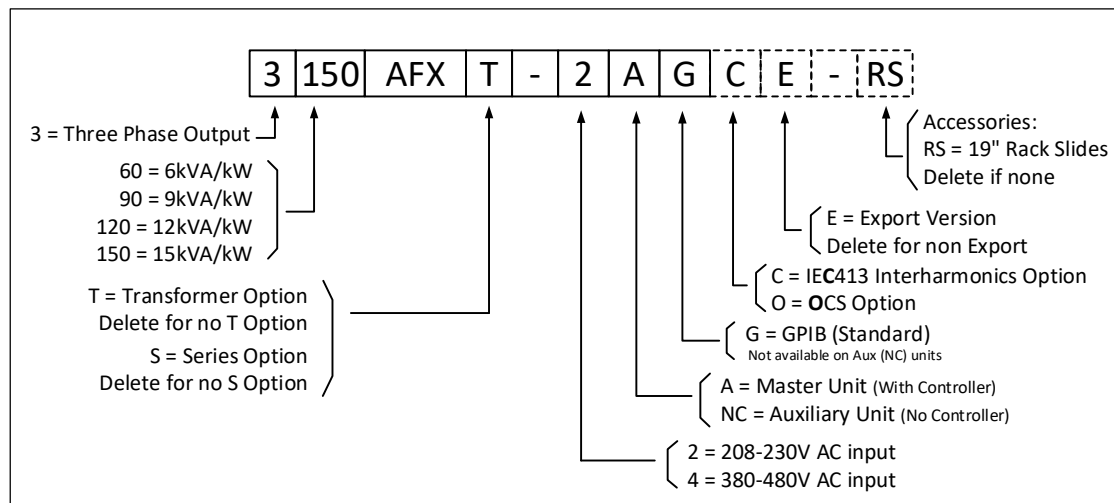

Figure 3-1: AFX Series Model Number Decoder

3.2 Product Features

The following key characteristics apply to all AFX Series® models;

- Fully programmable electronic power source with advanced controller functions.
- AC, DC and AC+DC output modes.
- Single, Split and Three phase output modes.
- Fully remote control of all settings and metering read back.
- Constant power mode auto-voltage range eliminates the need to switch between high and low voltage ranges.
- Over voltage, over current and overpower protection.
- External voltage sense.
- Programmable Output Impedance (R + L)
- Auxiliary I/O – Analog and Digital. (Only on “A” models)
- Optional additional High Voltage AC Range (Transformer Option)
- Optional Series Mode version (AFXS). **Must be specified at time of order.**
- Optional independent output modes (Option W). **Must be specified at time of order.**

3.3 Block Diagram

The block diagram of the fully digital power source is shown in Figure 3-2 below. It shows the key functional blocks for the three phase AFX models.

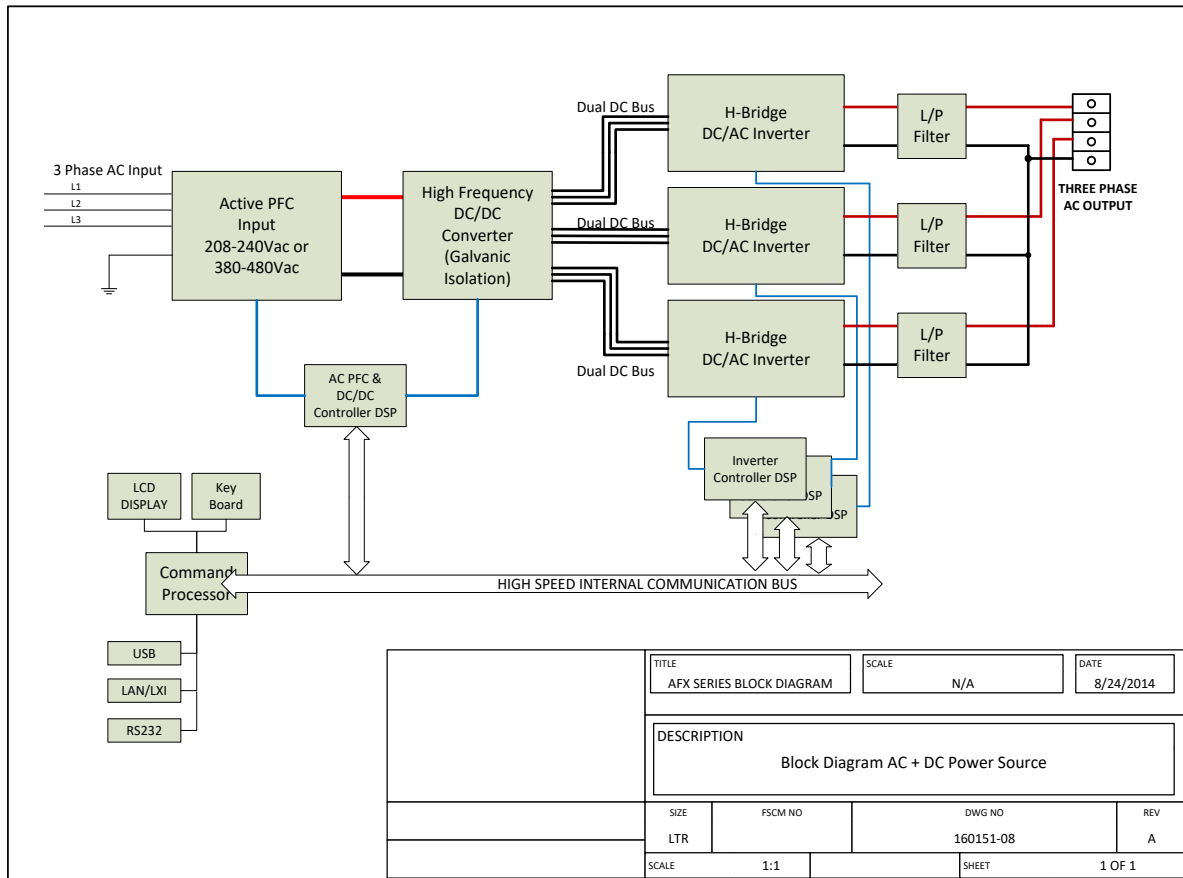

Figure 3-2: AFX Series® Basic Block Diagram

3.4 Controller Description

The AFX Series® power supplies use an advanced command processor that communicates with the internal power stages using several high speed communication buses and with the outside world through a variety of interfaces. One of these interfaces is the front panel keyboard and LCD display which supports manual operation of the AC power source.

The command processor handles all user inputs as well as any analog or digital input provided to the unit. All power stages are operated autonomously and take input from the main command processor. For larger power configurations consisting for multiple chassis, the master unit command processor communicates to all chassis that are connected on the master/auxiliary interconnect bus.

3.5 Measurement Read-back

The voltage, frequency and current limit settings of the AC power source can be set from the front panel or over any of the available digital remote control interfaces. During operation, the AC source output voltage, frequency, current and power can be read back for each of the available output phases.

3.6 Accessories Included (Ship Kit)

The following accessories are included with each AFX Series® AC power source. If one or more of these is missing upon incoming inspection of the product, please contact Pacific Power Source customer service. Note that AC input and AC output wiring, grid connection devices or external terminal blocks are NOT included with the power source or source cabinet systems.

Item	Quantity
Operation Manual in PDF Format	Available from PPS website
Mating Output Connector	1
Mating External Voltage Sense Connector	AFX L version :1 AFX AG Version: N/A
AC Input Terminal Safety Cover (metal)	1
Certificate of Conformance	1

Table 3-1: Included Accessories

3.7 Remote Control Interfaces

Following options can be ordered at time of original purchase. It is possible to have up to three different remote control interfaces per unit. Note that RS232 is standard so two more additional interfaces may be ordered.

Available Interfaces		Option Model No.
USB Interface	Standard	
RS-232 Interface	Standard	
LAN Interface	Standard	
AUX I/O	Standard on AFX-2AG/-4AG models	Not available on -2L/-4L Models
GPIB	Standard on AFX-2AG/-4AG models	Not available on -2L/-4L Models

Table 3-2: Remote Control Interface

4 Technical Specifications

Technical specifications shown here apply at an ambient temperature of 25° C ± 5° C.
Subject to change without notice.

4.1 Single Chassis Models

Three and Two (split) Phase Mode

MODEL	No. Outputs	Rated Power	Voltage Range		Curr./Output ₁	No. Chassis	
			AC	DC			
360AFX	3 Phase	6 kW	300 V rms	16.7 A rms	425 Vdc	16.7 Adc	1
390AFX	3 Phase	9 kW	300 V rms	25.0 A rms	425 Vdc	21.0 Adc	1
3120AFX	3 Phase	12 kW	300 V rms	33.3 A rms	425 Vdc	21.0 Adc	1
3150AFX	3 Phase	15 kW	300 V rms	41.7 A rms	425 Vdc	21.0 Adc	1

Single Phase Mode

MODEL	No. Outputs	Rated Power	Voltage Range		Curr./Output ¹	No. Chassis	
			AC	DC			
360AFX	1 Phase	6 kW	300 V rms	50.0 A rms	425 Vdc	50.0 Adc	1
390AFX	1 Phase	9 kW	300 V rms	75.0 A rms	425 Vdc	62.5 Adc	1
3120AFX	1 Phase	12 kW	300 V rms	100.0 A rms	425 Vdc	62.5 Adc	1
3150AFX	1 Phase	15 kW	300 V rms	125.0 A rms	425 Vdc	62.5 Adc	1

4.2 Multiple Chassis Models

Multi chassis model configurations consist of a single master unit and one or more slave units connected through a high-speed parallel bus. Each unit requires its own three-phase AC input and must be turned on at the front panel using its individual circuit breaker. This avoids massive inrush current at power up of the system as each unit can be turned on one at a time. Multi chassis systems are installed in a suitable 19" cabinet from the factory with a common AC input terminal block and a single phase or three phase common output terminal block.

Three and Two (split) Phase Mode

MODEL	No. Outputs	Rated Power	Voltage Range		Curr./Output ¹	No. Chassis	
			AC	DC			
3180AFX	3 Phase	18 kW	300 V rms	50.0 A rms	425 Vdc	41.7 Adc	2
3240AFX	3 Phase	24 kW	300 V rms	66.7 A rms	425 Vdc	41.7 Adc	2
3300AFX	3 Phase	30 kW	300 V rms	83.3 A rms	425 Vdc	41.7 Adc	2
3450AFX	3 Phase	45 kW	300 V rms	125.0 A rms	425 Vdc	62.5 Adc	3
3600AFX	3 Phase	60 kW	300 V rms	166.7 A rms	425 Vdc	83.3 Adc	4

Single Phase Mode

MODEL	No. Outputs	Rated Power	Voltage Range		Curr./Output ¹	No. Chassis	
			AC	DC			
3180AFX	1 Phase	18 kW	300 V rms	150 A rms	425 Vdc	125.0 Adc	2
3240AFX	1 Phase	24 kW	300 V rms	200 A rms	425 Vdc	125.0 Adc	2
3300AFX	1 Phase	30 kW	300 V rms	250 A rms	425 Vdc	125.0 Adc	2
3450AFX	1 Phase	45 kW	300 V rms	375 A rms	425 Vdc	189.0 Adc	3

¹ Note: Max. DC Current ratings shown require firmware revision 1.6.0 or higher.

MODEL	No.	Rated	Voltage Range	Current / Phs	Voltage Range	Curr./Output ¹	No.
3600AFX	1 Phase	60 kW	300 V rms	500 A rms	425 Vdc	250.0 Adc	4

4.3 AC Output Mode

AC OUTPUT	
Voltage	
AC Range	0 - 300 V L-N rms / 0 - 520V L-L rms, no VA or F restrictions
Extended Voltage Range ¹	0 - 333 V L-N rms / 0 - 576 V L-L rms, see Note 1
Transformer Option AC Range	Up to 600 V L-N rms / 0 - 1000 V L-L rms (Requires AFXT + Transformer)
Series Output Option AC Range	600 V L-N rms / 0 - 1000 V L-L rms (Requires AFXS + Auxiliry AFX-NC)
Programming Resolution	0.01 V
Accuracy	± 0.25% F.S.
Waveforms	Sine wave, Clipped, Square, Triangle, Saw tooth, Arbitrary Max. No. of waveforms: 200
DC Offset	< 20 mV
Harmonic Distortion ² (Vthd) (Full, Resistive Load)	< 100 Hz < 0.3% 100 Hz to 500Hz < 0.5% 500 to 1000 Hz < 1.0% > 1000 Hz < 1.5% See V THD Chart at bottom of next page
Output Noise (DC – 300 kHz)	< 150 mV rms
Load Regulation	± 0.02% (CSC Mode on)
Line Regulation	± 0.1% for 10% Line Change
External Voltage Sense	External Sense, max. voltage drop 5% FS.
Voltage Slew Rate	At least 1.0 V/us (AC Mode)
Isolation	550 Vrms
Frequency	
Range	15.00 – 1200.0 Hz
Extended Frequency Ranges ³	Ext. Low Freq. Range: 1.00 ~ 15.00 Hz, see Note 3 Ext. High Freq. Range: 1200 ~ 3000 Hz, see Note 3
Programming Resolution ⁴	0.01 Hz
Accuracy	± 0.01%
Current Limit	
Range ⁵	See model tables, Figure 4-6 and Figure 4-7. Values shown are supported for any period of time.
Current Overload	Available 30% Current overload for up to 2.0 seconds when enabled. See Figure 4-5.
Crest Factor	2.5:1 @ 41.67 to 6.3:1 @ 16.67 (104Apk / phase for 3150AFX)
Programming Resolution	0.01 A rms
Accuracy	± 0.5% F.S.
Modes	Constant Current Mode or Output Trip
Phase Angles (3 Phase Models)	
Phase Offsets ⁶	A = 0°, B = 240°, C = 120° (programmable)
Accuracy	± 0.35°
Phase Rotation in 3-Phs mode (default)	A, B, C = 0°, 120°, 240° (L1, L2, L3) Consistent with Pacific Power UPC Controller products. Phase rotation default phase rotation selectable using “reversed phase polarity” setting if desired.
Programmable Impedance (Real-Time Mode)	
Resistance (R)	Function of Phase Mode and No of units in parallel. See Table 4-1
Inductance (L)	
Programmable Impedance (RMS Mode)	
Resistance (R)	Function of Phase Mode and No of units in parallel. See Table 4-1
Inductance (L)	

AC OUTPUT											
Note 1:	Extended operation to 333V L-N / 576V L-L supported in Three and Split Phase mode up to 3.3kVA per phase for frequency range 45Hz ~ 800Hz. Some specifications exceptions apply. Requires firmware version 1.6.2 or higher. For AC voltage ranges higher than 333V L-N, see Sections 4.15 & 5.21, "T Option" on page 45 & 105.										
Note 2:	Refer to Figure 4-1, "Output Voltage distortion into full R Load as a function of Frequency" on next page.										
Note 3:	Extended operation from 1Hz to 15Hz supported at reduced maximum power on 12kVA and 15kVA models. Refer to Figure 4-2 on page 31. Instantaneous peak power (Vpk * Ipk) limited to 7kVA/phase below 15Hz. Requires firmware 2.0.0 or higher. Extended operation from 1200Hz to 3000Hz supported at reduced maximum voltage. Some specifications exceptions apply. Requires firmware version 1.6.2 or higher. Refer to Figure 4-3 on page 32 and Figure 4-4 on page 32.										
Note 4:	<p>FREQUENCY PROGRAM RESOLUTION FOR EXPORT MODELS (-4LE, -2LE, -4AGE, -2AGE): Per U.S.A. Bureau of Industry and Security, ECCN 3A225, frequency control is limited to no better than 0.2% at frequencies of 600 Hz. or more for unrestricted export products. To meet that requirement, frequency programming on all AFX-xxE models has three resolution ranges, which round the frequency to the nearest increment, as defined in the table below.</p> <p>Frequency Resolution for Export Models</p> <table border="1" style="margin-left: 40px;"> <thead> <tr> <th>Range</th> <th>Resolution</th> </tr> </thead> <tbody> <tr> <td>1.00 - 99.99 Hz</td> <td>0.01 Hz</td> </tr> <tr> <td>100-599.9 Hz</td> <td>0.1 Hz</td> </tr> <tr> <td>600 - 999 Hz</td> <td>2.0 Hz</td> </tr> <tr> <td>1000 - 3000 Hz</td> <td>5.0 Hz</td> </tr> </tbody> </table>	Range	Resolution	1.00 - 99.99 Hz	0.01 Hz	100-599.9 Hz	0.1 Hz	600 - 999 Hz	2.0 Hz	1000 - 3000 Hz	5.0 Hz
Range	Resolution										
1.00 - 99.99 Hz	0.01 Hz										
100-599.9 Hz	0.1 Hz										
600 - 999 Hz	2.0 Hz										
1000 - 3000 Hz	5.0 Hz										
Note 5:	Refer to AC Mode Voltage / Current rating charts Figure 4-6, Figure 4-10, Figure 4-7 and Figure 4-11 on following pages.										
Note 6:	Actual output phase angles may be slightly different from programmed values for highly unbalanced three phase load conditions, in particular at high frequency due to amplifier phase shift differences.										

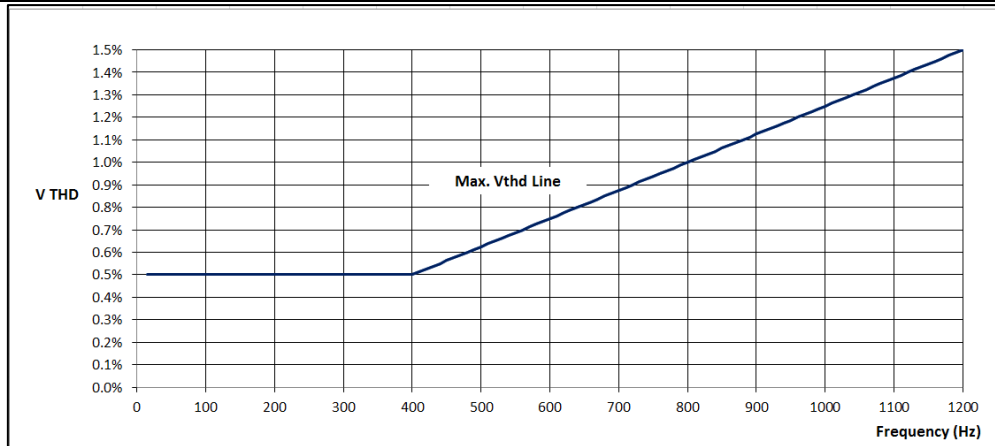

Figure 4-1: Output Voltage distortion into full R Load as a function of Frequency

4.3.1 Programmable Output Impedance Ranges by Phase Mode

The programmable range for output impedance varies based on model, phase mode setting. The table below summarizes the available ranges as function of these. Ranges are the same for Real-Time Mode and RMS Mode.

Note: For units with T option, impedance is multiplied by the square of the transformer ratio. Thus, for a TR of 2:1, the impedance range is multiplied by 4.

Models	Phase Mode	± Limits	0 - Max Limits
		R +/- Ohms	L + mH
360AFX, 390AFX, 3120AFX, 3150AFX	Three Phase	-10.00 ~ + 10.00	0 ~ 2.00
	Split Phase	-20.00 ~ + 20.00	0 ~ 4.00
	Single Phase	-10.00 ~ + 10.00	0 ~ 2.00

Table 4-1: Programmable Impedance Ranges by Phase mode

4.3.2 Programmable Impedance operation

Considerations when using Programmable Impedance functions.

In order to maximize the setting range for prog-Z, the AC Source controller gradually reduces the bandwidth of the feedback loop. This means that higher impedances (resistance and/or inductance) are slower to react.

At frequency settings of 50~60Hz, this works well in over the entire range. At higher frequencies the impedance accuracy will decrease, especially the inductive part (L).

Also, setting a high resistance (>1ohm) R impedance when the AC source is driving a highly capacitive load can result in instability.

The user should verify the prog-Z stability with the load before using it. ***Tight protection settings (peak and RMS current) are recommended to protect the power source and the load in case the system oscillates.***

Also, when using a negative impedance setting, the AC source can easily become unstable, depending on the load impedance, because negative impedance implies positive feedback which has a higher likelihood of causing instability.

4.3.3 Extended Frequency Ranges – Supplemental specs

Extended frequency range operation is supported for applications that require less than 15 Hz or more than 1200Hz fundamental frequency output. With the extended frequency disabled, the regular AFX allows to increase the frequency user limit up to 3000 Hz (default is 1200 Hz) and consequently the frequency setpoint.

However, as the frequency increase above 1200Hz, the ac voltage setpoint, current limit, power limit and KVA limit are derated with the following formulas:

$$v_ac_max = 300 * 1200 / frequency$$

$$current_limit_max = 41.67 * parallel_inverters * 1200 / frequency$$

$$\text{power_limit_max} = 5 * \text{parallel_inverters} * 1200 / \text{frequency}$$

$$\text{kva_limit_max} = 5 * \text{parallel_inverters} * 1200 / \text{frequency}$$

If output form is three phase then parallel_inverters = parallel_units

If output form is single phase then parallel_inverters = 3 * parallel_units

For example, a standalone 3150AFX in three phase mode at 3000 Hz allows up to 120 Vrms, 16.67 Arms, 2 kW and 2 kVA.

This derating is to protect the power stage output capacitor, the higher the frequency the higher the current on the capacitor.

Note that with the extended frequency mode enabled, the power source only derates the current limit not the Vac setpoint. This mode is useful for short periods of time or transients, if the load's AC power is too high for too much time, then it will end up tripping a fault.

Charts below show graphical representation of extended frequency operation.

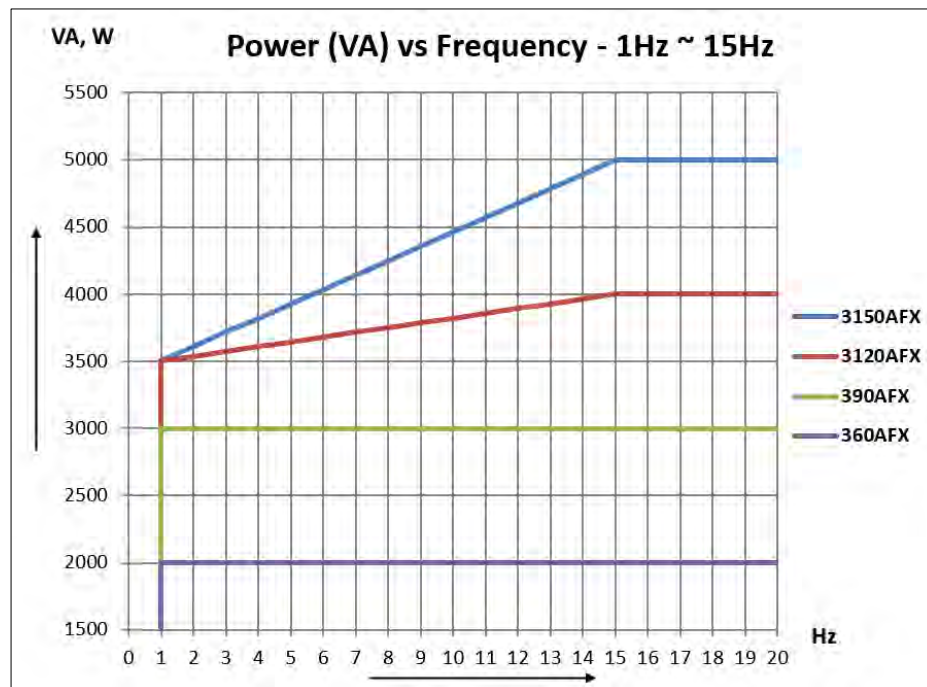

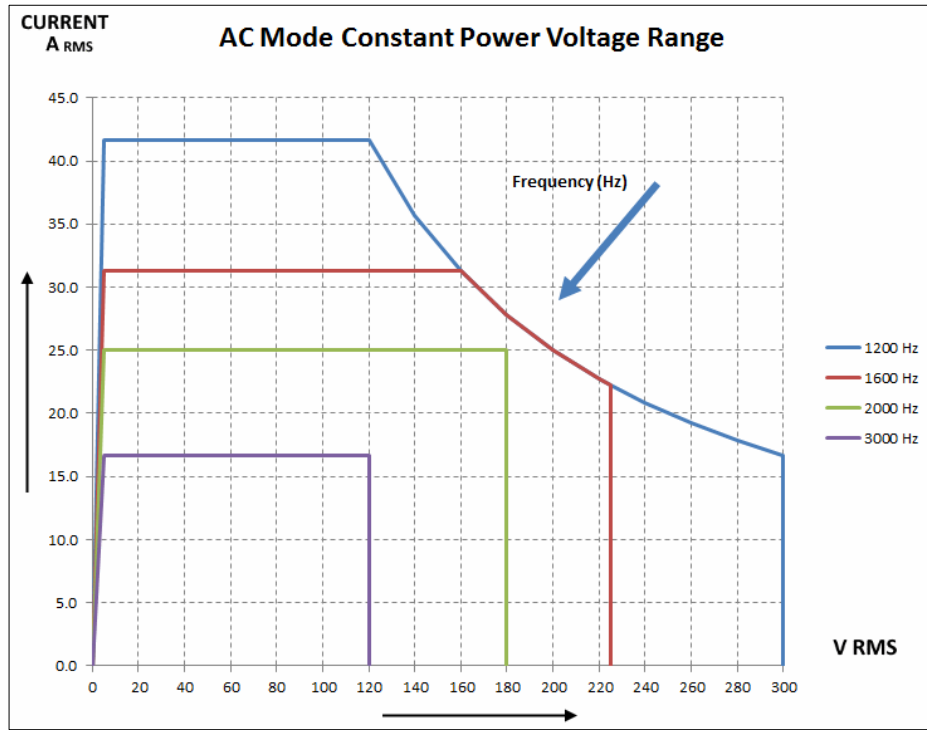

Figure 4-3: 1200Hz ~ 3000Hz Freq. Range Voltage vs. Current- 3150AFX in 3 Phs Mode

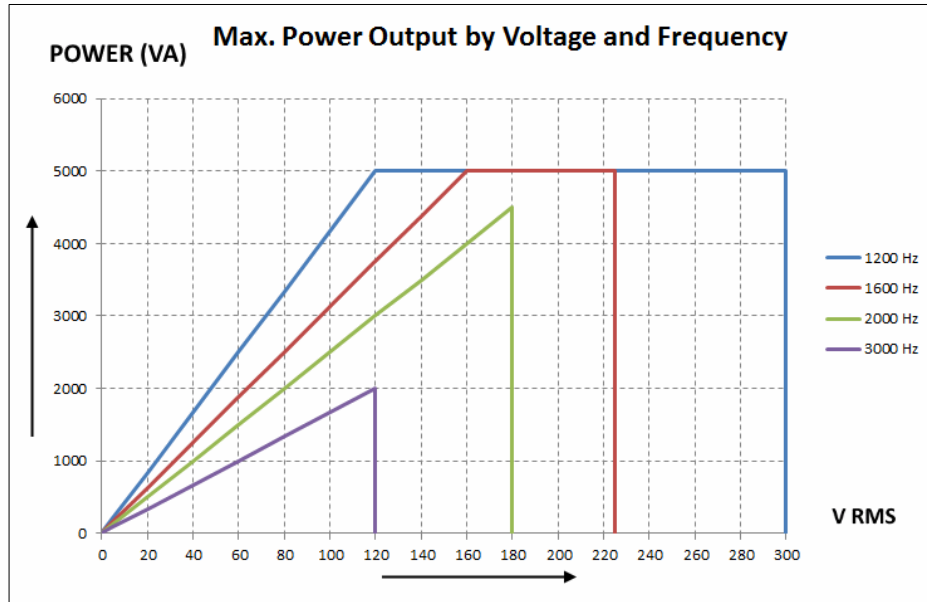
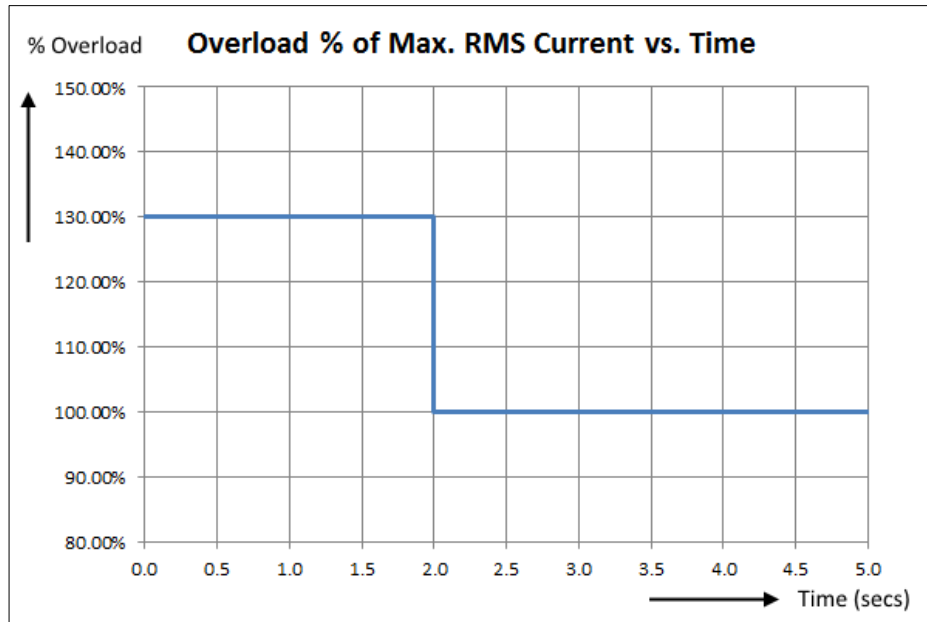

Figure 4-4: 1200Hz ~ 3000Hz Extended Freq. Range Power - 3150AFX in 3 Phs Mode

4.3.4 Temporary Current Overload



4.3.5 AC Voltage and Current Output Charts

AC VOLTAGE RANGES

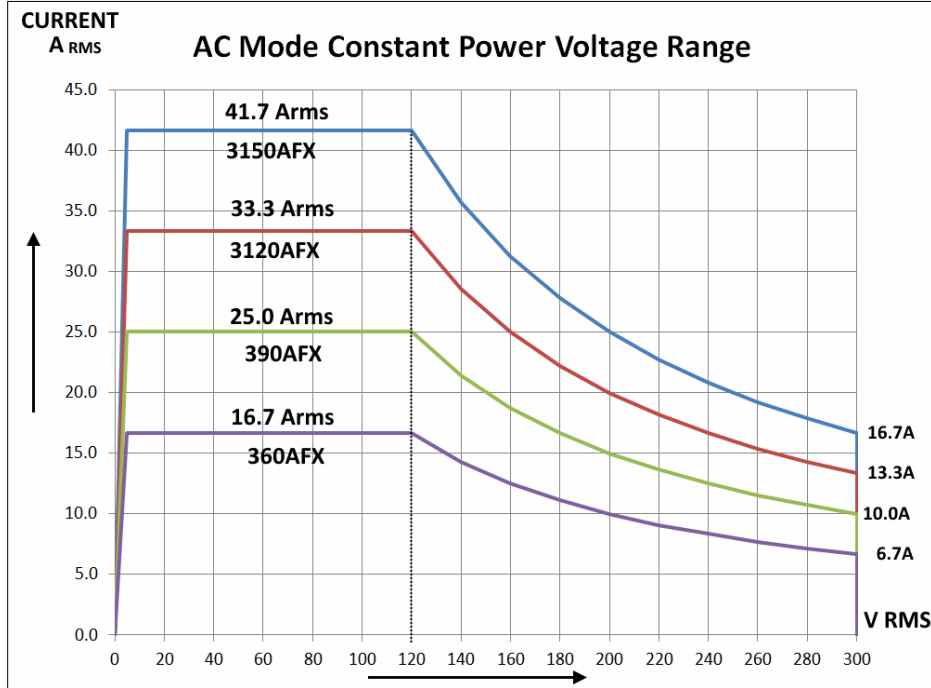

Figure 4-6: AC Mode Voltage/Current range, AFX Models - 3 or 2-phase mode.

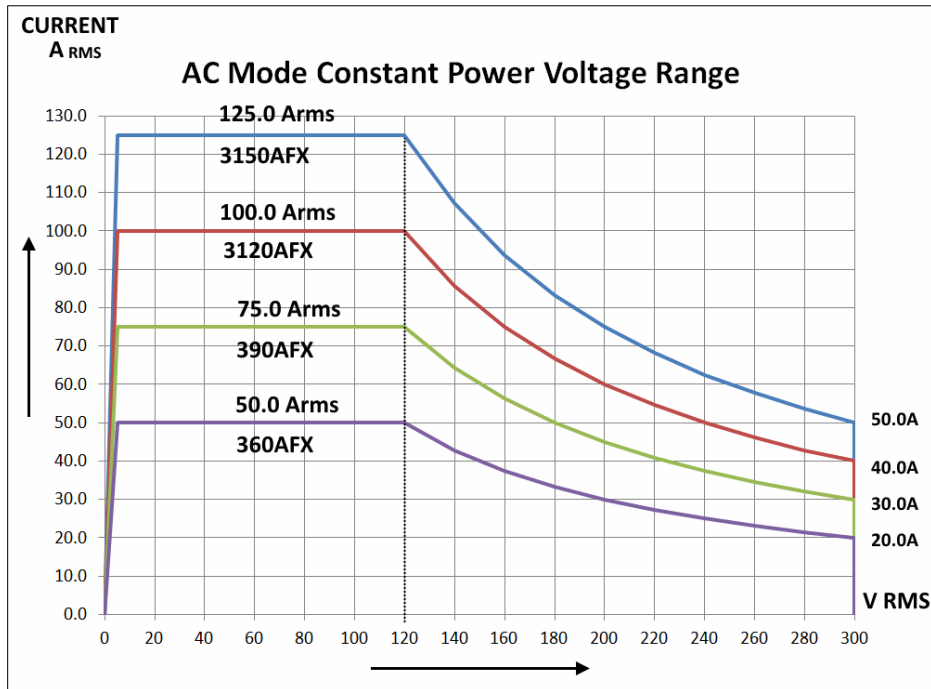

Figure 4-7: AC Mode Voltage/Current range, AFX Models – 1 phase mode.

4.3.6 Extended AC Voltage Ranges – Supplemental specs

The AFX provides three extended voltage ranges, 0 through 2. The maximum programmable Vrms AC limits for each of these extended ranges are:

- Range 0 312V_{LN}
- Range 1 320 V_{LN}
- Range 2 333 V_{LN}

Range 0 is activated by setting the AC voltage user limit to a value between 300 and 312. More details on extended range 0 are provided in section 6.4.13, page 131.

Range 1 and 2 must be enabled using a bus command before they can be activated in a similar way. Refer to

Note: For voltage limits higher than 312V L-N, this mode must be enabled first. See “[SOURCE:]VOLTage:EXTend” command in section 8.7.2 on page 287.

The following specification adjustments apply for each extended range mode.

Range 0: up to 312V

- Standard THD specs apply only from 45-100Hz
- Only supported in three phase mode
- Maximum output power is 3kW per phase

Range 1: up to 320V

- Max. current limited to 35Arms/phase
- Limits maximum frequency set point to 800Hz
- Does not guarantee THD specification but designed to have THD < 1.0% at Pout<9kW

Range 2: up to 333V

- Max. current limited to 35Arms/phase
- Limits maximum frequency set point to 800Hz
- Does not guarantee THD. Control loop may saturate at V > 320, giving a THD of 2-3% at 333V/9kW

These power and current restrictions are reflected in the charts below for reference.

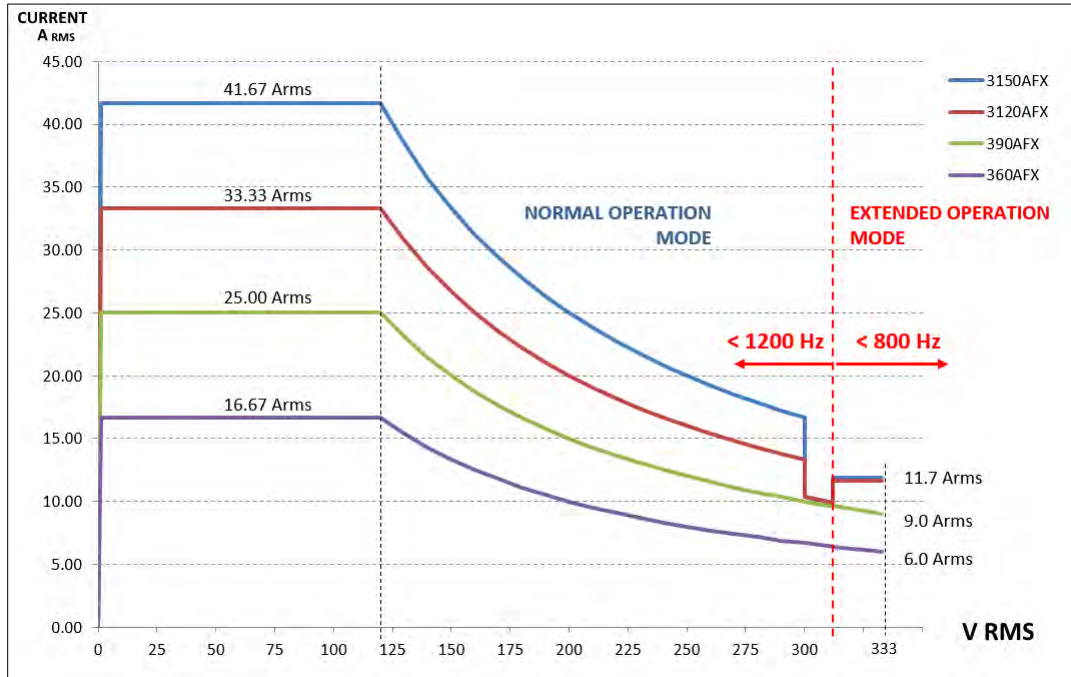

Figure 4-8: Extended AC Voltage/Current Range, AFX Models – 3 or 2 phase mode

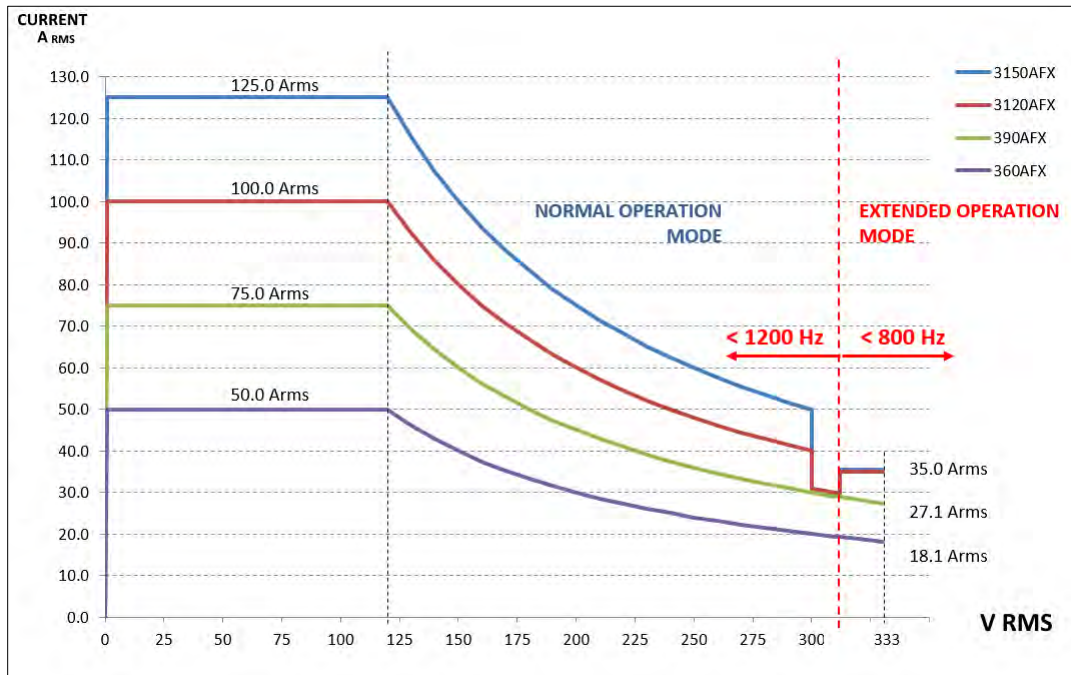

Figure 4-9: Extended AC Voltage/Current Range, AFX Models – 1 phase mode

4.4 DC Output Mode

DC OUTPUT	
Voltage	
Range	0 – 425 Vdc Refer to Figure 4-10 and Figure 4-11 for Voltage vs Current Constant Power Mode profile for 3 phase and 1 phase modes
Programming Resolution	0.01 V
Accuracy	± 0.25% F.S.
Noise & Ripple	< 150 mV rms
Load Regulation	± 0.02%
Line Regulation	± 0.1% for 10% Line Change
External Voltage Sense	External Sense, max. voltage drop 5% FS.
Voltage Slew Rate	At least 3.0 V/us (DC Mode)
Isolation	550 Vdc
Current Limit	
Range	See model tables, Figure 4-10 and Figure 4-11
Programming Resolution	0.01 Adc
Accuracy	± 0.5 Adc
Modes	Constant Current Mode or Output Trip

4.4.1 DC Voltage and Current Output Charts

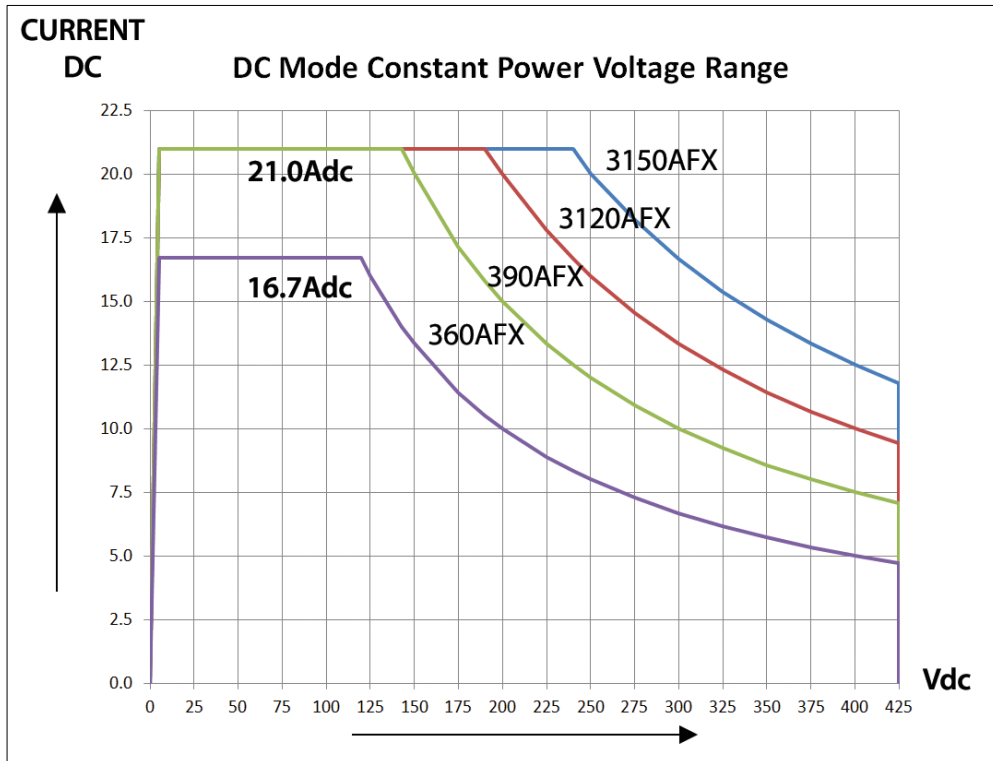

Figure 4-10: DC Mode Voltage/Current range, AFX Models- 3 or 2 phase mode.

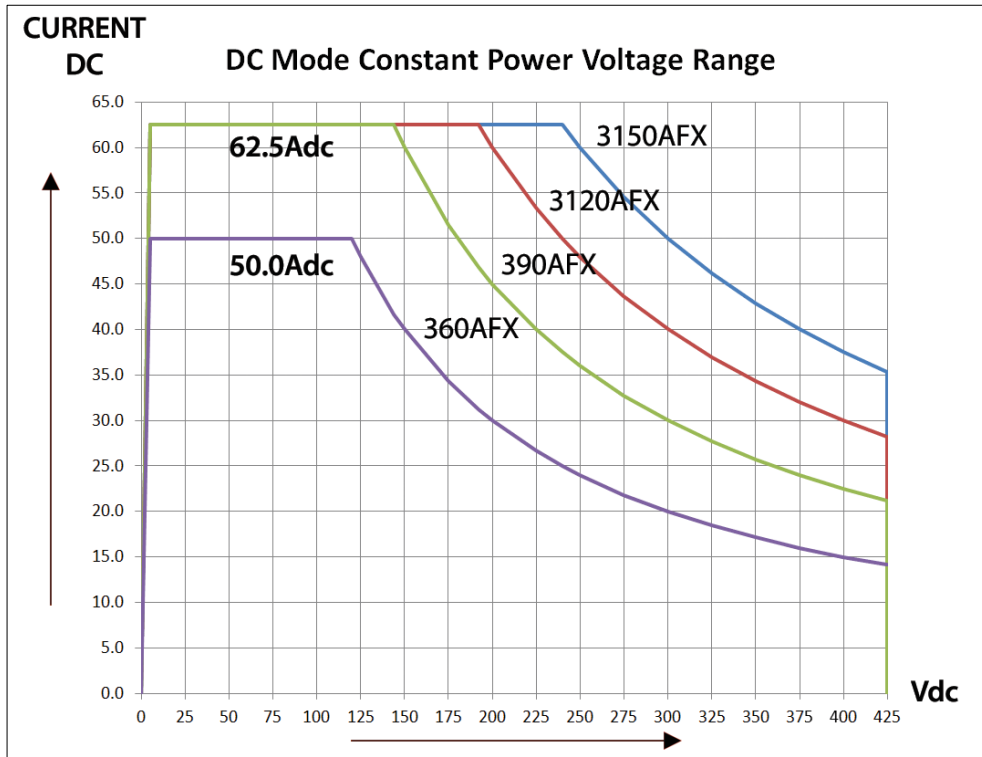

Figure 4-11: DC Mode Voltage/Current range, AFX Models - 1 phase mode.

4.5 Protection Modes

PROTECTION	
Protection Modes	Over Current fold-back or trip
	Progr. Peak Current Limit
	Power fold-back or trip
	Apparent Power fold-back or trip
	Over Voltage trip
	Over Temperature
OVP Range	0 - 105% Vmax
AC Input Voltage	Over and Under Voltage

4.6 Metering

MEASUREMENTS		
Voltage AC ⁽¹⁾		
Range	L-N: 0 – 350 V rms; L-L: 0 – 600 V rms	
Resolution	FP: 0.01 V / Bus: 0.001 V	
Accuracy	± 0.25% F.S.	
Frequency (AC Mode Only)		
Range	15 – 1200Hz	
Resolution	0.01 Hz	
Accuracy	± 0.1% Reading	
Current AC ⁽²⁾		
Range	See model table in section 4.1 or 4.2	
Resolution	FP: 0.01 A / Bus: 0.001 A	
Accuracy	± 0.5% F.S.	
Peak Current		
Range	4 x RMS current	
Resolution	FP: 0.01 A / Bus: 0.001 A	
Accuracy	± 1.5% F.S.	
Crest Factor		
Range	1.00 – 5.00	
Resolution	FP: 0.01 / Bus: 0.001	
Accuracy	± 2.0% F.S.	
True Power ^(2,)		
Range	See model table in section 4.1 or 4.2	
Resolution	FP: 1 W / Bus: 0.1 W	
Accuracy	± 1.5% F.S.	
Apparent Power ⁽²⁾		
Range	See model table in section 4.1 or 4.2	
Resolution	FP: 1 VA / Bus: 0.1 VA	
Accuracy	± 1.5% F.S.	
Power Factor ⁽³⁾		
Range	0.00 – 1.00	
Resolution	FP: 0.01 / Bus: 0.001	
Voltage DC		
Range	0- 440 Vdc	
Resolution	FP: 0.01 V / Bus: 0.001 V	
Accuracy	± 0.25% F.S.	
Current DC		
Range	See model table in section 4.1 or 4.2	
Resolution	FP: 0.01 A / Bus: 0.001 A	
Accuracy	± 0.5% F.S.	

Note 1: AC Voltage measurement accuracy shown for Line to Neutral measurements. Line to Line voltage measurements are calculated based on VLN and phase angles and are < 0.5% F.S. and valid only for sinusoidal voltage waveforms with low levels of distortion and under balanced three phase load conditions.

Note 2: Measurement Accuracies for Current and Power apply for load currents of 2.0 A or more.

Note 3: For Power level above 100 W

4.7 Other Measurements

Measurements																																						
Waveform Capture																																						
Time Domain	1024 samples/period																																					
Parameters	$V_{LN-A}, V_{LN-B}, V_{LN-C}, V_{LLAB}, V_{LLAC}, V_{LLBC}, IA, IB, IC$																																					
Samples/cycle	1024 (512 in UPC Compatibility mode)																																					
Record Length	1 Period of fundamental Frequency																																					
Bandwidth	27.45 kHz																																					
Harmonics Measurements																																						
Parameters	$V_{LN-A}, V_{LN-B}, V_{LN-C}, V_{LLAB}, V_{LLAC}, V_{LLBC}, IA, IB, IC$																																					
Harmonics Range	H1 ~ H50																																					
Accuracy – Amplitude	± 1.0 % of RMS Reading																																					
Phase Angle Range	0 ~ 359.9																																					
Accuracy - Phase Angle	< 20 μ sec																																					
Bandwidth	FW < 2.2.51: 13,600 Hz Max Harmonic measured @ Freq: <table border="1"> <thead> <tr> <th>Fset</th> <th>Max Harm</th> <th>Max. Freq.</th> </tr> </thead> <tbody> <tr> <td>15</td> <td>50</td> <td>750 Hz</td> </tr> <tr> <td>50</td> <td>50</td> <td>2500 Hz</td> </tr> <tr> <td>400</td> <td>34</td> <td>13600 Hz</td> </tr> <tr> <td>800</td> <td>17</td> <td>13600 Hz</td> </tr> <tr> <td>1200</td> <td>11</td> <td>13200 Hz</td> </tr> </tbody> </table>	Fset	Max Harm	Max. Freq.	15	50	750 Hz	50	50	2500 Hz	400	34	13600 Hz	800	17	13600 Hz	1200	11	13200 Hz	FW 2.2.51 and higher: 27,200 Hz Max Harmonic measured @ Freq: <table border="1"> <thead> <tr> <th>Fset</th> <th>Max Harm</th> <th>Max. Freq.</th> </tr> </thead> <tbody> <tr> <td>15</td> <td>50</td> <td>750 Hz</td> </tr> <tr> <td>50</td> <td>50</td> <td>2500 Hz</td> </tr> <tr> <td>400</td> <td>50</td> <td>20000 Hz</td> </tr> <tr> <td>800</td> <td>34</td> <td>27200 Hz</td> </tr> <tr> <td>1200</td> <td>22</td> <td>26400 Hz</td> </tr> </tbody> </table>	Fset	Max Harm	Max. Freq.	15	50	750 Hz	50	50	2500 Hz	400	50	20000 Hz	800	34	27200 Hz	1200	22	26400 Hz
Fset	Max Harm	Max. Freq.																																				
15	50	750 Hz																																				
50	50	2500 Hz																																				
400	34	13600 Hz																																				
800	17	13600 Hz																																				
1200	11	13200 Hz																																				
Fset	Max Harm	Max. Freq.																																				
15	50	750 Hz																																				
50	50	2500 Hz																																				
400	50	20000 Hz																																				
800	34	27200 Hz																																				
1200	22	26400 Hz																																				
Display Modes	Table format, Graph Format																																					

4.8 Transients

Transients	
Programming	
No. of Entries	200 Steps, 400 Segments
Parameters	Voltage, Frequency, Phase B & C, Ramp Time, Dwell Time
Dwell Time Range	0.0 – 10,000,000 msec
Ramp Time Range	0.2 – 10,000,000 msec
Time Resolution	0.1 msec
Edit Modes	Add at End, Insert Before, Delete
Execution	
Run Control	Run from Step # to Step # Run, Step, Restart, Stop
Program Storage	
Non-Volatile	100, Programs + Transients

4.9 AC Input

AC INPUT	6 kVA	9 kVA	12 kVA	15kVA
Frequency Range				
AC Input Frequency	47 - 63 Hz			
Connection	4 Wire, (L1, L2, L3 and PE)			
-208 Input Version (-2)				
Input Voltage Range	208 Vac – 240 Vac ± 10%			
Nominal Phase Current @ 208V 3 ϕ	23 A rms	33 A rms	43 A rms	51 A rms
Max. Rated Phase Current, 3 ϕ	25 A rms	37 A rms	48 A rms	55 A rms
Peak Inrush Current ²	< 1.5 x I _{rms}			
Input Power Factor	> 0.9			
Efficiency	> 85 %			
Internal Line Fuses -2 NOT USER SERVICEABLE				
Type	FUSE, SEMICONDUCTOR,22X58MM			
Rating	80A,600VAC			
-400 / -480 Input Version (-4)				
Input Voltage Range	380 Vac – 480 Vac ± 10%			
Nominal Phase Current @ 380V 3 ϕ	13 A rms	18 A rms	24 A rms	27 A rms
Max. Rated Phase Current	15 A rms	20 A rms	27 A rms	30 A rms
Nominal Phase Current @ 480V 3 ϕ	11 A rms	14 A rms	20 A rms	23 A rms
Max. Rated Phase Current	13 A rms	16 A rms	23 A rms	28 A rms
Peak Inrush Current ³	< 1.5 x I _{rms}			
Input Power Factor	> 0.9			
Efficiency	> 85 %			
Internal Line Fuses -4 NOT USER SERVICEABLE				
Type	FUSE, SEMICONDUCTOR,22X58MM			
Rating	63A,600VAC			

NOTE: For models consisting of multiple chassis, power input ratings apply to each chassis.

4.10 Dimensions & Weight

DIMENSIONS & WEIGHT	6 kVA	9 kVA	12 kVA	15 kVA
Dimensions				
Height	7.0" / 178 mm / 4U			
Width	17.0" / 432 mm – w/o rack handles 19.0" / 483 mm - with attached rack handles			
Depth	25.0" / 635 mm			
Weight				
Net	111.2lbs. / 50.4 kg			
Shipping	130 lbs. / 59 kg			

NOTE: For models consisting of multiple chassis, multiply weight and height by the number of chassis.

See dimension drawing. 3D Step Models Available on request.

² For nominal line input voltage

³ For nominal line input voltage

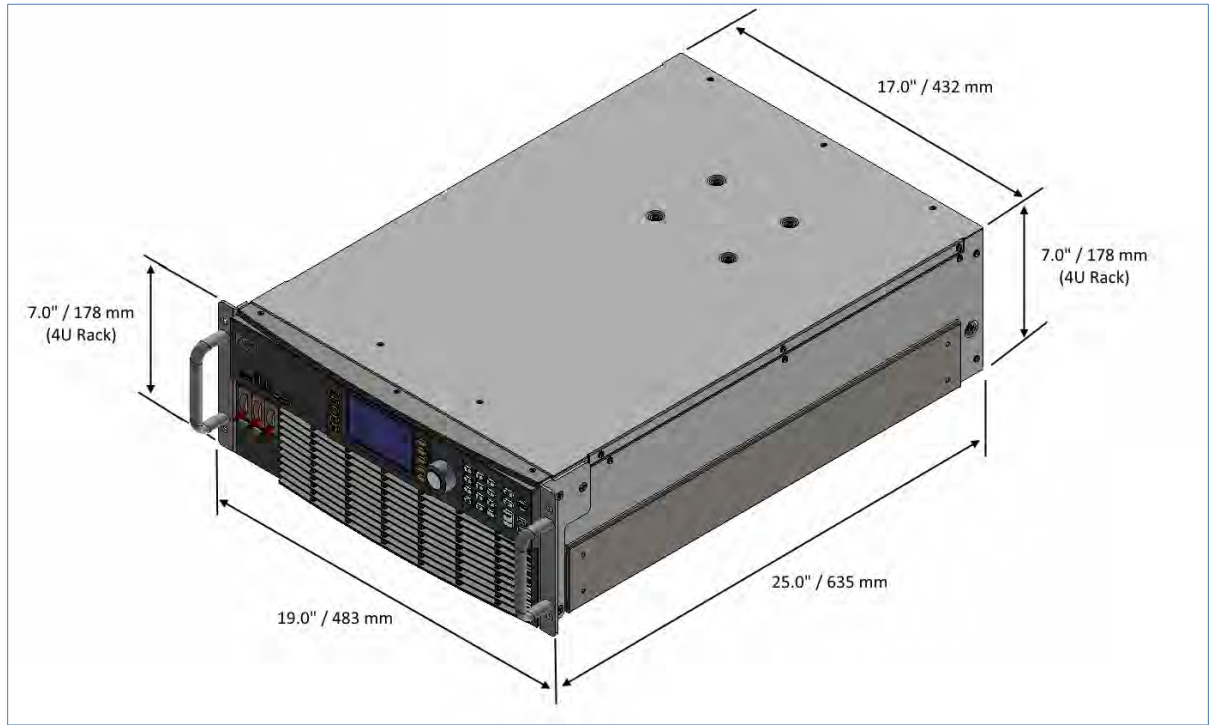

Figure 4-12: Dimension Drawing AFX Series® 15KW Model

4.11 Environmental

ENVIRONMENTAL	
Cooling	Fan Cooled
Audible Noise (at 1 meter)	Standby: 46 dBA Full power: 85 dBA typical
Operating Temperature	0 to 40 °C / 32 to 104 °F
Storage Temperature	-20 to 70 °C / -4 to 158 °F
Humidity	< 80%, non-condensing for temperatures up to 40° C
Altitude (max.)	2000 m / 6560 feet
Equipment ingress protection rating per IEC 60529	IP20

4.12 Safety & Regulatory

SAFETY & REGULATORY	
Safety Standard	EN 61010-1:2010 (Edition 3)
EMC Emissions	EN 55011:2009+A1:2010
EMC Immunity	EN 6100-4-2, -3, -4, -5, -6, -8, -11
Product Category	EN61326-1:2010 (Measurement, Laboratory and Control Equipment)
Approvals	CE Mark, NTRL Nemko US/Canada

4.13 Digital Interfaces

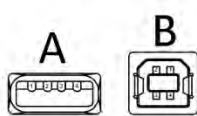
USB	
USB Standard	USB 2
USB Class	
Front Panel	Type A USB Host (2)
Connector	Type A, standard
Rear Panel	Type A USB Host (1) Type B USB Device (1)
Connector Types	

RS232	
Baud rate:	9600, 14400, 19200, 38400, 57600, 62500, 115200
Parity:	O = Odd = uneven parity E = Even = even parity N = None = no parity bit
Number of data bits:	7 or 8
Number of stop bits:	1 or 2
Handshake:	Xon/Xoff
Signal Levels:	
Inputs (RxD)	Maximum input voltage: ± 25 V Input Impedance: 5 k Ω typical Switching thresholds: $V_H < -3$ V, $V_L > +3$ V
Outputs (TxD)	Output voltage (at $R_{LOAD} > 3$ k Ω): min ± 5 V, typical ± 5.4 V Output Impedance: < 300 Ω min., 10 M Ω typical in power off state Short circuit current: Typ. ± 35 mA typical

Ethernet (L)	
Protocol	Ethernet TCP/IP, 100Mb/1000Mb
Connector	RJ45
Webserver	Built-in
LXI Compliance	Core, version 1.4

GPIB	
IEEE Standard	IEEE488.1, IEEE488.2 (2003 incl., NI HS488) IEC 60488-1, IEC 60488-2 (2004)
IEEE Functions Supported	SH1, AH1, T6, L3, SR1, RL1, DC1, DT1
Connector	Amphenol 24 pin, Micro ribbon connector. Rear Panel Set screws: M3.5x0.6 metric threads.
Available on Models	3xxxAFX-2AG or 3xxxAFX-4AG models only

Remote Inhibit	
Operation	Contact closure enables Output On/Off control Open circuit disables On/Off control
Modes	Disabled, Live or Latching (Configurable)
Connector	For 3xx0-2L / -4L models: DB9, Rear Panel For 3xx0AFX-2AG / -4AG models: DB25, Rear Panel (See Auxiliary I/O)

4.14 Auxiliary I/O

The Auxiliary I/O functions are only available on 3xx0AFX-2AG and 3xx0AFX-4AG version power source models.

The following technical specifications apply to the Auxiliary I/O functions.

AUX I/O SIGNAL SPECIFICATIONS	
Digital Inputs	
Input Signals	Remote Inhibit, External Trigger Input, Phase Sync, User Inputs (3)
Voltage Levels	Logic low: $V_{in} < 0.4\text{ V}$ Logic High: $V_{in} > 2.0\text{ V}$
Input Impedance	10 k Ω
Absolute max. voltage	12V
Digital Outputs	
Output Signals	<p><i>Open Collector (0.5A max. protection):</i> FORM Relay Control, Transformer Relay Control</p> <p>Note: DO1 and DO2 are TTL outputs with 5.2V output and 200Ω output impedance. Into a 5kΩ load, the output voltage is ~5V.</p> <p>Note: DO3 and DO4 are open-drain outputs with internal pull-up of 1k to 5.5V with a diode protection. At no load, these outputs will measure 5.5V. With a 5kΩ impedance, these outputs will measure ~4.6V.</p> <p><i>TTL Level:</i> Relay State/Function Strobe / Trigger Out Phase Reference (sync output) User programmable outputs (2)</p>
Voltage Levels @ 0.4 mA	Logic low: $V_{in} < 0.4\text{ V}$ Logic High: $V_{in} > 4.6\text{ V}$
Output impedance	200 Ω
Analog Inputs	
Signals	Analog Inputs (4)
Voltage Range	-10V – 10V
Accuracy	$\pm 0.1\%$ F.S.
Sampling Rate	10 Hz or 10 times/sec
Open Circuit Level	2 ~ 3 % of F.S. if analog input is left floating (no connection)
Input Impedance	5 k Ω
Absolute max. voltage	12V
Analog Outputs	
Signals	Analog Outputs (4)
Voltage Range	0V – 10V
Accuracy	$\pm 0.1\%$ F.S. (with 5 k Ω load or higher)
Update Rate	10 Hz or 10 times/sec
Output Impedance	5 k Ω
Power	
Output	12.0 Vdc
Accuracy	$\pm 0.1\%$ Vdc
Max. Current	0.5 Adc
RS232	
Signals	Tx, Rx
Handshake	Xon/ Xoff
Baud rates	9600 – 460800 bps

Auxiliary I/O Signal Protection Information and Recommendations

- All the signals on the auxiliary I/O DB25 port have double insulation with respect to high voltage. They are safe to touch (SELV) and safe to connect to any other equipment.
- These signals are referenced to earth, so any data acquisition card or equipment used to control the power source should be referenced to the same earth as the power source. For the power source unit, earth is its chassis.
- If the controlling computer connected to the power source is connected to an earth with different potential - this can happen when using different outlets or AC utility circuits - , that voltage difference can damage low-signal circuits.
- Analog outputs cannot be negative and cannot be higher than 5V. Any DAQ card or instrument used to monitor/read these outputs must have a sufficient input voltage range.
- In general, it is recommended to limit signal input voltages with series resistors and clamping diodes in case the “source” can generate a voltage higher than the maximum allowed by the analog inputs of the power source. See relevant specification on the previous page.

4.15 Transformer Output Voltage Range (T Option)

If more than 332Vac L-N is required in three-phase mode, the 400V Transformer option may be added to an AFX power source. This option provides an additional 400Vac L-N AC only voltage range. The standard 300Vac L-N voltage range as well as the DC mode and AC+DC modes remain available as the output transformer for this option are bypassed when not in use.



Figure 4-13: Rack Mount Chassis for 6kVA to 15kVA Transformer Option

4.15.1 Available T Option Rating Versions

The Transformer option is available in several power levels to match the AFX source configuration. The following transformer option ratings are available. Note that AFX models used with a Transformer option are designated by an “AFXT” series designation.

AFXT Models	Transformer Rating
360AFXT-2AG/-4AG	Rack Mount 19" Chassis, 4U (7") height. Rated for 15kVA max, 0 -400Vac _{LN} / 0 – 692Vac _{LL}
390AFXT-2AG/-4AG	
3120AFXT-2AG/-4AG	
3150AFXT-2AG/-4AG	
3180AFXT-2AG/-4AG	Transformers are installed in 19" Cabinet Systems along with AFX power sources Rated to 30kVA max, 0 -400Vac _{LN} / 0 – 692Vac _{LL}
3240AFXT-2AG/-4AG	
3300AFXT-2AG/-4AG	
3450AFXT-2AG/-4AG	Transformers are installed in 19" Cabinet Systems along with AFX power sources Rated to 45kVA max, 0 -400Vac _{LN} / 0 – 692Vac _{LL}
3600AFXT-2AG/-4AG	Transformers are installed in 19" Cabinet Systems along with AFX power sources Rated to 60kVA max, 0 -400Vac _{LN} / 0 – 692Vac _{LL}
For higher power configurations, contact factory	

4.15.2 Technical Specifications 400V Range

AC OUTPUT											
Voltage											
AC Only Range	0 - 400 V L-N rms / 0 - 692V L-L rms										
Programming Resolution	0.01 V										
Accuracy	$\pm (0.25\% + 0.25 * f \text{ (kHz)}) \text{ F.S.}$										
Constant Power Range	From 40% to 100% of Voltage Range: 160Vac L-N to 400Vac L-N										
External Voltage Sense	Automatically scaled for 400Vac Range										
Frequency											
Range	45.00 – 1000.0 Hz Linear voltage derating from 45Hz to 15Hz. Linear current derating from 1000Hz to 1200Hz. Extended Frequency Ranges are not available on T Option AC range										
Programming Resolution ¹	0.01 Hz										
Accuracy	$\pm 0.01\%$										
Current²											
Range	Available RMS Current per phase is scaled by transformer ratio. E.g. for 3150AFX, max current at 400Vac L-N is $(41.7 * \frac{3}{4}) = 31.27\text{Arms}$ in 3 Phase mode										
Current Overload	Available 30% Current overload for up to 2.0 seconds when enabled.										
<p>Note 1: FREQUENCY PROGRAM RESOLUTION FOR EXPORT MODELS (-4LE, -2LE -4AGE, -2AGE): Per U.S.A. Bureau of Industry and Security, ECCN 3A225, frequency control is limited to no better than 0.2% at frequencies of 600 Hz. or more for unrestricted export products. To meet that requirement, frequency programming in all AFX-xxE models has three resolution ranges, which round the frequency to the nearest increment, as defined in the table below.</p> <p>Frequency Resolution for Export Models</p> <table border="1" style="margin-left: 40px;"> <thead> <tr> <th>Range</th> <th>Resolution</th> </tr> </thead> <tbody> <tr> <td>15.00 - 99.99 Hz</td> <td>0.01 Hz</td> </tr> <tr> <td>100-599.9 Hz</td> <td>0.1 Hz</td> </tr> <tr> <td>600 - 999 Hz</td> <td>2.0 Hz</td> </tr> <tr> <td>1000 - 1200 Hz</td> <td>5.0 Hz</td> </tr> </tbody> </table>		Range	Resolution	15.00 - 99.99 Hz	0.01 Hz	100-599.9 Hz	0.1 Hz	600 - 999 Hz	2.0 Hz	1000 - 1200 Hz	5.0 Hz
Range	Resolution										
15.00 - 99.99 Hz	0.01 Hz										
100-599.9 Hz	0.1 Hz										
600 - 999 Hz	2.0 Hz										
1000 - 1200 Hz	5.0 Hz										
<p>Note 2: Refer to AC Mode Voltage / Current rating charts Figure 4-14 and Error! Reference source not found. on following pages.</p>											

TRANSFORMER OPTION – 400V AC VOLTAGE RANGE

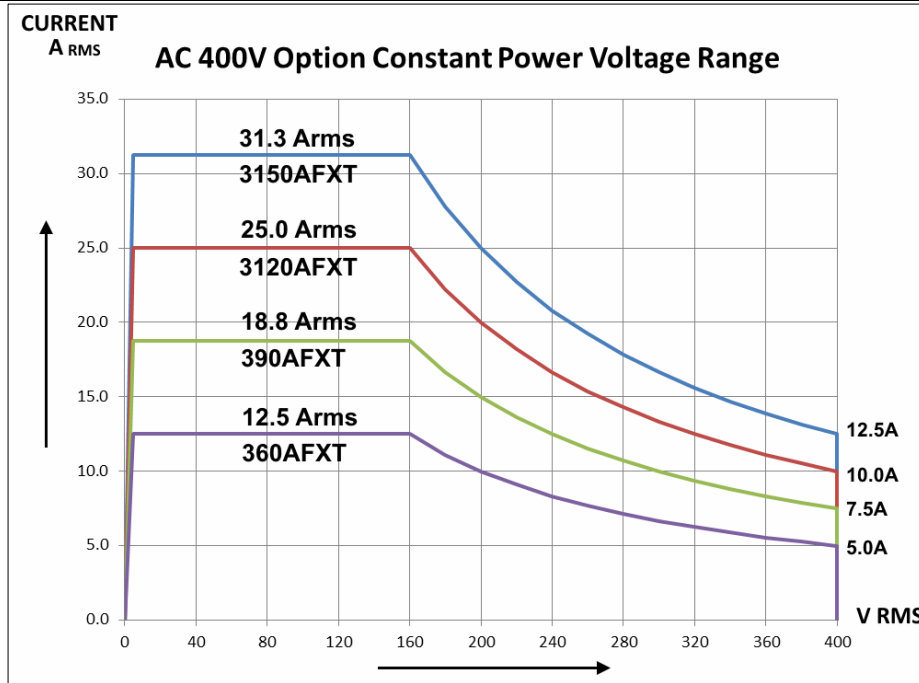

Figure 4-14: Voltage vs Current Rating 400V Range – 3 Phase Mode

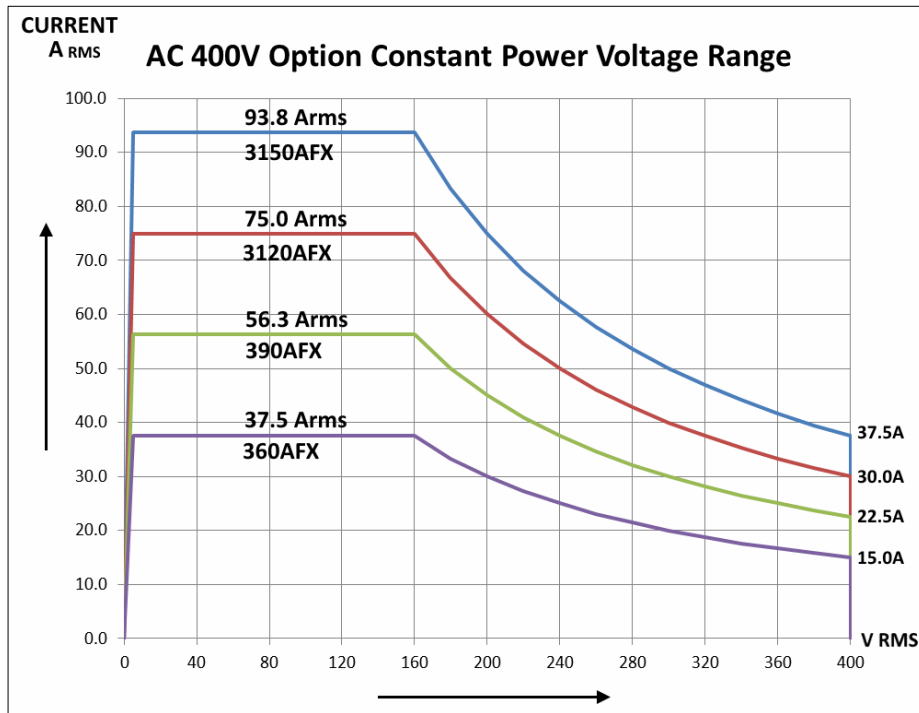

Figure 4-15: Voltage vs Current Rating 400V Range – 1 Phase Mode

4.16 Series Output Voltage Range (S Option)

4.16.1 Series Mode AFSX description

If more than 300Vac L-N is required, the S version of the AFX or AFSX master can be connected in series with an AFX Auxiliary unit to double the available voltage range from 300Vac LN to 600Vac LN. The master unit **MUST** be an “S” version which has to be ordered from the factory as an AFSX.

AFSX masters are similar to a standard AFX master but implement the following changes:

- An isolated output neutral connections for phase A, B and C rather than a common neutral. Note that the output terminal pin orientation on an AFSX model differs from a standard AFX model. The Line and neutral output of each phase are adjacent to each other and the three neutrals are isolated. See figure Figure 4-17 below.
- A re-scaled External and Internal Voltage Sense to accommodate the higher output voltage created by the two units in series.
- The AUX I/O interface (DB25) is used to control the SPMS Option hardware. Interface cables & pass through DB25 included.

Since two AFX units are required for series operation, the lowest available series mode AFX power configuration consists of two 6kVA/6kW units to a total of 12kVA/kW.

The highest available power level for a two unit Series system consists of one 3150AFXS-xAG and one 3150AFX-xNC for a max power output of 30kVA/kW.

Two or three sets of Series AFX units can be parallel for higher power levels as needed. The maximum confirmation is thus 90kVA/kW.

Note: DO NOT turn on the SPMS controller located at the top of the cabinet while the AFSX system is in use.



Figure 4-16: 60KVA AFSX Series with SPMS Option

4.16.2 AFSX & AFX with Option W output connector pin assignments

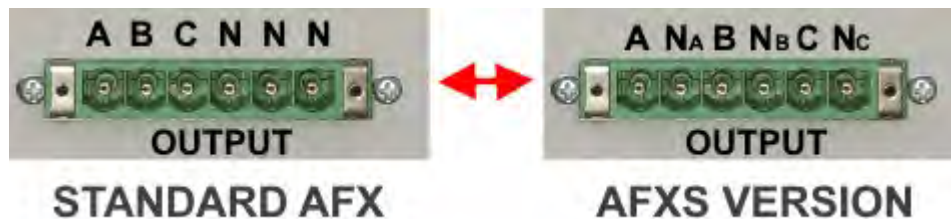

Figure 4-17: Standard AFX model vs AFSX & AFX-W Model Output Connector pins

4.16.3 Series versus Parallel Connection Modes

The following two figures show a Parallel mode two AFX sytem output connection diagram and a Series mode AFX output connection to illustrated the difference.

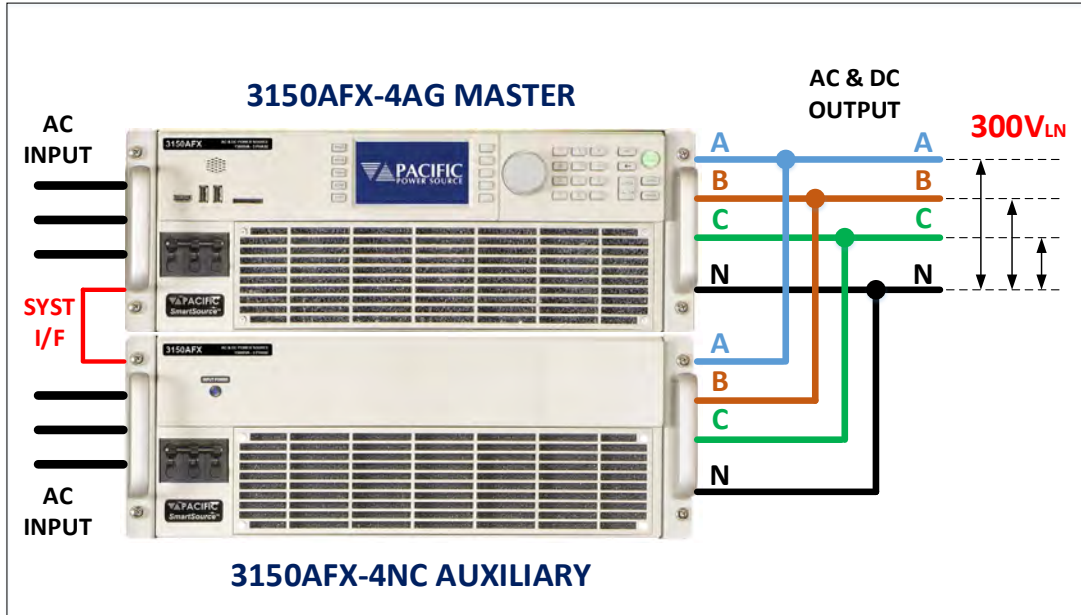

Figure 4-18: Parallel Configuration – 30 kVA/kW 300Vac LN / 520Vac LL

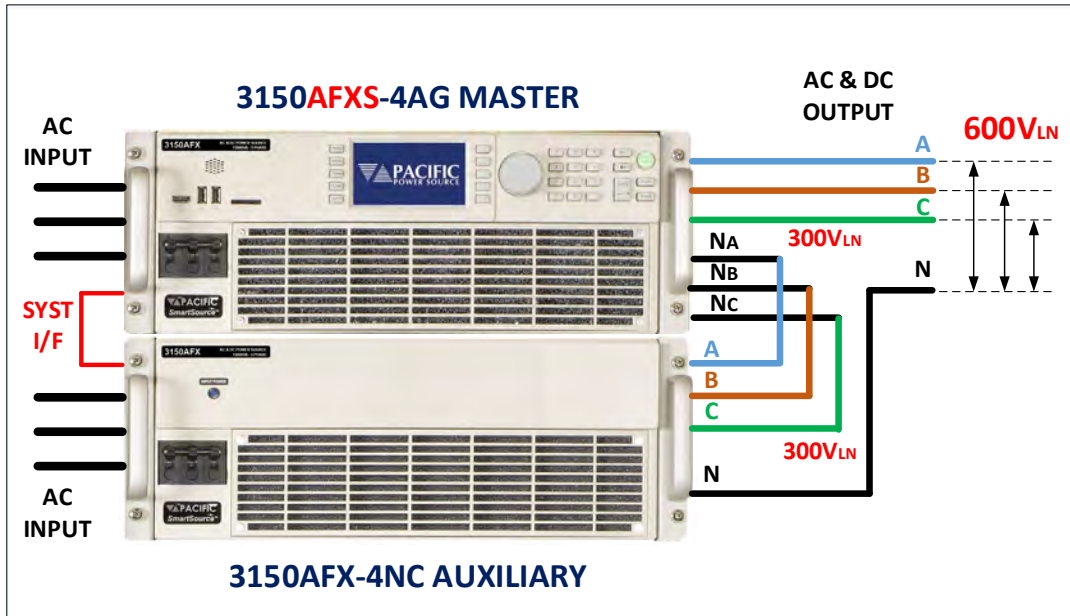
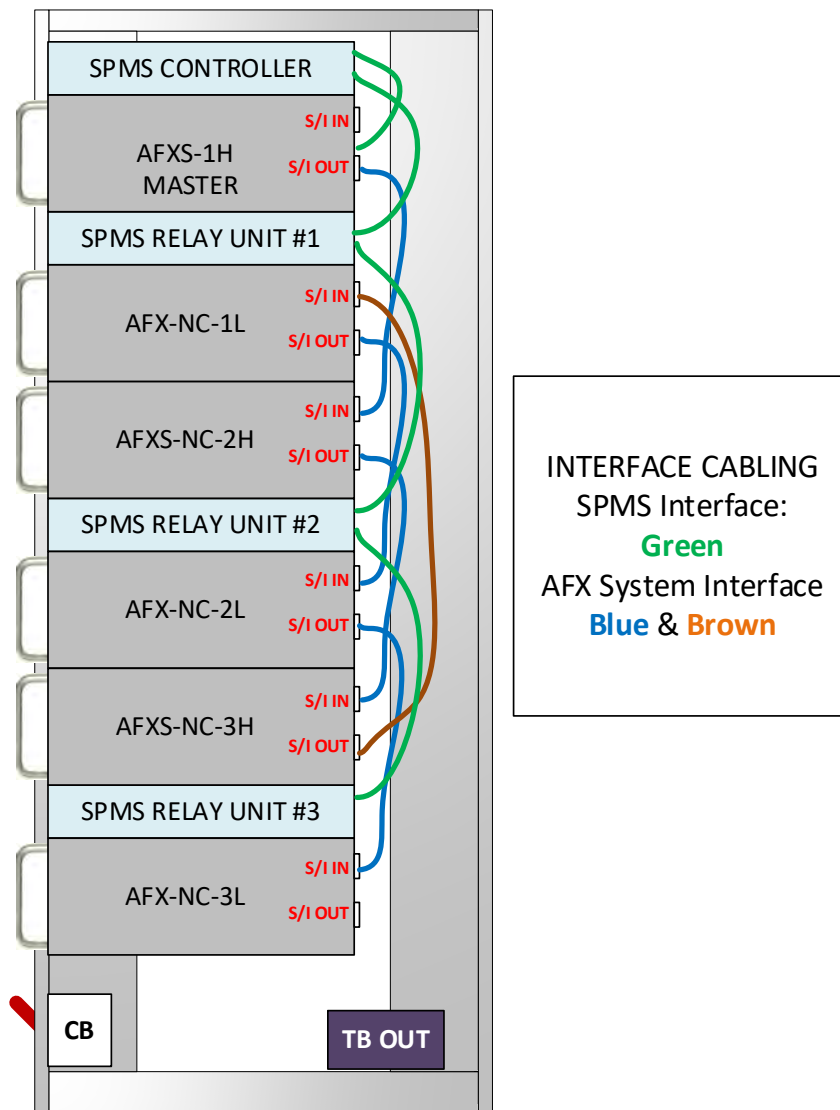

Figure 4-19: Series Configuration – 30 kVA/kW 600Vac LN / 1040Vac LL

4.16.4 SPMS Series Configuration switch option

Series systems can either be hardwired for series operation only. For applications where both 600Vac LN and 400Vac LN voltage ranges are required can be configured with the SPMS (Series Parallel Mode Switch) option. This switch reconfigures output wiring between series and parallel modes under software or front panel control. This allows both high voltage, lower current or lower voltage higher current configuration to be selected.

Series system are typically installed in a 19" instrument rack with all input and output wiring and control interface cabling installed and tested. This applies to both Series only cabinet systems and SPMS Mode cabinet systems.



4.16.5 Standard Series Output Cabinet System Configurations

MODEL	POWER	V RANGE	CONSISTS OF	AC INPUT	19" CAB.
3180AFXS-2AG or 3180AFXS-4AG	18kVA	0 - 600 Vac LN 0 - 1040 Vac LL	1x 390AFXS-xAG Master 1x 390AFX-xNC Auxiliary	208Vac, 3 ϕ or 380~480Vac, 3 ϕ	28U
3240AFXS-2AG or 3240AFXS-4AG	24kVA	0 - 600 Vac LN 0 - 1040 Vac LL	1x 3120AFXS-xAG Master 1x 3120AFX-xNC Auxiliary	208Vac, 3 ϕ or 380~480Vac, 3 ϕ	28U
3300AFXS-2AG or 3300AFXS-4AG	30kVA	0 - 600 Vac LN 0 - 1040 Vac LL	1x 3150AFXS-xAG Master 1x 3150AFX-xNC Auxiliary	208Vac, 3 ϕ or 380~480Vac, 3 ϕ	28U
3600AFXS-4AG	60kVA	0 - 600 Vac LN 0 - 1040 Vac LL	1x 3150AFXS-4AG Master 1x 3150AFXS-4NC Auxiliary 2x 3150AFX-4NC Auxiliary	380~480Vac, 3 ϕ	28U
3900AFXS-4AG	90kVA	0 - 600 Vac LN 0 - 1040 Vac LL	1x 3150AFXS-4AG Master 2x 3150AFXS-4NC Auxiliary 3x 3150AFX-4NC Auxiliary	380~480Vac, 3 ϕ	36U
SPMS Option	Automatic Series and Parallel Mode Configuration Switch allows switching between Series or Parallel modes without the need to reconfigure output wiring. Must be specified at the time of original order.				

4.16.6 Selecting the Series Mode Configuration

If the SPMS option is installed, the mode of operation can be selected from the front panel or the remote control interface. From the front panel, select the CONF menu key and scroll to the bottom of CONFIGURATION SCREEN 1 to turn the series output configuration ON or OFF. When ON, the output of all AFXS/AFX-NC pairs will be connected in series mode. When OFF, they will be in parallel mode instead. The total output power remains the same either way.

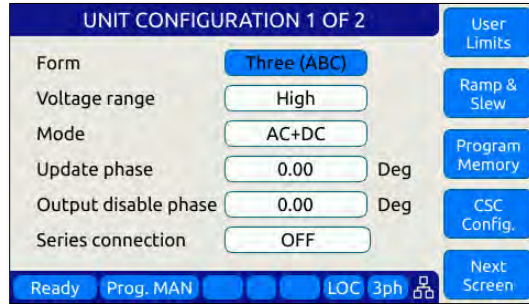

The browser interface can also be used to change between series or parallel mode by selecting the CONFIGURATION -> UNIT SETTINGS menu entry. The Series connection state is shown in the lower right corner of the screen.

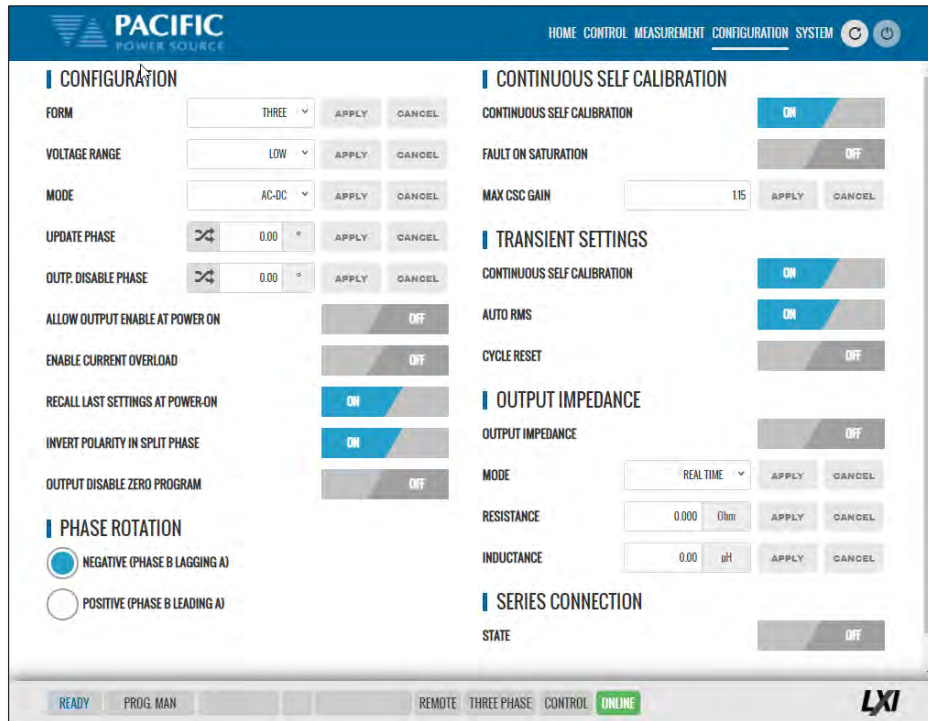

For remote control commands that apply to the AFXS Series mode of operation, refer to section 8.12, “AFXS Series Mode Commands” on page 414.

4.17 IEC413 Option

This option adds inter harmonic generation to an AFX Master unit. Models with this option have the letter “C” in the model number designation immediately following the –“AG” part. For example, 3150AFX-4AGCE.

This option removed to user programmable features from the standard AFX feature set:

- User programmable output OVP level. The OVP level is fixed at the maximum allowable setting.
- User programmable Peak output current protection. The peak level is fixed at the maximum level.

Note: Disabling of these features does not affect reliability of the power source.

Interharmonics control is available through SCPI bus commands only. No front panel user interface is included with this option.

This interharmonic waveform generator may be used to support IEC61000-4-13 harmonics and interharmonics immunity testing of an EUT. The IEC413 Test Sequence suite for PPSC Test Manager Windows 10 software is included with this option. This test sequence handles all harmonics and interharmonics frequency steps and amplitudes programming.

Technical Specifications:

IEC413 Option	
Frequency Range	15.00 Hz to 10,000 Hz
Amplitude Range	0.00 Vac to 300.00 Vac
Phase Angle Programming	0.0° to 359.9° with respect to Phase fundamental
Available on Models	3xxxAFX-2AGC or 3xxxAFX-4AGC models only

5 Unpacking and Installation

5.1 Inspection

The AFX Series® of AC power sources are carefully inspected before shipment. If instrument damage has occurred during transport, please inform Pacific Power Source' nearest sales and service office or representative.

All AFX models require three-phase AC input and are furnished with a compression terminal block for AC input. A suitable line cord and power disconnect is required (but not included) to connect these power supplies to the mains.

Refer to "check line voltage" to check the line voltage selection and fuse type.

Note: For input and output connections to AFX cabinet systems, refer to Section 5.15, "Cabinet Systems" starting on page 80.

5.2 Lifting and Carrying Instructions



CAUTION

THIS UNIT IS HEAVY. Two persons are required to lift or carry this unit. DO NOT attempt to lift alone. DO NOT use the front panel rack handles alone to lift this unit. The unit must be supported in front and back when carrying.



AVERTISSEMENT

CET EQUIPEMENT EST LOURD. Deux personnes sont requises pour transporter ou soulever cet équipement. NE PAS tenter de soulever ou déplacer seul. NE PAS utiliser les poignées en face avant pour soulever l'appareil. L'équipement doit être pris en charge à l'avant et à l'arrière pour le transport.

This equipment weighs over 100 lbs. / 50 Kg and requires two persons to lift or carry. To remove the equipment from its packaging, use the provided handgrip openings on either side of the unit to lift the unit from its packaging and place it on a suitable surface that is rated to support the weight of the unit. Two persons are required to remove the AFX unit from its packaging, one on each long side of the box. Refer to Figure 5-2 for reference.

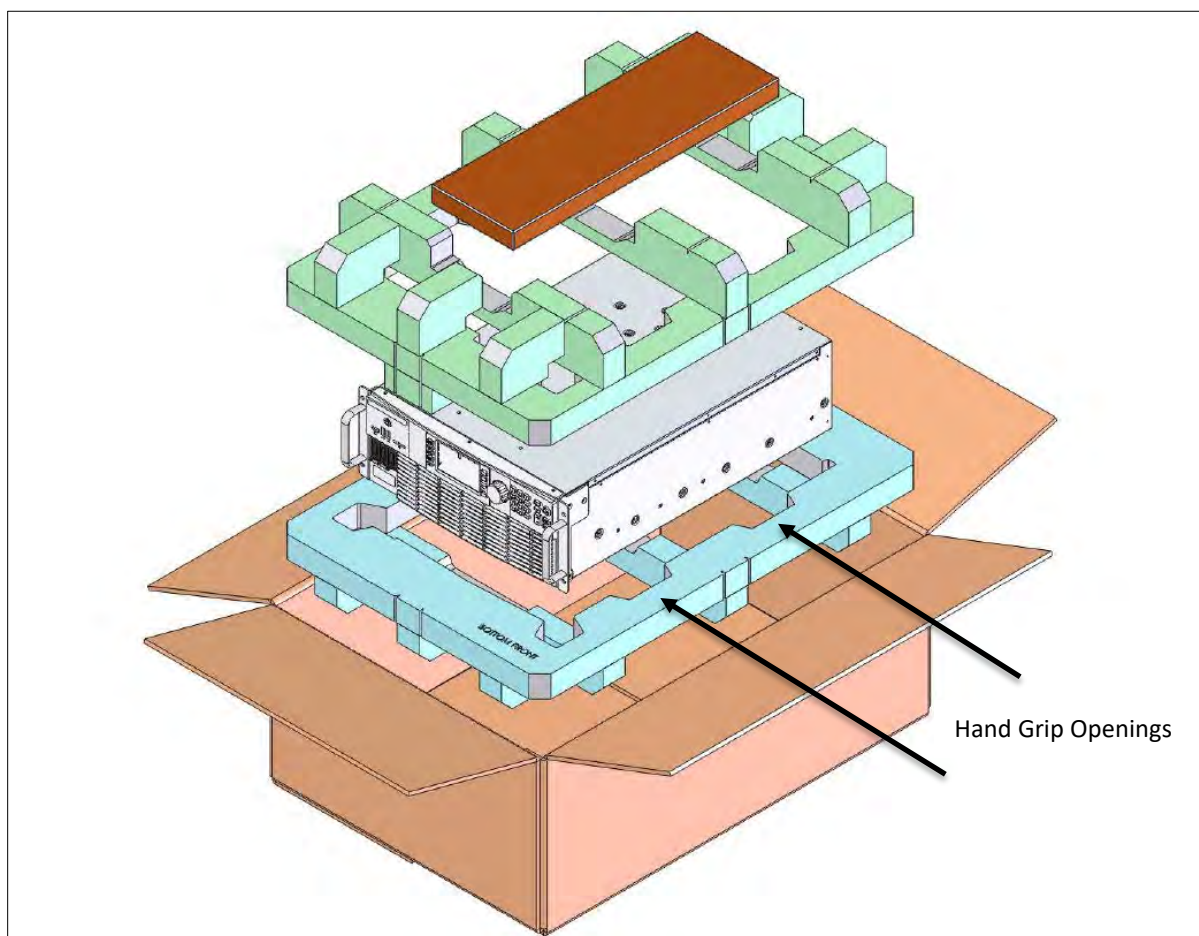

Figure 5-2: Exploded view of AFX unit packaging

If the unit is to be installed in an instrument rack, the straps may be removed. In that case, a suitable lift must be used to position the unit at the desired rack height and pushed in place using either rack slides or L-brackets (not included with the unit). The front panel handles may be used to pull or push the unit in or out of a rack space only.

Note: The front panel handles are not designed to carry the entire unit. It must be supported on front and back or both sides by two persons when being handled.

5.3 Verify Correct AC Input Line Voltage

The AFX Series® power supply can be ordered with a range of 3 phase AC input voltage configurations. Prior to connecting the AC power source to the local mains, it is important to check the type label on the unit to verify that its AC input configuration matches the local utility power.

Do not connect the power supply to the mains if the AC input voltage, phasing and frequency does not match.



CAUTION

DO NOT CONNECT A 208 – 240 V AC INPUT AFX MODEL TO A 380V, 400V OR 480V OR HIGHER THREE PHASE UTILITY LINE VOLTAGE AS DAMAGE TO THE UNIT MAY OCCUR.

DO NOT CONNECT A 380 – 480 V AC INPUT AFX MODEL TO A 208V TO 240V THREE PHASE UTILITY LINE VOLTAGE AS THE UNIT WILL NOT OPERATE.



AVERTISSEMENT

NE PAS CONNECTER UNE 208-240 V AC ENTRÉE AFX MODÈLE À UN 380V, 400V OU 480V OU PLUS DE TROIS PHASES UTILITAIRE TENSION EN PANNE QUI PEUT SE PRODUIRE.

NE PAS CONNECTER UNE 380 - 480 V AC ENTRÉE AFX MODÈLE À UN 208V TO 240V TRIPHASE UTILITAIRE TENSION QUE L'APPAREIL NE FONCTIONNE PAS.

5.4 AC Input Connections



CAUTION

The AC input connections must include a disconnect device (an external switch or circuit-breaker) as part of the installation. The disconnect device must be suitably located and easily reached and must be marked as the disconnecting device for the equipment. The disconnect device must disconnect all line conductors simultaneously.

An external overcurrent protection device must be provided (by, e.g., fuses or circuit breaker). The breaking capacity of the overcurrent protection device should be compatible with the current rating of the installation.

A minimum of basic insulation is required between mains-connected parts of opposite polarity on the supply side of the overcurrent protection device.

Overcurrent protection devices shall not be fitted in the protective conductor. Fuses or single pole circuit-breakers shall not be fitted in the neutral conductor of multi-phase equipment.

Installation should be in accordance with ANSI/NFPA 70, NEC.

After disconnecting grid power, ALWAYS wait at least 1 minute, then use a Digital Voltmeter (DMM) in VDC Mode to check for any residual DC voltage from each Line terminal to the Chassis ground stud to check for safe voltage levels (< 5 Vdc) before touching the unit or any terminal blocks or pins.



AVERTISSEMENT

Les connexions d'entrée AC doivent inclure un dispositif de déconnexion (un commutateur externe ou disjoncteur) dans le cadre de l'installation. Le dispositif de déconnexion doit être convenablement situé et facilement accessible et doit être marqué comme le dispositif de déconnexion de l'équipement. Le dispositif de déconnexion doit déconnecter tous les conducteurs de ligne simultanément.

Un dispositif de protection de surintensité externe doit être fourni (par exemple, par des fusibles ou coupe-circuit). Le pouvoir de coupure du dispositif de protection contre les surintensités doit être compatible avec le courant nominal de l'installation.

Un minimum d'isolation de base est nécessaire entre les parties de réseau connecté de polarité opposée sur le côté d'alimentation du dispositif de protection contre les surintensités.

Les dispositifs de protection contre les surintensités ne doivent pas être installés dans le conducteur de protection. Fusibles ou simples disjoncteurs ne doivent pas être installés dans le conducteur neutre des équipements multi-phasés.

L'installation doit être conforme à la norme ANSI / NFPA 70, NEC.

Après avoir débranché l'alimentation du réseau, attendez TOUJOURS au moins 1 minute, puis utilisez un voltmètre numérique (DMM) en mode VDC pour vérifier toute tension CC résiduelle de chaque borne de ligne sur le plot de masse du châssis pour vérifier les niveaux de tension sécurisés (<5 Vcc) avant de toucher l'unité ou des borniers ou des broches.

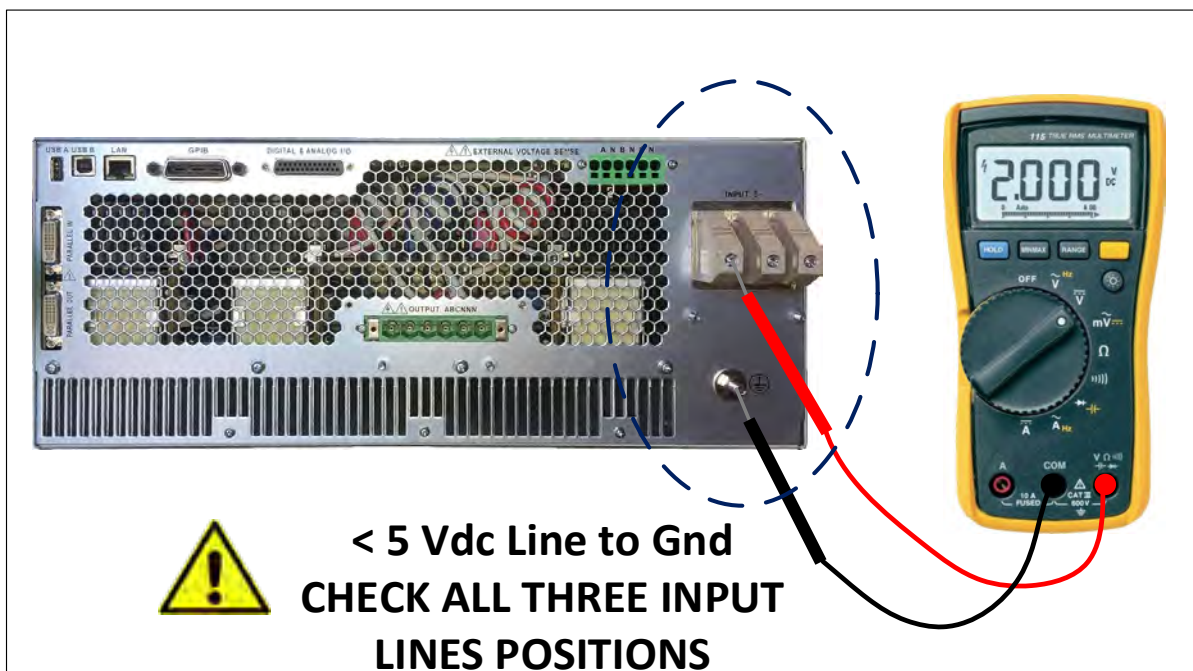

Consult the table below for recommended wire size by model number and AC input rating.

MODEL	INPUT VOLTAGE	INPUT CURRENT	RECOMMENDED INPUT SERVICE	MINIMUM COPPER WIRE SIZE, 75°C RATED
390AFX-2	208 V ac, 3~	37 A rms, max	40 A rms	10 mm ² (AWG 8)
3120AFX-2	208 V ac, 3~	48 A rms, max	50 A rms	10 mm ² (AWG 8)
3150AFX-2	208 V ac, 3~	55 A rms, max	60 A rms	16 mm ² (AWG 6)
390AFX-4	380/400 V ac, 3~ 480 V ac, 3~	20 A rms, max 16 A rms, max	25 A rms 20 A rms	6 mm ² (AWG 10) 4 mm ² (AWG 12)
3120AFX-4	380/400 V ac, 3~ 480 V ac, 3~	27 A rms, max 22 A rms, max	30 A rms 25 A rms	6 mm ² (AWG 10) 6 mm ² (AWG 10)
3150AFX-4	380/400 V ac, 3~ 480 V ac, 3~	30 A rms, max 24 A rms, max	35 A rms 30 A rms	10 mm ² (AWG 8) 6 mm ² (AWG 10)

Table 5-1: AC Input Wire Size Table

Note: Maximum wire size that will fit the AC Input terminal block is AWG 4.

AWG	Diameter		Turns of wire, without insulation		Area	
	(in)	(mm)	(per in)	(per cm)	(kcmil)	(mm ²)
4	0.2043	5.189	4.89	1.93	41.7	21.2

The AC input connections must be made at the rear panel AC terminal block. This input block has a removable safety cover that must be installed when the instrument is used on a bench or is otherwise accessible at the rear. If mounted in a cabinet with a locked door or screen, the AC input safety cover may be omitted if needed.

The following wire strip lengths are required for the AC input wires listed.

L1, L2, L3 Wires:	11/16", 17 mm
Neutral, Ground Wires:	3/4", 19 mm

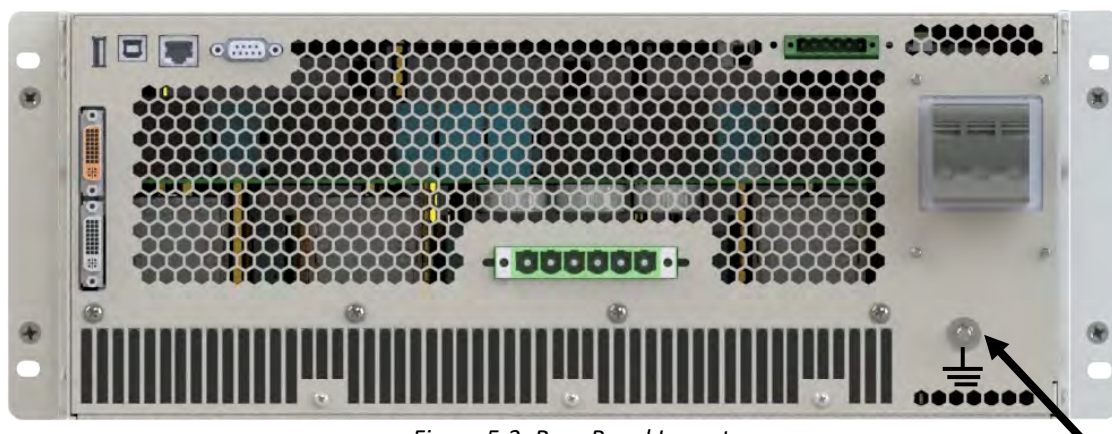
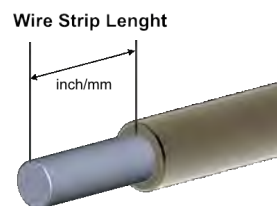

Figure 5-3: Rear Panel Layout

EARTH GROUND

The AC input terminal phasing is marked on the rear panel and shown in the illustration below. A four wire mains connection is required. (L1, L2, L3 and Earth Ground). Ground connection is located directly below the AC Line input terminal block as shown in Figure 5-3 above.

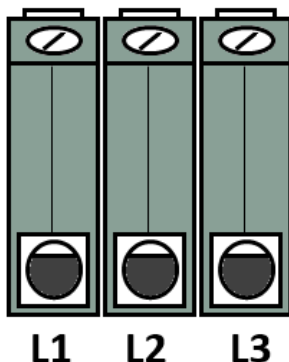

Figure 5-4: AC Input Terminal Block - Rear Panel

5.5 Grounding Requirements

5.5.1 Chassis Ground Connection Required



CAUTION

SHOCK HAZARD: Equipment must be grounded.



AVERTISSEMENT

RISQUE DE CHOC: l'équipement doit être mis à la terre.

The unit **MUST** be grounded via the AC Input. A line cord with proper Earth Ground must be used at all times. Correct grounding of your electrical system infrastructure according to applicable national standards must also be observed.

5.5.2 Output Neutral Grounding

The output neutral terminals of the power source are **NOT** connected to earth ground but rather floating. This allows the output of the power source to float with respect to ground. Some loads will have their neutral input grounded, which will result in the power source neutral being grounded through the load. Alternatively, the user may ground the output neutral terminals himself by running a suitable wire size from one of the output neutral terminals to the ground stud on the rear panel of the power source as shown in Figure 5-5.

Grounding the output neutral can help reduce common mode noise at the output of the power source.

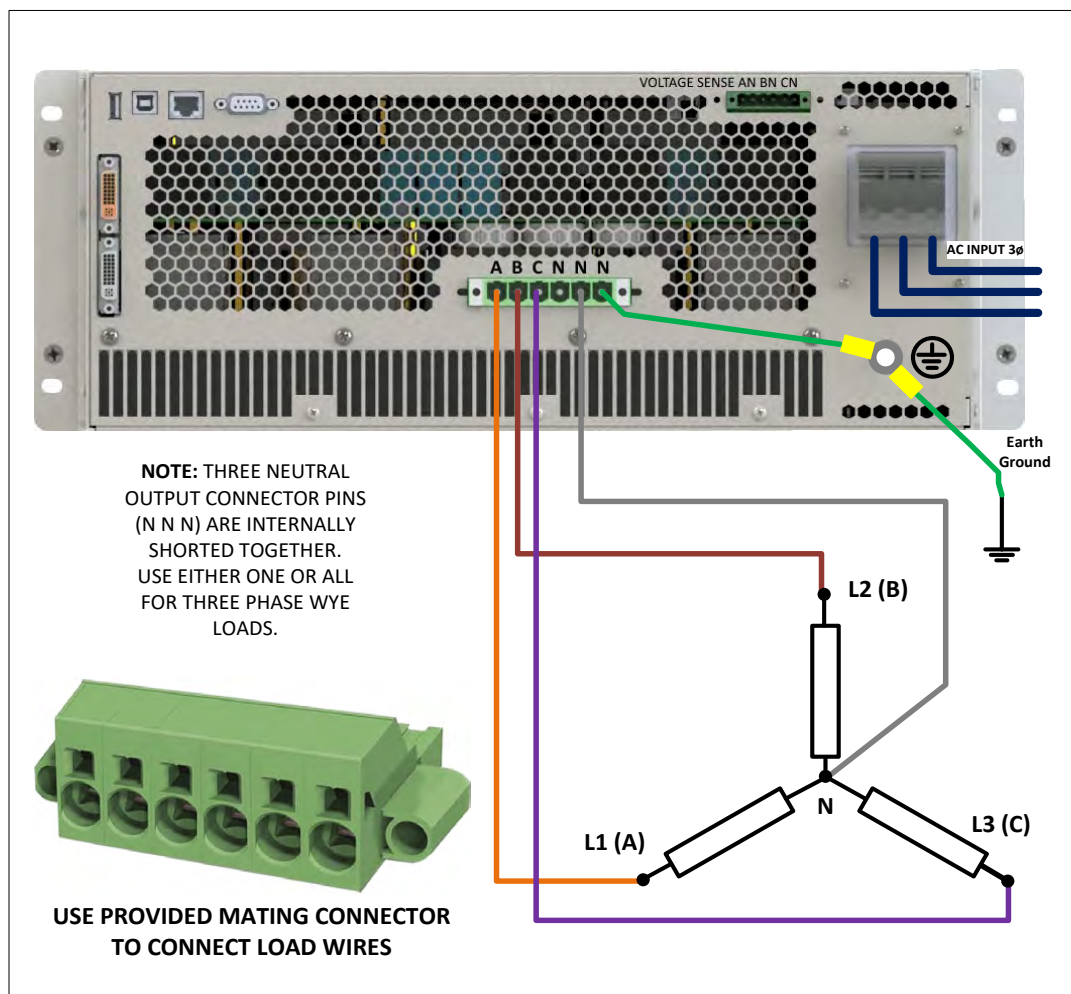

Figure 5-5: Grounding Floating Neutral Output

5.6 AC Input Circuit Breaker

This product is fitted with a mains input circuit breaker on the left hand side of the front panel. The power off position of the circuit breaker handle is marked “O”. The power on position of the circuit breaker is marked “I”.

5.7 Bench Use



CAUTION

When placing this instrument on a workbench or table, ensure the maximum weight rating of the bench/table exceeds the actual weight of the unit.



ATTENTION

Lorsque l'appareil est placé sur un banc de travail ou une table, s'assurer que la capacité de charge maximale du banc / table dépasse le poids réel de l'appareil.

The AFX Series® chassis is not equipped with surface protection feet as it is intended primarily for 19" rack mount use. When used on a bench, use care not to damage bench surface by sliding AFX unit.

5.8 Rack Mounting

The AFX Series® chassis is designed to be rack mounted in a standard 19-inch rack for system applications. Zero stacking with other units or test equipment is possible. The weight of the unit **MUST** be supported properly. Either use rack slides or L brackets of sufficient weight rating that are compatible with the dimensions of the cabinet used.

AFX Series® models with an output power rating above 15KVA are available as factory installed 19" instrument cabinet systems including input and output wiring to connection terminal blocks at the bottom rear of the cabinet.

Customers (i.e. System Integrators) preferring to install one or more AFX units in their own cabinet systems can order Master and multiple Auxiliary parallel systems as a **KIT** with no 19" cabinet or wiring included.

5.9 Airflow

The AFX Series® of AC power sources are cooled by drawing in air through the front and out at the back of each unit. Do not AFX units install in a manner that blocks the free flow of air such as in a cabinet with a solid rear door. Allow a minimum of 6" (15 cm) free of obstructions behind the unit to prevent overheating.

5.10 Sound Levels



CAUTION

Sound pressure level from power source may exceed 85 dBA.

Sound pressure level should be measured both at the operator's position in normal use and at whatever point 1 meter from the power source enclosure that has the highest sound pressure level.

The installer shall provide measures to reduce the sound pressure level at the operator's point of use to a safe level. These measures may include the fitting of noise-reducing baffles or hoods or provision of protective earpieces.



AVERTISSEMENT

Le niveau sonore de l'appareil peut dépasser 85 dBA.

Le niveau sonore doit être mesuré à la fois à la position de l'opérateur en utilisation normale et quelque soit le point à 1 mètre de l'enceinte de l'appareil qui a le niveau sonore le plus élevé.

L'installateur doit prendre des mesures visant à réduire le niveau sonore au point d'utilisation de l'opérateur. Ces mesures peuvent inclure la mise en place de hottes antibruit, ou la fourniture d'oreillettes de protection.



When the equipment is operated at or near full rated output power, fan speed will be at its highest and corresponding noise levels will be higher. Operators should wear ear protection while exposed to these levels of sound.

5.11 Cleaning



CAUTION

BEFORE you clean the unit, switch the unit off at the front panel breaker AND remove all mains power using the mains disconnect.

- Please do NOT use any organic solvent capable of changing the nature of the plastic such as benzene or acetone.
- Please ensure that no liquid is allowed to penetrate this product.



ATTENTION

AVANT de nettoyer l'appareil, mettez l'appareil hors tension au niveau du disjoncteur de face avant ET retirez tout câble d'alimentation secteur.

- Ne pas utiliser **de** solvant organique capable de changer la nature de la matière plastique tel que le benzène ou l'acétone.
- Veiller à ce qu'aucun liquide ne pénètre à l'intérieur de l'appareil

To clean this product, use a soft or slightly damp cloth.

5.12 Air Intake Filter Removal and Cleaning

Units equipped with a removable air intake filter must have their filter material cleaned on a regular basis. A six-month cleaning interval is recommended. For units deployed in particularly dirty environments, this cleaning interval should be shortened to three months or less to prevent the air filter from clogging up with dirt. This applies to both Master units and Auxiliary units.

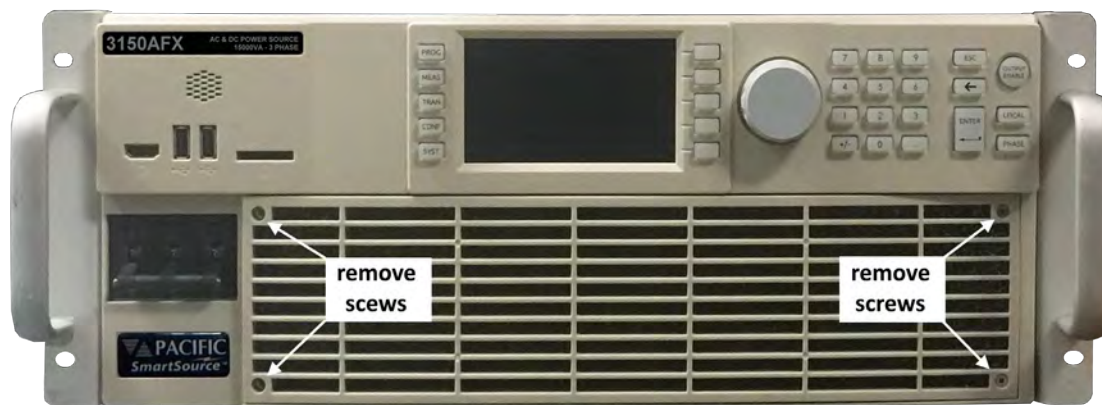

Figure 5-6: Air Intake Filter Removal

5.12.1 Air Filter Removal

To remove the air filter, proceed as follows:

1. Turn the unit off first.
2. Using a small Philips screwdriver, remove the four M3 Philips screws from each corner of the filter panel on the front of the unit.
3. Pull the filter panel toward you carefully and remove the filter material.

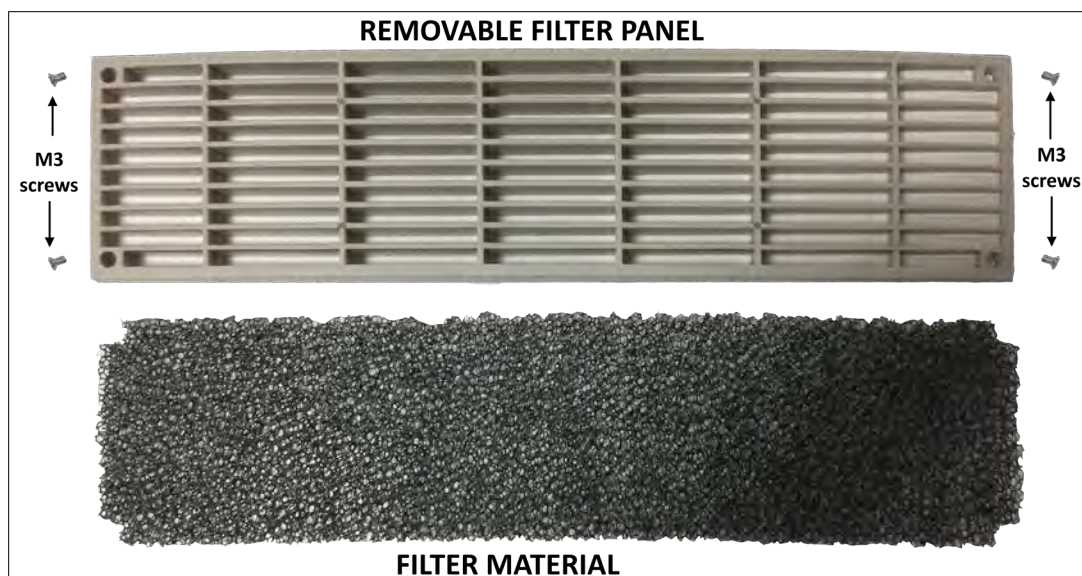

Figure 5-7: Air Intake Filter and Filter Panel

5.12.2 Filter Cleaning

Use warm water and some mild detergent to rinse all dirt out of the filter material. Allow the filter to dry for 2 hours or more till fully dry before re-installing. If the filter material is too dirty to clean, replace with a new filter. Contact customer service for replacement filters.

5.12.3 Air Filter Installation

To reinstall the filter material, proceed as follows:

1. Place the cleaned filter material against the lower part of the units front panel.
2. Line up the filter materials so the corner cut-outs align with the four corners
3. Install the removable filter panel using the four M3 Philips screws.

5.13 Liquids

The AFX Series® of AC power sources offer no protection against liquid spills. Do not install where chemicals are used or where liquids could spill into the unit.

5.14 Load Connections



CAUTION

HAZARDOUS OUTPUT: The power source output may be set to hazardous voltage levels. It provides basic isolation from the AC input mains. Therefore, the output must always be considered hazardous. Connections must be inaccessible to the operator in all situations when AC input mains voltage is applied.

Always disconnect power supply from the mains before connecting or disconnecting to the hazardous output terminals.



AVERTISSEMENT

SORTIE DANGEREUSE: La sortie de l'appareil peut être réglée à des niveaux de tension dangereux. L'appareil fournit une isolation de base du réseau d'entrée AC. Par conséquent, la sortie doit toujours être considérée comme dangereuse. Les connexions doivent être inaccessibles à l'opérateur dans toutes les situations où la tension d'entrée secteur est appliquée.

Toujours débrancher l'alimentation secteur avant de connecter ou déconnecter les bornes de sortie dangereuses.

The AC power source can be configured for either single-phase output or three-phase output.

Note: The External Voltage Sense connector always has three phase and three neutral connections but in single-phase mode of operation, only the A phase and one neutral connection are required.

5.14.1 Output Wiring and Recommended Wire Sizing

Connections from the AC source output terminal to the load should be made using the provided mating output connector. This connector is safety rated and does not require an output cover. It **MUST** be used when connecting load wires.

Load currents are a function of the load so care must be taken by the user to select appropriately size output wires in accordance with local electrical codes.

Note: Since local electrical codes vary by location, Pacific Power Source **DOES NOT INCLUDE** any AC input or AC output wires with its power sources.

Maximum output voltage and current ratings of the available power source models are shown in section 4, "Technical Specifications" and should be consulted when determining correct wire size. Also consider the voltage insulation rating of the load wires and External voltage sense wires used.

5.14.2 Three Phase Wye or Split Phase Load Output Connection

Connection of a three-or split phase load requires the mating connector provided in the AFX Series® ship kit. This six-pole connector uses a spring loaded wire attachment system. To unlock a position, use a small screwdriver or pin to push down in the square hole located directly above each connection. Once you push in, you will feel to spring unlatch. Now push the stripped wire end into the connector and pull out the small screwdriver or pin. This will release the spring locking down the wire. Use a pull test to make sure the wire is clamped down securely.



Note: The output terminal diameter is 16 mm² so largest wire gauge that can be used is AWG6.

AWG	Diameter		Turns of wire, without insulation		Area	
	(in)	(mm)	(per in)	(per cm)	(kcmil)	(mm ²)
6	0.1620	4.115	6.17	2.43	26.3	13.3

Repeat for the three (3 Phase load) or two phase (Split phase load) wires and the neutral wire. Note that the three neutral positions on the rear panel output power connector are all shorted together inside the AFX. Thus, there is only one neutral, which is common for all output phases. For balanced three phase Wye loads, only one of these three neutral output positions has to be connected to the load’s neutral position.

For split phase load applications, the A and B phases are connected to the load. The C phase load and C phase Voltage sense connections are not used.

The requisite WYE load output wiring is shown in Figure 5-8 using internal voltage sense and Figure 5-9 when using external voltage sense.

Note Load and sense wiring are **NOT** included with the power source and must be supplied by the end-user.

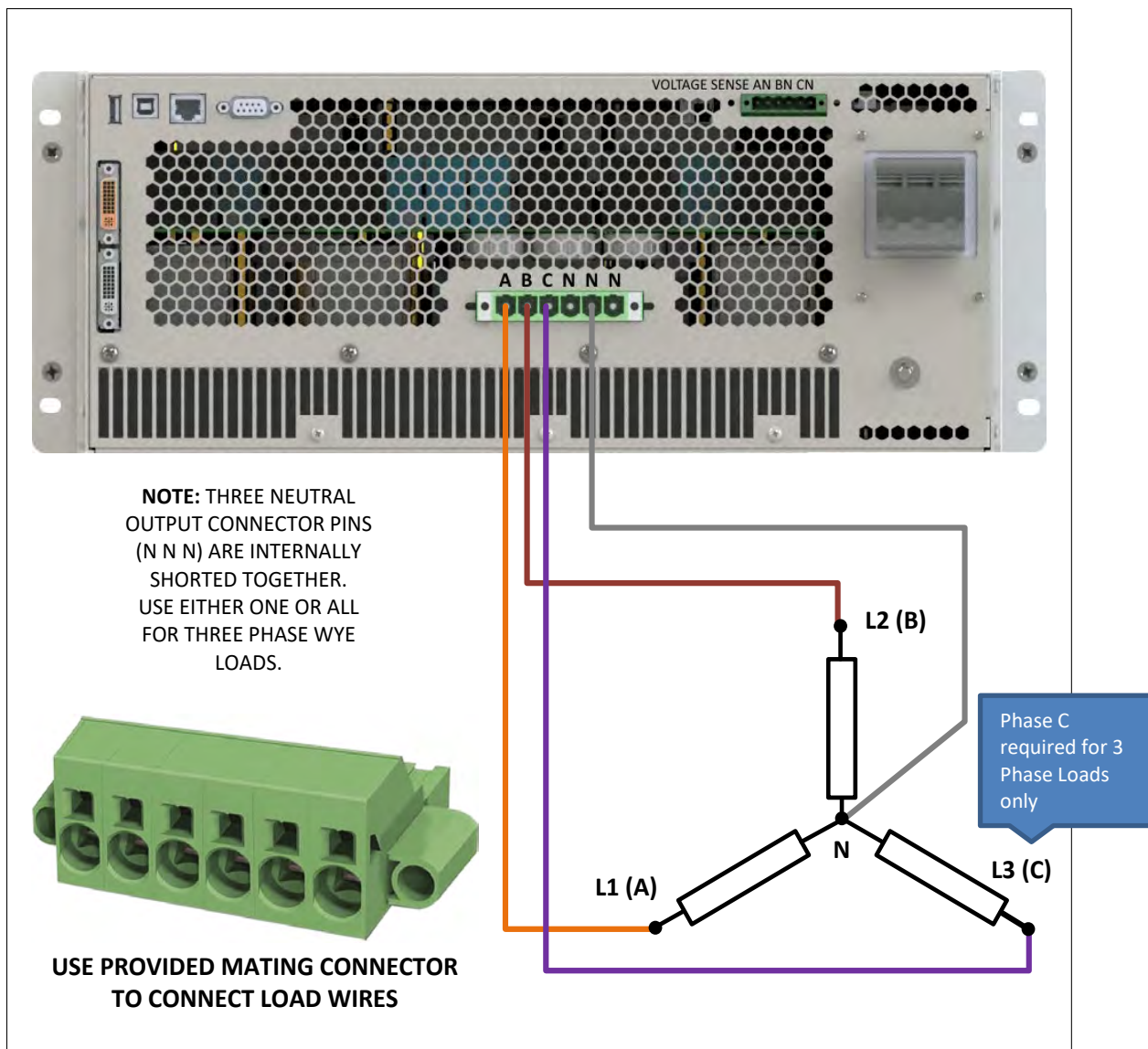

Figure 5-8: Three Wye or Split phase Load Output Connections – Internal Voltage Sense

Note Load and sense wiring are **NOT** included with the power source and must be supplied by the end-user.

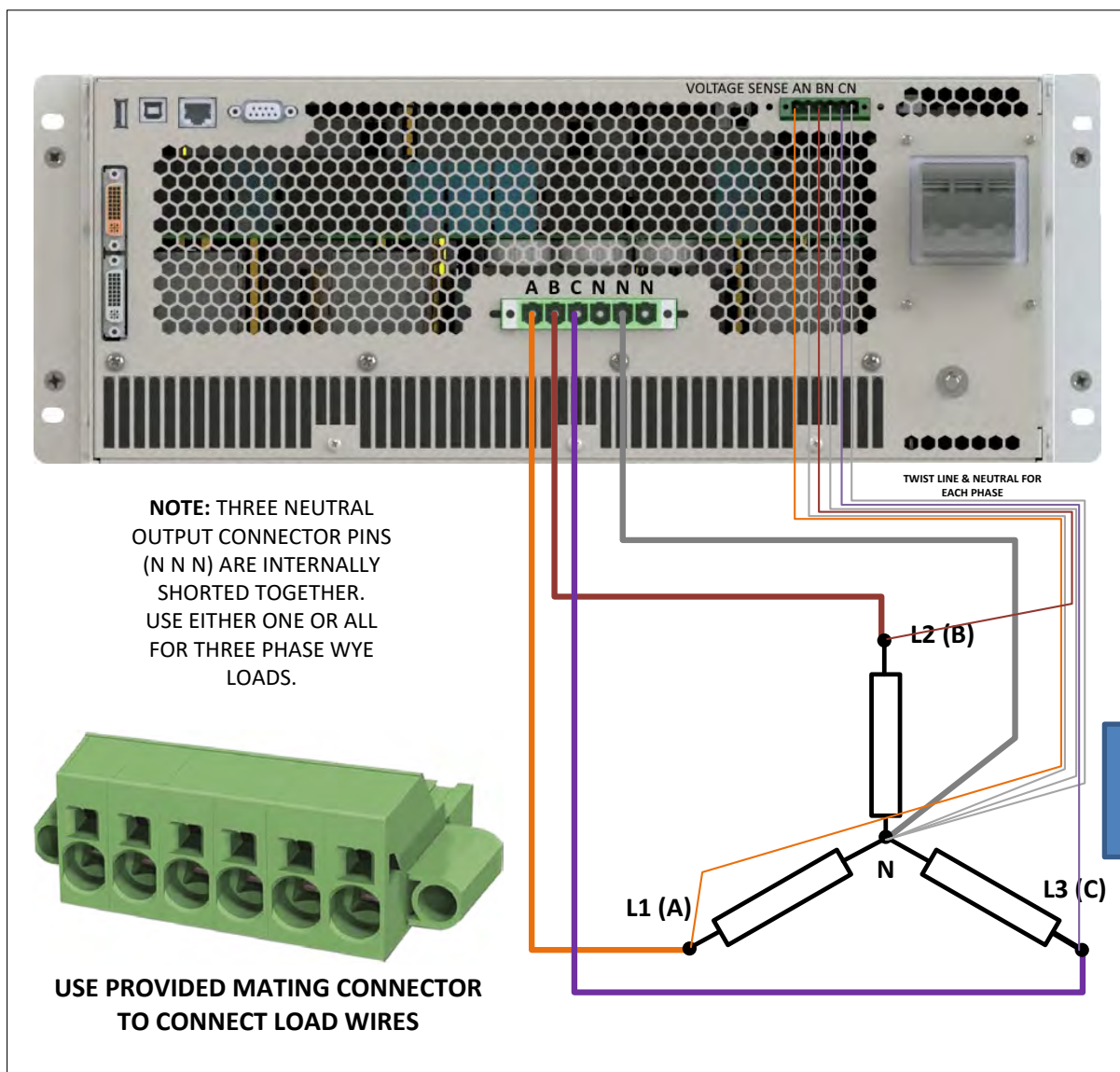

Figure 5-9: Three phase Wye or Split phase Load Output Connections – External Voltage Sense

5.14.3 Three Phase Delta Load Output Connection

Connection of a three-phase load requires the mating connector provided in the AFX Series® ship kit. This six-pole connector uses a spring loaded wire attachment system. To unlock a position, use a small screwdriver or pin to push down in the square hole located directly above each connection. Once you push in, you will feel to spring unlatch. Now push the stripped wire end into the connector and pull out the small screwdriver or pin. This will release the spring locking down the wire. Use a pull test to make sure the wire is clamped down securely.

Note Load and sense wiring are **NOT** included with the power source and must be supplied by the end-user.



Note: The output terminal diameter is 16 mm² so largest wire gauge that can be used is AWG6.

AWG	Diameter		Turns of wire, without insulation		Area	
	(in)	(mm)	(per in)	(per cm)	(kcmil)	(mm ²)
6	0.1620	4.115	6.17	2.43	26.3	13.3

Repeat for the three phase wires. For Delta loads, there is no neutral connection.

The requisite DELTA load output wiring is shown in Figure 5-10 using internal voltage sense and Figure 5-11 when using external voltage sense.

Note Load and sense wiring are **NOT** included with the power source and must be supplied by the end-user.

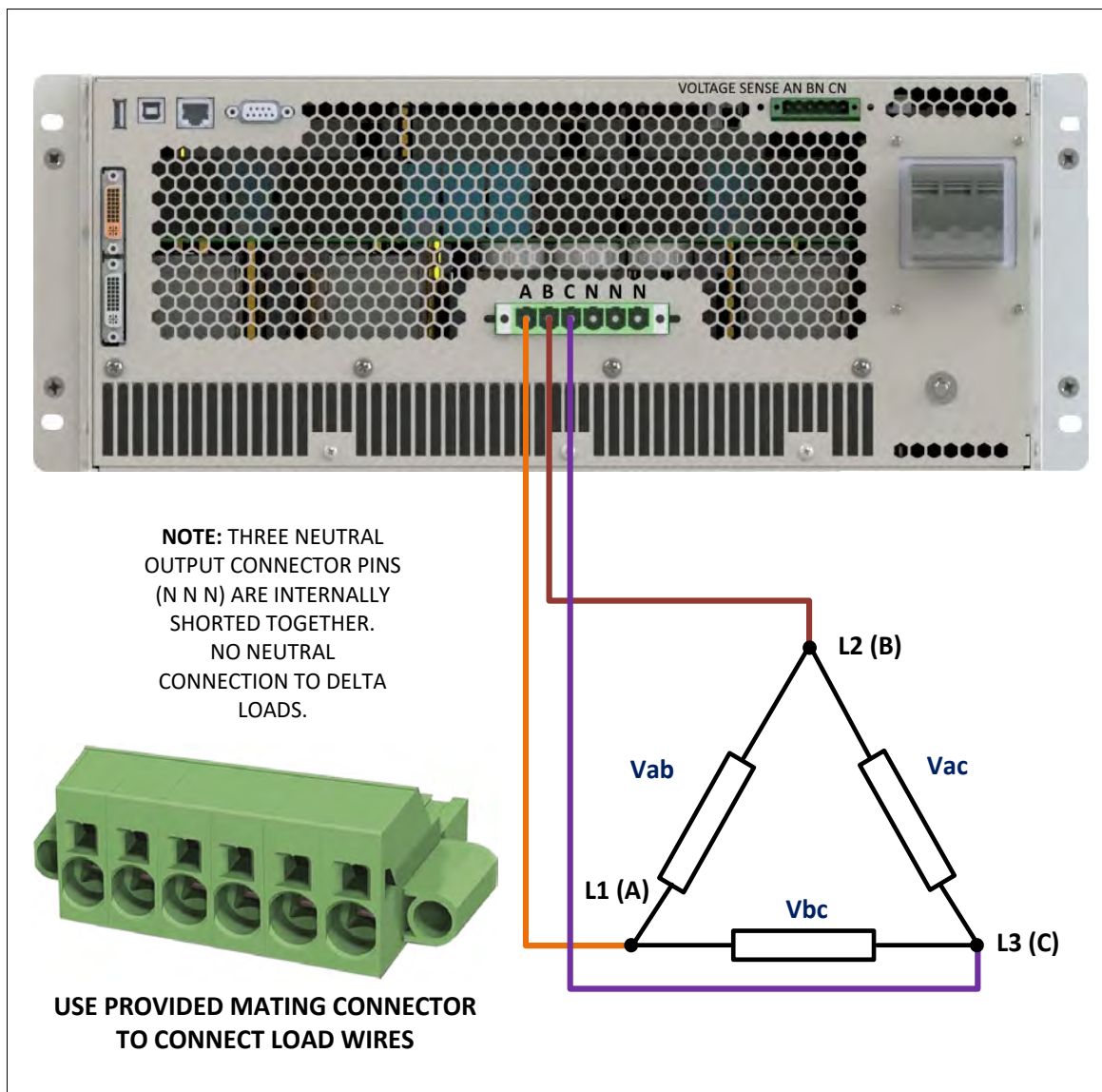

Figure 5-10: Three phase Delta Load Output Connections – Internal Voltage Sense

Note Load and sense wiring are **NOT** included with the power source and must be supplied by the end-user.

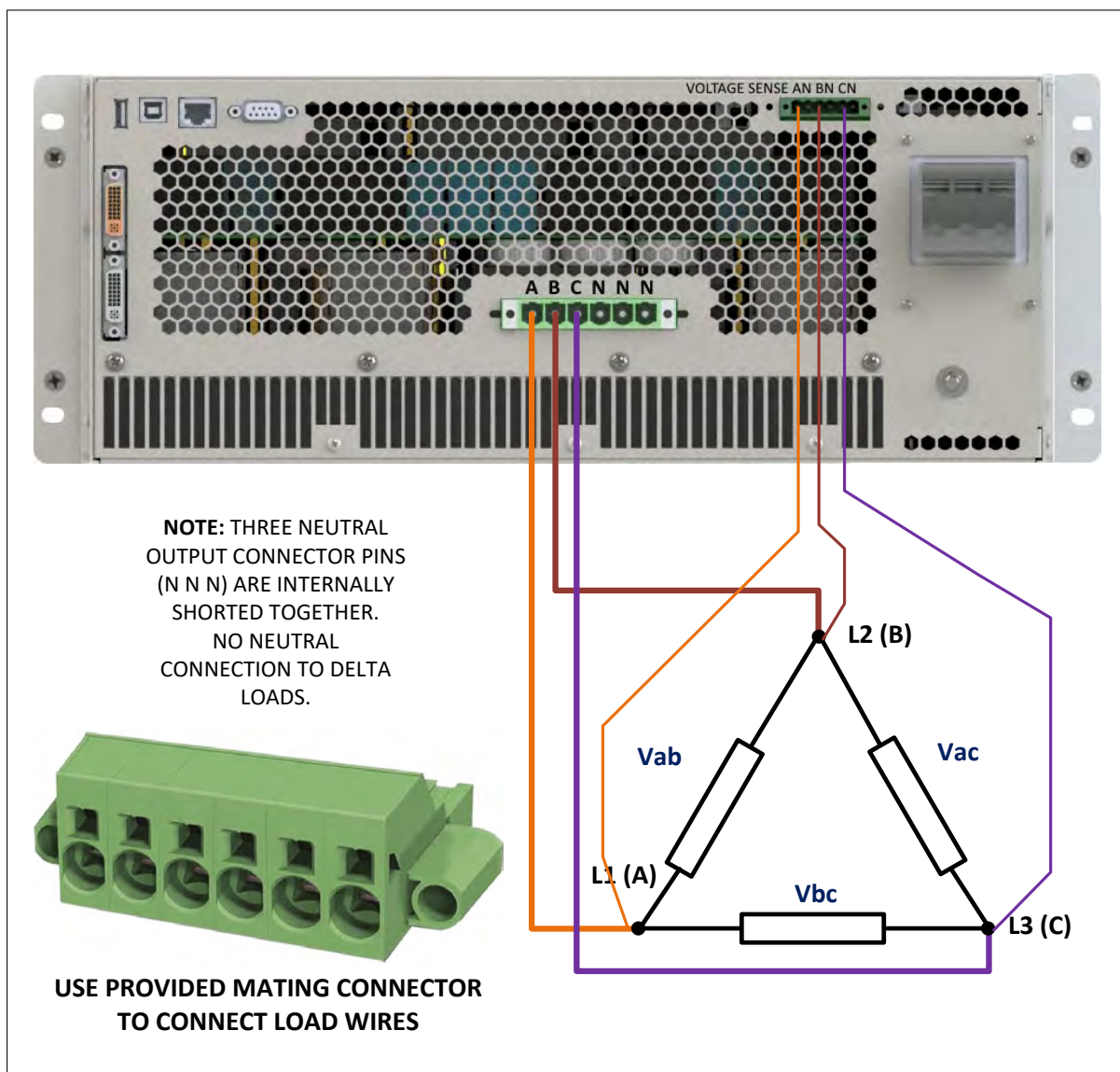

Figure 5-11: Three phase Delta Load Output Connections – External Voltage Sense

5.14.4 AFXS Series & AFX with Option W Output Load Connections

The AFXS & AFX with Option W models differ from a standard AFX in that it has three separated isolated neutral on the output connector instead of three common neutrals. This allows an AFXS power source to be connected in series with a standard AFX master or auxiliary unit.

Note: Standard AFX models can **NOT** be field retrofitted to an AFXS or AFX-W model.



See section 4.16, “Series Output Voltage Range (S Option)” on page 49 for more information on series operation.

5.14.5 Single Phase Load Output Connection

Connection of a single phase or DC load can be accomplished by using the three-phase mating connector provided in the AFX Series® ship kit. This requires shorting of the three phases or DC outputs. A power splicer terminal block like the one shown here may be used. Example of suitable splicer block is Marathon P/N 1322570, 600V, 175A.



Note Junction terminal blocks like the one shown above are **NOT** included with the power source and must be supplied by the end-user.

Alternatively, the optionally available AFX Single Phase Shorting Adaptor may be used - **except on AFXS Series mode AFX models or AFX models with W option.**

This single phase output connector P/N 160086. Not included in AFX Series® ship kit but available through customer service.



Figure 5-12: Optional AFX Single Phase Shorting Adaptor assembly

Connect phase A+B+C output to the Line connection of the AC load or DC+ side for a DC load. Connect all three-phase output connections to the Neutral connection of the AC load or the DC- side for a DC load. Refer to Figure 5-13 for single-phase mode load connection diagram.

Note Load and sense wiring are **NOT** included with the power source and must be supplied by the end-user.

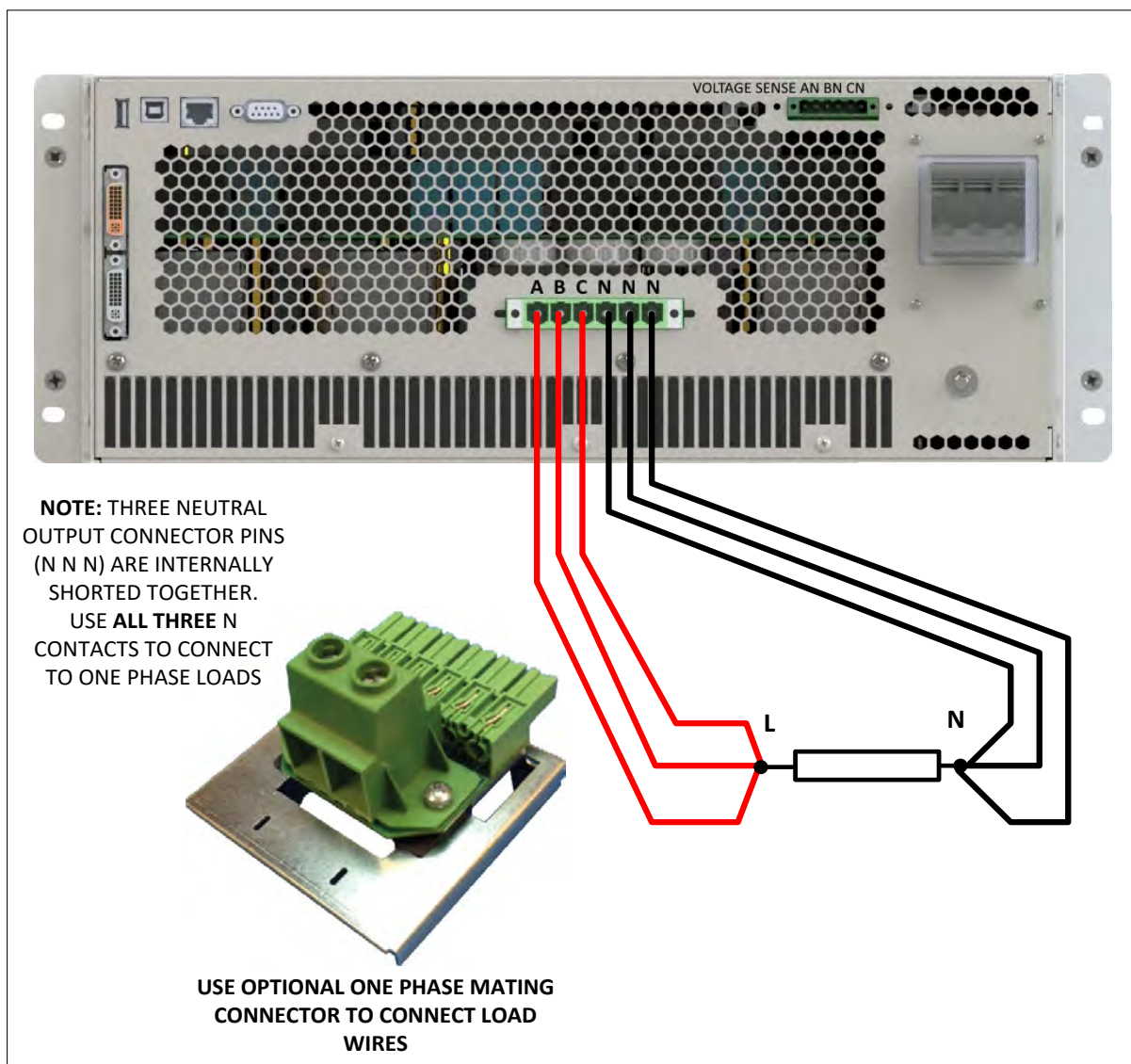

Figure 5-13: Single phase Load Output Connections

5.14.6 External Voltage Sense Connections

**CAUTION**

HAZARDOUS OUTPUT: The power source output may be set to hazardous voltage levels. It provides basic isolation from the ac input mains. Therefore, the external voltage sense must also always be considered hazardous. Connections must be inaccessible to operator in all situations when ac input mains voltage is applied.

Always disconnect power supply from the mains before connecting or disconnecting to the hazardous external voltage sense terminals.

Note Load and sense wiring are **NOT** included with the power source and must be supplied by the end-user.

**AVERTISSEMENT**

SORTIE DANGEREUSE: La sortie de l'appareil peut être réglée à des niveaux de tension dangereux. L'appareil fournit une isolation de base du réseau d'entrée AC. Par conséquent, les connexions de sense externes doivent toujours être considérées comme dangereuses. Les connexions doivent être inaccessibles à l'opérateur dans toutes les situations où la tension d'entrée secteur est appliquée.

Toujours débrancher l'alimentation secteur avant de connecter ou déconnecter les bornes de connexions de sense externes.

**TRANSFORMER OPTION**

AFX Power Sources configured for use with the optional Transformer Option (T-Option) are marked as AFXT-xA on the type label **MUST ALWAYS HAVE** the external voltage sense connected to either the load or the output terminal. These models **DO NOT** have internal voltage sense connections.

**TRANSFORMER OPTION**

Les sources d'alimentation AFX configurées pour être utilisées avec l'option de transformateur en option (option T) sont marquées comme AFXT-xA sur l'étiquette de type **DOIT TOUJOURS** avoir le sens de tension externe connecté à la charge ou à la borne de sortie. Ces modèles **N'ONT PAS** de connexions de détection de tension internes.

When using external voltage sense, sense wires must be connected between the rear panel External voltage sense terminal and the load. These wires do not carry any load current so can be sized accordingly.

Note: If the external sense connections are not used, the power source will use the local (internal) sense points at the output terminals instead to sense the output voltage. This means the sensed voltage may be higher than the voltage at the load as load wire voltage drops is not compensated when using internal sense.

Note: For AFXT Models, the sense connector is normally connected to the Transformer Option chassis. In this case, the external sense connection is made rear panel of the Transformer option chassis. If the Transformer chassis is not present, the External Voltage sense inputs on the rear panel of the AFXT power source **MUST be connected** to either the output terminal or the load **at all times** or an open sense fault will occur.

Note: AFX-2L and AFX-4L Model Units (**L version**) are shipped with the mating External Voltage Sense connector installed and screwed in place to act as a safety cover. When the external voltage sense connection is not used, this connector should be left in place.

AFX(T)-2AG and AFX(T)-4AG Model units (**AG version**) use a Push-in spring connection type external voltage sense terminal that requires no mating connector. Use a small screwdriver⁴ to push in the locking mechanism, push in the stripped sense wire ends and pull out the screwdriver to lock the wire in place. See for reference.

Figure 5-14:
AFX A

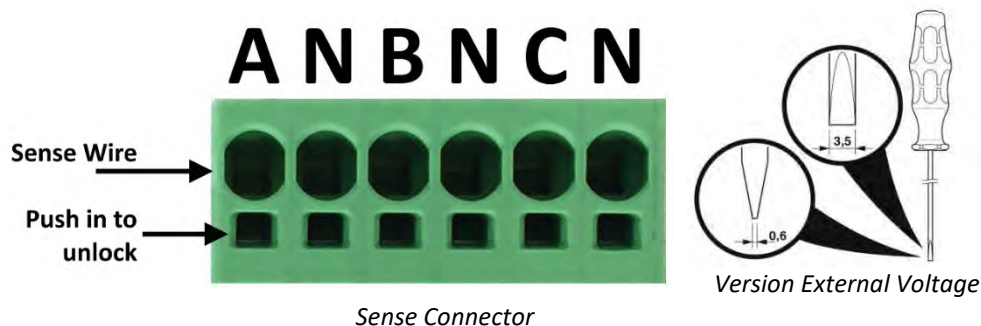

For three-phase sense connection wiring, refer to Figure 5-9 for 3 phase WYE load connections and Figure 5-11 for three phase DELTA load connections.

Note Load and sense wiring are **NOT** included with the power source and must be supplied by the end-user.

Note It is highly recommended to twist each phase and neutral sense wire and connect each neutral as the Vsense input neutrals are **not** shorted on the sense connector.

⁴ Actuation tool, bladed screwdriver, size: 0.6 x 3.5 x 100 mm

5.14.7 Powering Up

The following procedure should be followed before applying mains power:

1. Check that the front panel circuit breaker is in the OFF (O) position.
2. Verify that the model nameplate AC input specification match the local utility power.
3. Make sure that nothing is connected to any of the OUTPUT terminals on the rear panel.
4. Connect the correct AC mains line to the AFX Series® AC input terminal using a suitable three phase AC mains disconnect switch.
5. Close the AC mains disconnect to apply utility power.
6. Turn on the front panel circuit breaker by pulling the lever upward to the “I” position.
Note: Allow about 3 to 5 seconds for the AFX unit to fully initialize.
7. If the instrument does not turn on for some reason, turn OFF the front panel circuit breaker and verify the presence of the correct AC line input voltage using appropriate safety measures.

Note: For information on turning on AFX cabinet systems, refer to Section 5.16, “AFX Cabinet Systems Turn ON and Turn OFF Procedures” instead.

5.14.8 In Case of Malfunction

In the unlikely event of an instrument malfunction or if the instrument does not turn on despite the presence of the correct AC line voltage, please attach a warning tag to the instrument to identify the owner and indicate that service or repair is required. Contact Pacific Power Source or its authorized representative to arrange for service.

5.15 Cabinet Systems Installation

AFX Series® power sources above 15kVA output are available pre-installed and pre-wired in a 19-inch cabinet. These cabinet systems include all internal AC input and AC or DC output wiring. Several options can be added to these AFX cabinet systems as well.

Note AC input, AC Load and sense wiring are **NOT** included with the power source Cabinet and must be supplied by the end-user. Only internal cabinet wiring and terminal blocks are included.

5.15.1 Standard Cabinet Sizes

All standard AFX cabinet systems feature the same depth and width but height may vary by power level to accommodate more or less AFX units.

The following two sizes are currently offered.

- 15U For power levels of 18kVA, 24kVA, 30kVA or 45kVA
- 28U For power levels of 60kVA and higher

Note that alternative cabinet sizes and power levels may be supported for special requirements so this information applies to catalog models only.

Refer to cabinet dimension drawings shown below for the two available cabinet dimensions.

5.15.2 Tools Required

Installing AC Input and AC/DC Output cable connections to the terminal blocks furnished with AFX cabinet systems requires the use of a Phillips screwdriver to remove the rear panel screen and some Allen (Hex) wrenches for the terminal blocks.



#2 x 6 Phillips Screw driver. Not included in AFX Cabinet ship kit.



Allen Wrenches, 3/16" and 5/16" Size (SAE, non-metric). Included in AFX Cabinet ship kit.

5.15.3 Dimensions

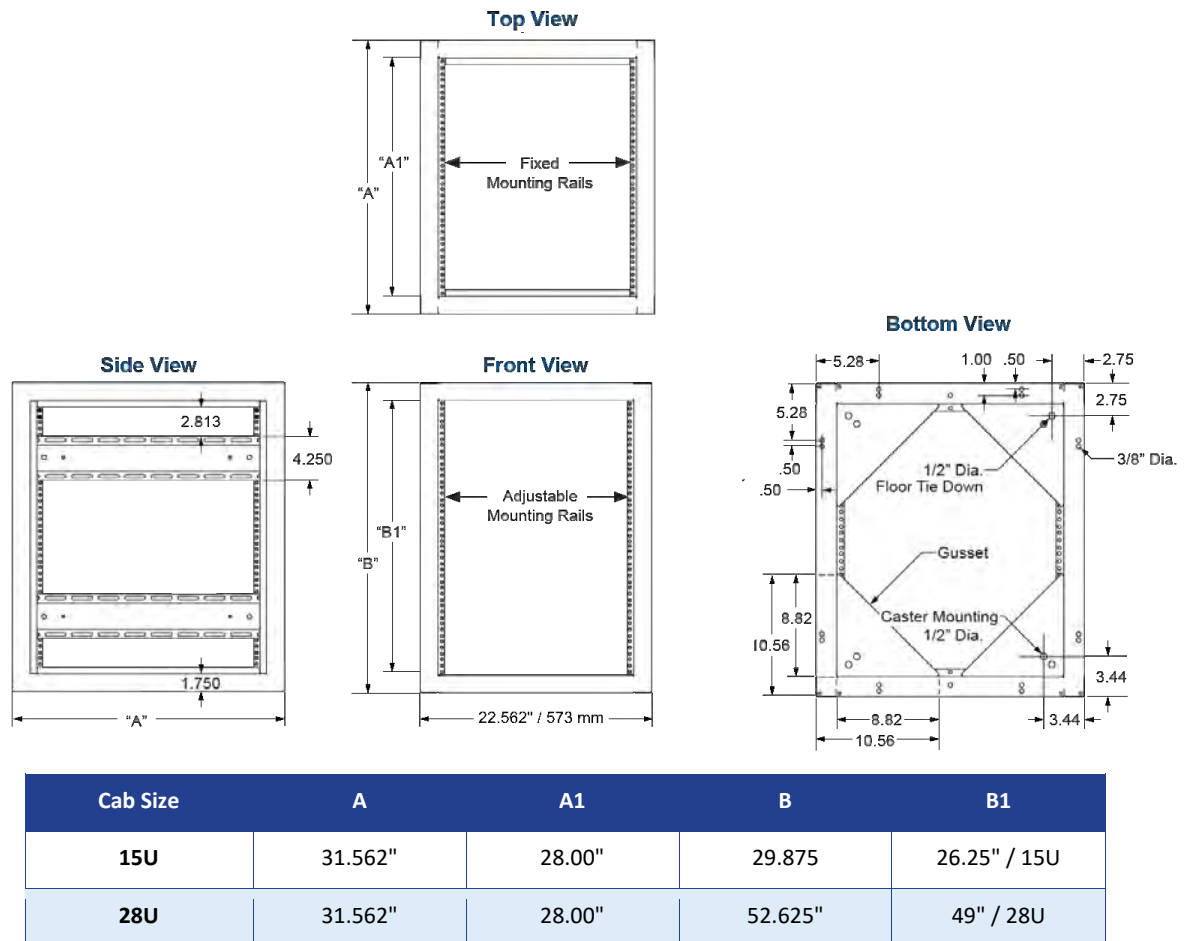

Figure 5-15: AFX Cabinet Dimensions

5.15.4 Cabinet System AC Input Connections



All input and output connections are located at the lower rear of the back of the cabinet. To access the internal terminal blocks, the rear panel grid must be removed temporarily by removing the screws that hold it to the cabinet's rear. Strain reliefs for both input and output cables are provided on the lower rear filler panel.

Note: Input and /or Output cables for grid power and load connections are **NOT** included with AFX cabinets.

AC input ratings for Cabinet systems are the same as for individual AFX units. The AC input rating is listed on the cabinet serial tag, which is located on the side of the cabinet. As sample AFX Cabinet System label is shown below. Maximum AC input current rating is shown per phase for the entire cabinet at low line conditions.

Note: The grid panel **MUST** be re-installed after all input and output wiring is installed.

INPUT VOLTAGE RATING ON SYSTEM LABEL

AFX SERIES CABINET SYSTEM DATA				AC INPUT VOLTAGE	
MODEL	3450AFX-4L			VOLTAGE	380 Vac-480 Vac, 3~
S/N	_____	CABINET	1 OF 1	AMPS MAX	90 A FREQ 47 - 63 Hz
IWA	_____	W/O	_____		
MOD	_____	CAB. SIZE	27U		
UNIT#	MODEL	TYPE	S/N	 PATENTS PENDING PACIFIC POWER SOURCE, INC., CA 	
1	3150AFX-4L	MASTER	105564002		
2	3150AFX-4NC	AUX	105684004		
3	3150AFX-4NC	AUX	105624005		
4	_____	_____	_____		



CAUTION: GRID DISCONNECT REQUIRED

Note that a suitable grid power disconnect switch must be provided between the grid connection and the AFX Cabinet AC input terminal block. Consult an electrician to ensure proper local electrical codes are used at all times.

5.15.5 Recommended AC Input Wire Strip Lengths

The following wire strip lengths are required for the AC input wires listed.

- L1, L2, L3 Wires: 11/16", 17 mm
- Neutral, Ground Wires: 3/4", 19 mm

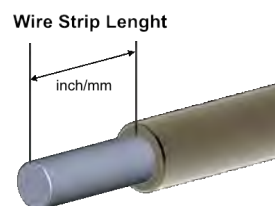

Note AC input, AC Load and sense wiring are **NOT** included with the power source Cabinet and must be supplied by the end-user. Only internal cabinet wiring and terminal blocks are included.

Connect AC power as shown in the diagram below.

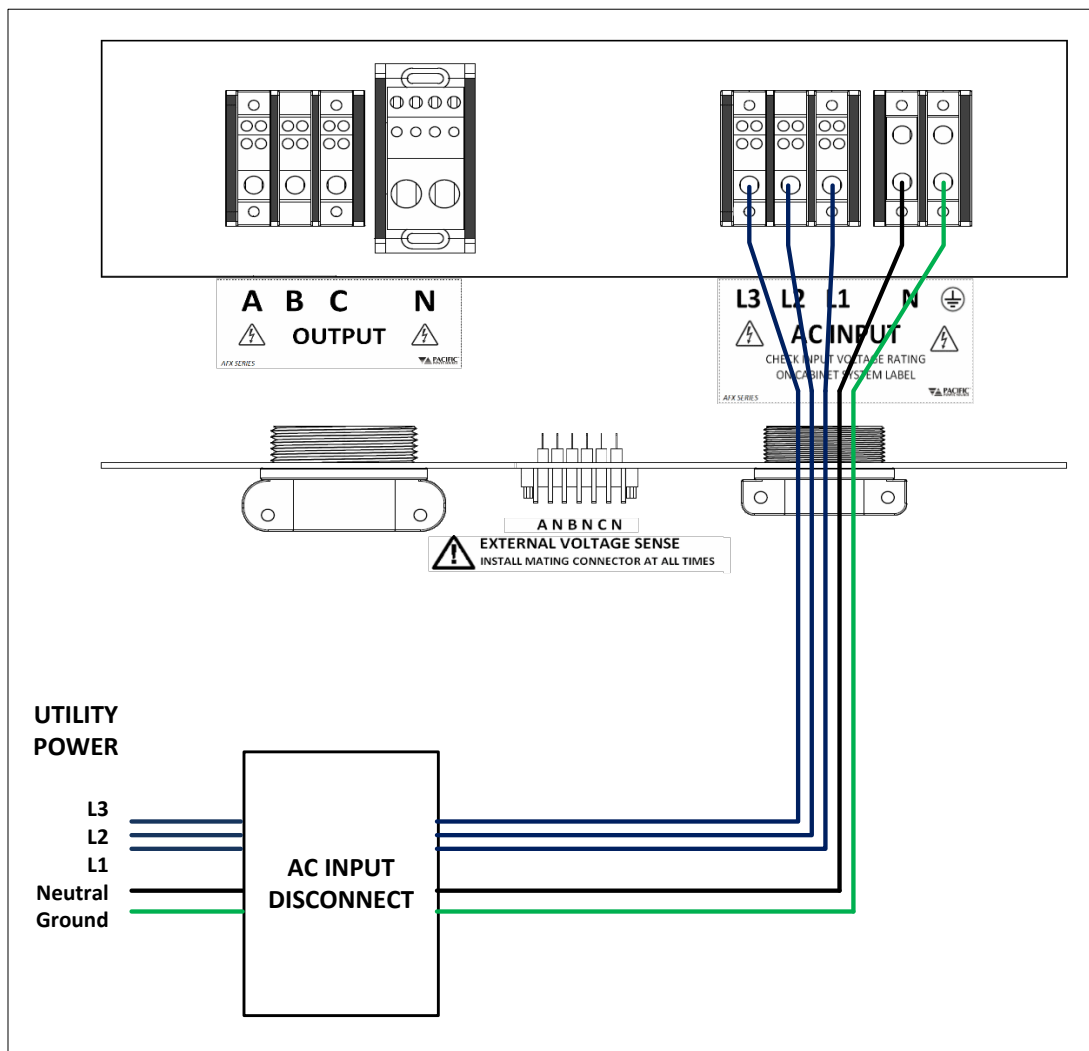

Figure 5-16: AFX Cabinet AC Input Connection Diagram

5.15.6 Cabinet System AC Input Neutral

The AFX power sources DO NOT require a neutral connection as they operate from a Delta AC input of either 208V L-L or 380 to 480V L-L. However, some available cabinet options may operate from Line to Neutral input voltage only. If so, a neutral must be brought into the cabinet (Wye). Refer to Section 5.17, “Cabinet System Options” for more details.

5.15.7 Cabinet System Grounding

All AFX cabinet systems MUST be properly grounded using the provided GROUND terminal on the AC Input terminal block located inside the cabinet.



SAFETY NOTICE: GROUNDING

This product is a Safety Class 1 instrument (provided with a protective earth terminal). To minimize shock hazard, the instrument chassis or cabinet must be connected to an electrical safety ground. The instrument must be connected to the AC power supply mains through a properly rated three-phase power cable with protective earth (L1-L2-L3-E). Any interruption of the protective (grounding) conductor or disconnection of the protective earth terminal will cause a potential shock hazard that could result in personal injury.

This instrument may be equipped with a line filter to reduce electromagnetic interference and must be properly grounded to minimize electric shock hazard. Operation at line voltages or frequencies in excess of those stated on the model type plate may cause leakage currents in excess of 5.0 mA peak.



REGLE DE SECURITE: MISE A LA TERRE

Ce produit est un équipement de Classe 1 (muni d'une borne de mise à la terre). Pour minimiser le risque de choc électrique, le châssis de l'appareil ou de l'armoire/rack doit impérativement être relié à une terre de sécurité électrique. L'appareil doit être branché sur le secteur d'alimentation électrique à courant alternatif par un câble d'alimentation triphasé approprié avec terre de protection (L1-L2-L3-PE). Toute interruption de la mise à la terre de protection ou de déconnexion de la borne de terre causera un risque de choc électrique qui pourrait entraîner des blessures.

Cet appareil peut être équipé d'un filtre secteur pour réduire les interférences électromagnétiques et doit être correctement mis à la terre afin de minimiser le risque de choc électrique. Le fonctionnement sous tensions et fréquences supérieures à celles indiquées sur l'étiquette peut provoquer des courants de fuite de plus de 5,0 mA peak.

5.15.8 Recommended AC Output Wire Strip Lengths

The following wire strip lengths are required for the output wires listed.

Phase A, B & C Wires:	11/16", 17 mm
Neutral Wire:	1 9/16", 40 mm

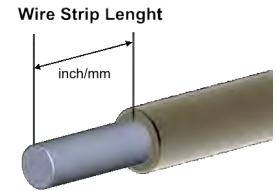

Note AC input, AC Load and sense wiring are **NOT** included with the power source Cabinet and must be supplied by the end-user. Only internal cabinet wiring and terminal blocks are included.

5.15.9 Cabinet Load Connections – Three Phase WYE Loads

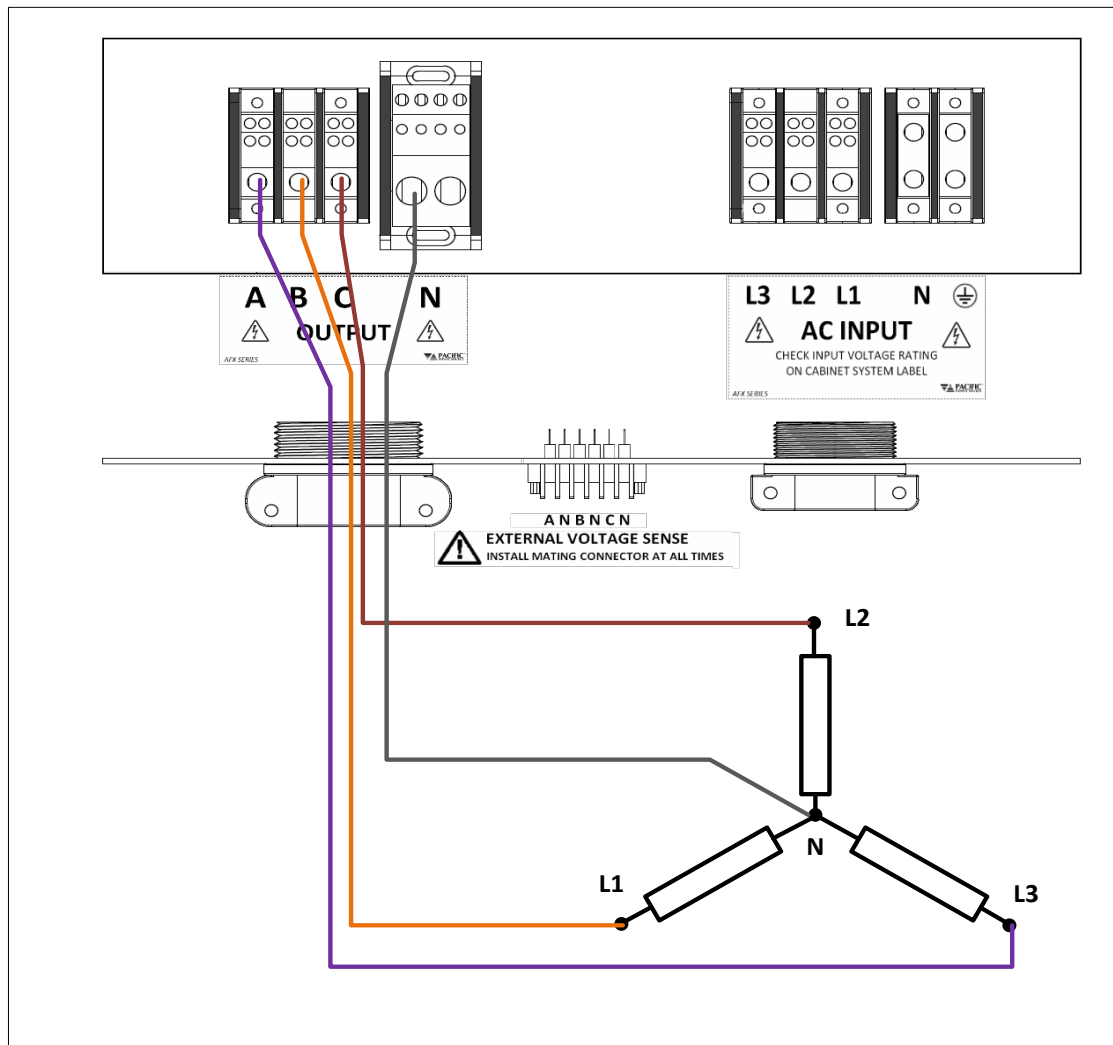

Figure 5-17: WYE Load Connection Diagram

5.15.10 Cabinet Load Connections – Three Phase Delta Loads

Note AC input, AC Load and sense wiring are **NOT** included with the power source Cabinet and must be supplied by the end-user. Only internal cabinet wiring and terminal blocks are included.

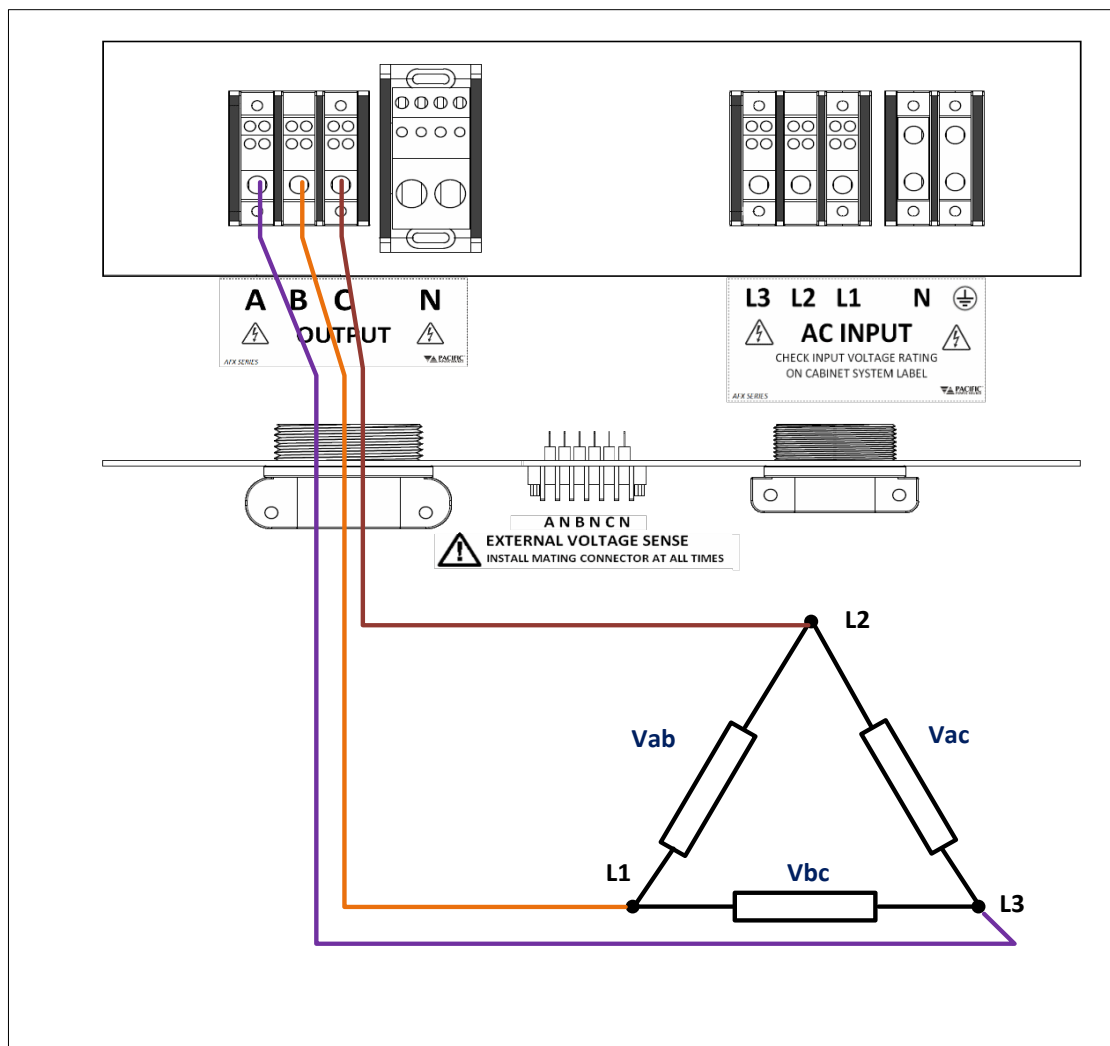

Figure 5-18: Delta Load Connection Diagram

5.15.11 Cabinet Load Connections – Single Phase Loads

Note AC input, AC Load and sense wiring are **NOT** included with the power source Cabinet and must be supplied by the end-user. Only internal cabinet wiring and terminal blocks are included.

Note that the Neutral connection for single-phase loads will have to carry all the line current so the wire size must be chosen accordingly. Since AFX cabinets come standard with a three-phase output terminal block, the three output terminals A, B and C must be shorted together, either at the load or at the output terminal block as shown in the diagram below.

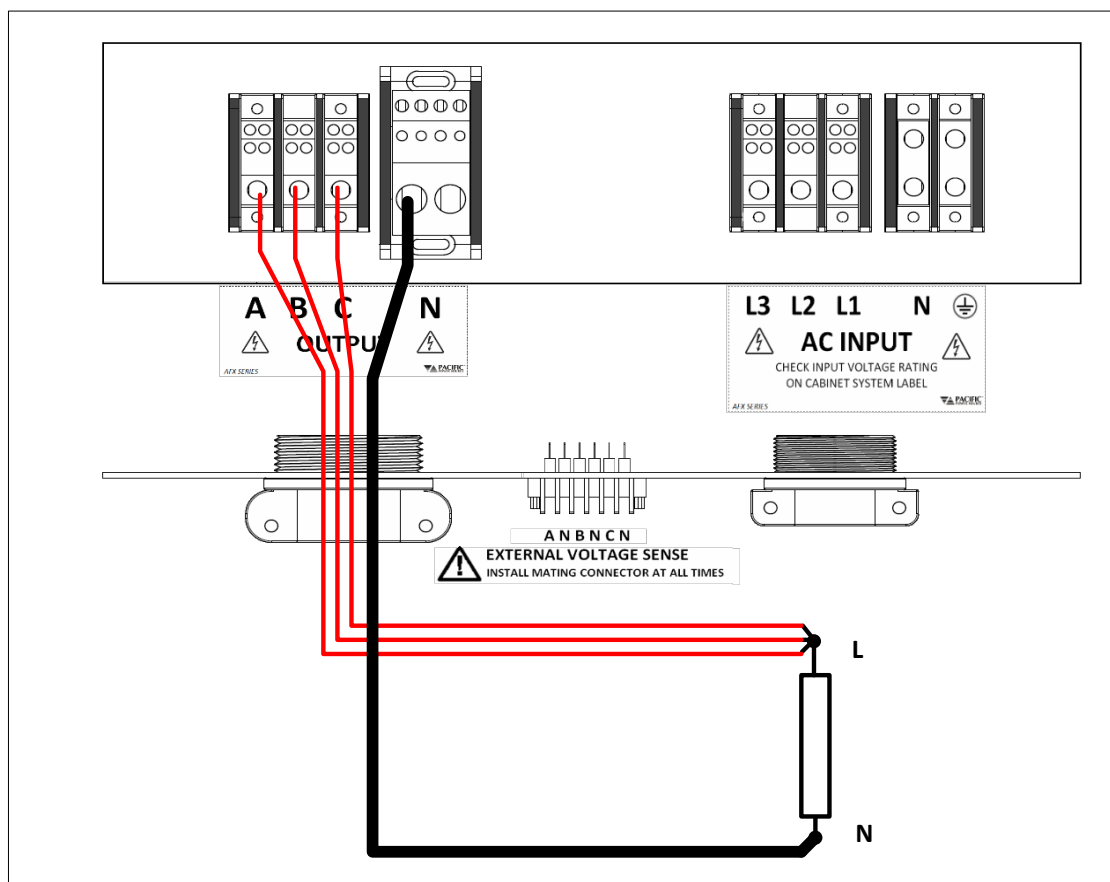

Figure 5-19: Single Phase Load Connection Diagram

5.16 AFX Cabinet Systems Turn ON and Turn OFF Procedures

AFX Cabinet systems can be turned on or off using the front panel mounted circuit breakers on the master and auxiliary units. Turn On and Turn Off sequence recommendations are listed below and illustrated in Figure 5-20. The sequence is not critical as long as units are turned on within 15 seconds of each other. If more time elapses, an error may be displayed and the master/aux discovery process should be restarted from the PARALLEL UNITS screen in the SYSTEM menu. Refer to section 6.8.7, “PARALLEL UNITS Screen”.

Alternatively, the master grid power disconnect switch that is required for cabinet installation can be used to connect or disconnect all units from grid power at the same time.

5.16.1 Cabinet Power Turn ON using Circuit Breakers

The following turn on sequence is recommended:

1. Turn **ON** bottom auxiliary unit **first** by pulling its front panel circuit lever to the upward (ON) position.
2. Turn **ON** any additional auxiliary units between the bottom auxiliary unit and the top Master unit by pulling each front panel circuit lever to the upward (ON) position.
3. Turn **ON** the Master unit **last** by pulling its front panel circuit lever to the upward (ON) position.

This will ensure all auxiliary units are up and will be found when the master starts the discovery process.

5.16.2 Cabinet Power Turn OFF using Circuit Breakers

The turn off procedures is the reverse of the turn on one as follows:

1. First, turn **OFF** AFX System output using the OUTPUT button on the Master unit front panel first to make sure any load is powered down first.
2. Then, turn **OFF** the Master unit **first** by flipping its front panel circuit lever to the down (OFF) position.
3. Turn **OFF** the first auxiliary unit located below the master unit by flipping the front panel circuit lever to the down (OFF) position.
4. Turn **OFF** the bottom auxiliary unit **last** by flipping its front panel circuit lever to the down (OFF) position.

Note: Turning off all AFX units in a cabinet DOES NOT remove MAINS power from it. If any service is to be performed on the cabinet, make sure the MAINS power (grid power) is disconnected first.

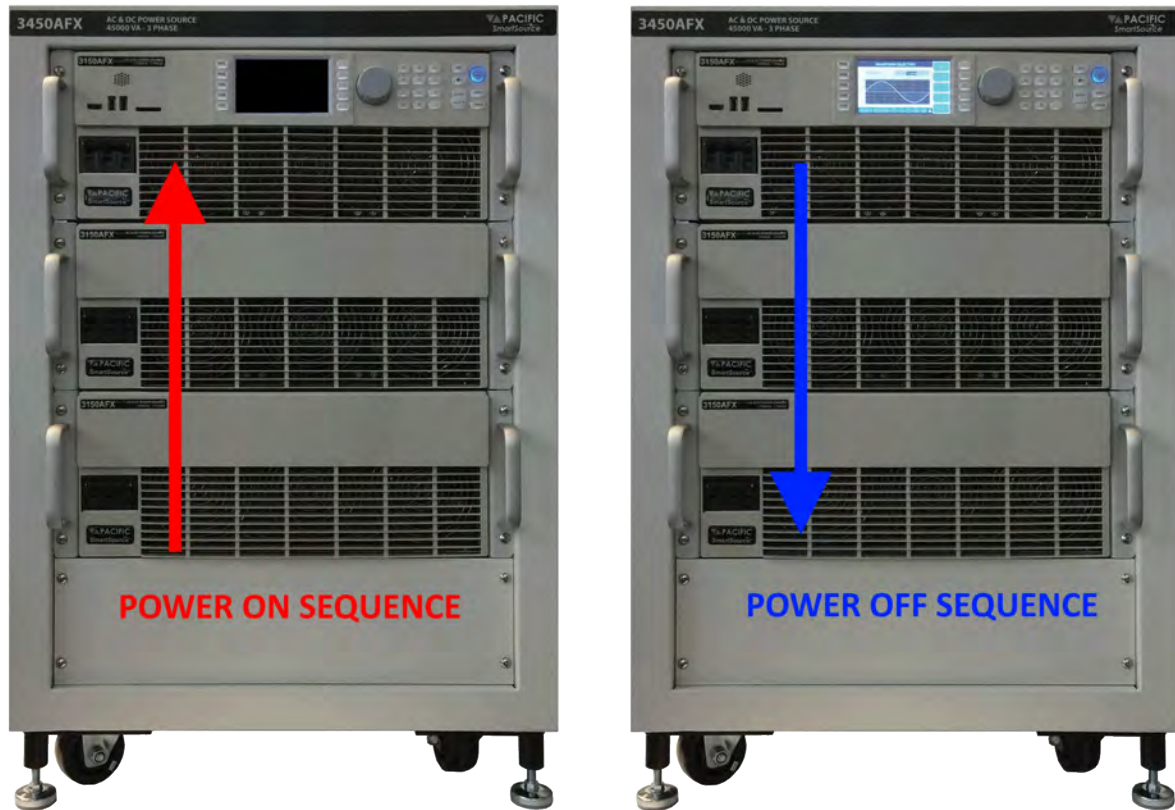

Figure 5-20: AFX Cabinet System Power ON and OFF Sequences

5.17 Cabinet System Options

The following cabinet options are available.

Option	Description	Available on
-OCS	Output Control Switch	All AFX cabinets
-EPO	Emergency Power Off	
-MRC	Mode Relay Control	
-27UX1	Expandable 3300AFX cabinet, prepped for one additional aux unit	3180AFX, 3240AFX & 3300AFX
-27UX2	Expandable 3300AFX cabinet, prepped for two additional aux units	

Table 5-2: Available AFX Cabinet Options

Following sections cover operation or use of these available options. If your cabinet was not furnished with these options, you skip to Section 5.18, "Interface Options".

5.17.1 -OCS: Output Control Switch Option

The output control switch option adds an output control selector switch on a 1U filler panel located directly below the master AFX unit of the cabinet. It also provides a terminal block located in the rear of the AFX cabinet that allows the user to wire in one or more series SPST switches as part of a text fixture safety interlock. Opening the front panel mounted switch will disable the output of the power source. The ON and OFF position of the OCS switch is silkscreened on the panel.



5.17.1.1 OCS Switch wiring for "A" Versions

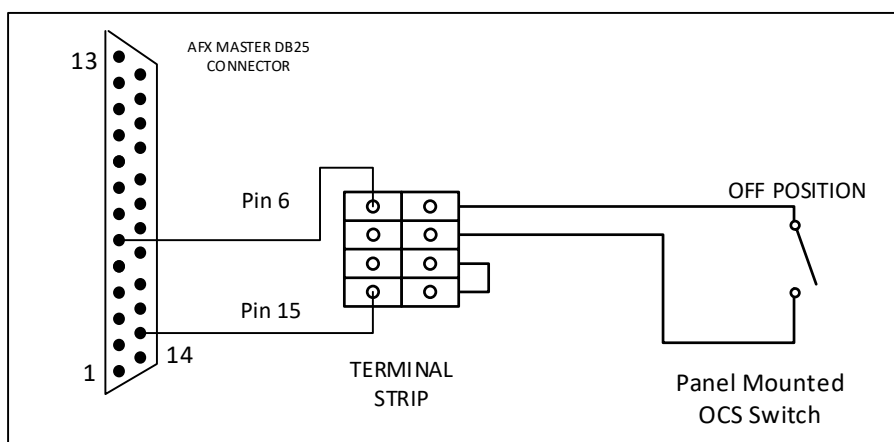

Figure 5-21AFX "AG" Version Cabinet -OCS Option Wiring Diagram

5.17.1.2 OCS Switch wiring for "L" Versions

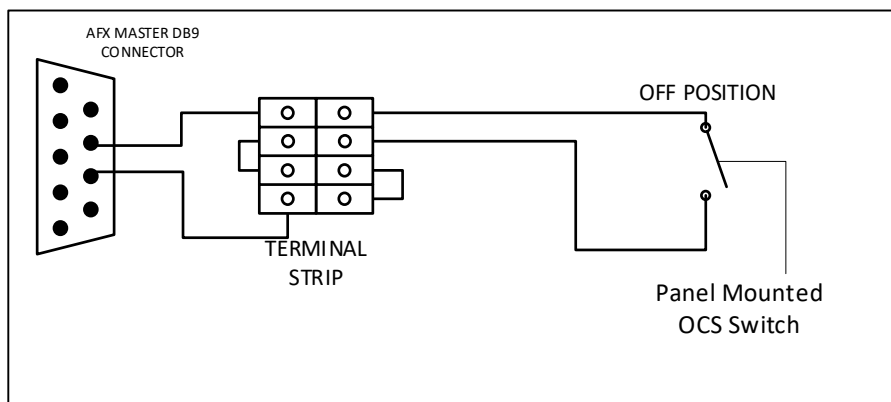

Figure 5-22: AFX "L" Version Cabinet -OCS Option Wiring Diagram

With this option installed, the Remote Inhibit function of the AFX master unit is permanently set to **REMOTE INHIBIT**. (Refer to Section 5.18.7 on page 98).

Note: For 45kVA systems, a taller cabinet will be required to accommodate the 1U panel for the Output Control switch or a remote switch may be used instead.

5.17.2 -EPO: Emergency Power Off Option

The Emergency Power Off option adds a mains input contactor to the cabinet system. This contactor is normally closed allowing the AFX system to power up. A mushroom style emergency OFF push button is located on a 1U panel directly below the master unit in the cabinet. When pushed, the AC power input contactor opens, removing AC input power from all AFX units installed in the cabinet. The Mushroom switch must be twisted and pulled out in order to re-connect input power.



Note: For 45kVA systems, a taller cabinet will be required to accommodate the 1U panel for the Emergency Off Mushroom switch.

5.17.3 -MRC: Mode Relay Control Option

The Mode Relay Control option adds contactors to the bottom of the cabinet that are controlled by the master AFX unit to short the three output phases together when the AFX system is placed in single phase output mode. This eliminates the need to manually short and separate output phase connections when toggling between single and multi-phase modes of operation.

5.17.4 -28UX Option

The 28UX option uses a taller than normal cabinet to allow for future expansion. Wiring for additional AFX units is already installed in AFX cabinets ordered with these options. This

option applies to standard 15U based AFX cabinet models only and substitutes a 28U cabinet with additional filler panels.

5.17.5 -Transformer Options for Cabinet Systems

Cabinet systems can be ordered with an optional AC only voltage range higher than 300Vac. Standard transformer coupled range is 400Vac L-N / 692V L-L. Other voltage range may be available on request.

Cabinet based transformer option systems have three step-up transformers installed at the bottom of the cabinet. As such, cabinet height may be taller than for the equivalent power rated AFX cabinet without the transformer option.

All controls and wiring between the AFX power sources and the optional transformers is installed inside the cabinet and operation is no different from a standard AFX cabinet system except there is another available AC only voltage range.

Refer to Section 6.4 for details on using the optional voltage range.

5.18 Interface Options

All AFX Series® models supports three different remote control interface options; USB, LAN and RS232. AFX -2AG and -4AG models also support an optional GPIB interface.

All remote control interface connectors are located at the rear panel as shown in the illustration below.

5.18.1 Rear Panel Connector Locations - "L" Versions

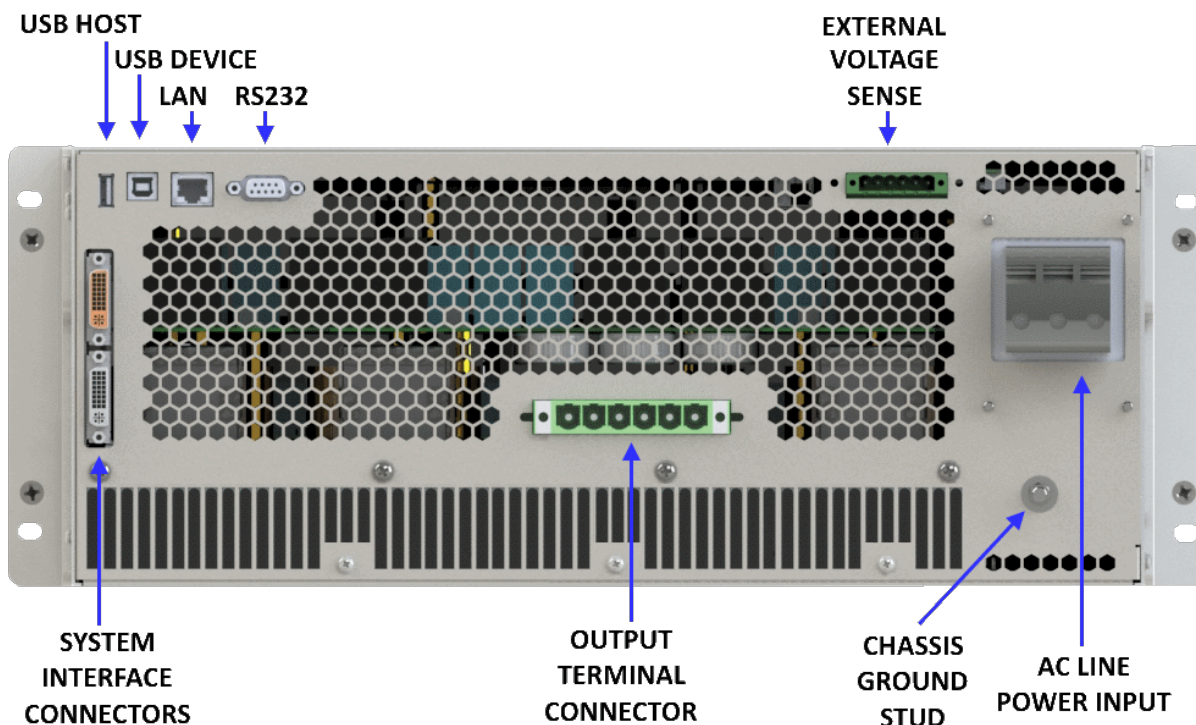

Figure 5-23: Remote Control Interface Connector Locations on Rear Panel (L Versions)



CAUTION



Do NOT connect the RJ45 LAN (Ethernet) connector of the power source to a PoE (Power over Ethernet) port, as the DC voltage will damage the LAN interface.

5.18.2 Rear Panel Connector Locations - "A" Versions

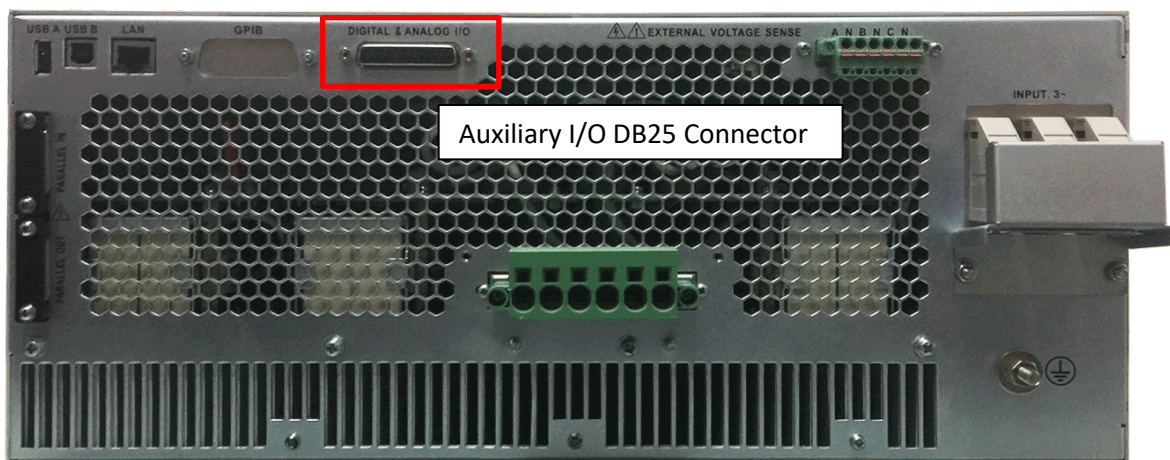

Table 5-3: Remote Control Interface Connector Locations on Rear Panel (A Versions)

5.18.3 Rear Panel Connector Locations - "AG" Versions

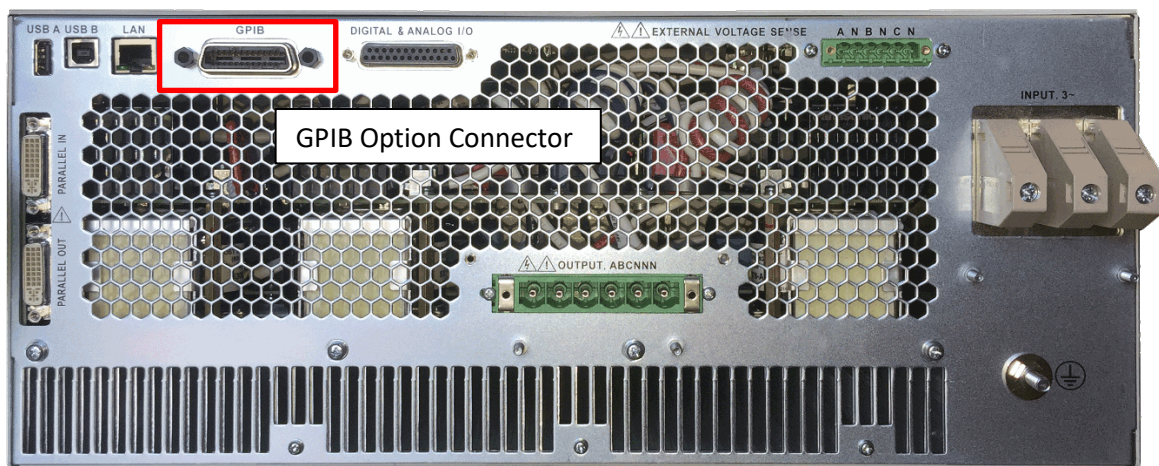

Table 5-4: Remote Control Interface Connector Locations on Rear Panel (A Versions w GPIB)

5.18.4 USB Device Interface

The USB DEVICE interface (USB Type B connector on the rear panel) provides a virtual COM port for the PC. Via this port, the unit can be controlled as a normal RS232 interface, e. g. with a terminal program or user application program. Refer to the section 9, "USB Driver Installation" for further setup and configuration information.

Refer to the section 9, "USB Driver Installation" for further setup and configuration information.

5.18.5 RS232 Serial Interface

5.18.5.1 RS232 Interface and Remote Inhibit Function

On AFX Series models with firmware revision numbers lower than 2.0.13, there is a conflict between the RS232 interface and the Remote Inhibit function. Both cannot be used at the same time. To enable the Remote Inhibit input control line, the RS232 interface must be disabled. This can be done using the browser interface over LAN or USB or from the front panel. If the Remote Inhibit function is needed, use the USB interface instead of RS232.

To disable RS232 from Web browser, select **SYSTEM** Menu -> **INTERFACE SETUP** and move the SERIAL CONFIGURATION ENABLE position to OFF.

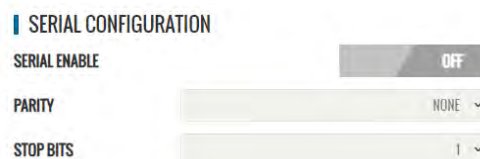

To disable RS232 from the front panel, press the CONFIGURATION key to the left of the LCD, select Interfaces, then select RS232 Interface and set the Status field to **Disabled**. Refer to section 6.8.5.4 on page 182.

Note: For units with firmware revision 2.0.13 or higher, the RS232 interface is automatically disabled when enabling Remote Inhibit.

5.18.5.2 "A" and AG" Versions

The RS232 serial interface on "A" or "AG" versions of the AFX Series is incorporated in the DB25 Auxiliary I/O connector located on the rear panel. Refer to section 4.14, "Auxiliary I/O" on page 44 for details.

PIN	Abbreviation	Description
Pin 1	RXD	RS232 I/F – Receive Data
Pin 2	TXD	Gnd
Pin 14	DTR	RS232 I/F – Transmit Data

Table 5-5: RS232 DB25 Tx and Rx Pin Locations

If only the RS232 interface function is used, a regular straight through DB9 to DB9 cable can be used to connect to a PC serial port.

5.18.5.3 “L” Versions

A DB9 serial interface connector is located on the rear panel for “L” version models of the AFX Series. “A” version models has the serial interface integrated in the Aux I/O DB25 connector instead.

The DB9 connector is also used for the Remote Inhibit input (pins 7 and 9) and Mode Relay control output (pins 8 and 5) functions. These functions can be used while using the serial interface at the same time if needed but a special cable will be required to do so.

PIN	Abbreviation	Description
Pin 1	N/C	Not connected
Pin 2	TXD	Transmit Data
Pin 3	RXD	Receive Data
Pin 4	DTR	Data Terminal Ready
Pin 5	COM	Common
Pin 7	RTS	Input – Remote Inhibit
Pin 8	CTS	Output – Mode Relay Control
Pin 9	N/C	+5Vdc internal pull-up for Remote Inhibit

Table 5-6: Standard RS232 DB9 Pin Assignments

If only the RS232 interface function is used, a regular straight through DB9 to DB9 cable can be used to connect to a PC serial port.

5.18.6 GPIB Device Interface (Option G)

The GPIB interface uses the IEEE488.1 standard 24-pin D-Shell Amphenol micro ribbon connector. Using a standard GPIB cable, the cable will break out to the left of the unit when facing the rear. This will typically obstruct USB and LAN interface connector access. Reverse GPIB cables are available but using these will obstruct the Auxiliary I/O connector.

The GPIB pin assignments are per the IEEE488.1 standard and listed in the table below.

PIN	Signal	Description
Pin 1	DIO1	Data input/output bit.
Pin 2	DIO2	Data input/output bit.
Pin 3	DIO3	Data input/output bit.
Pin 4	DIO4	Data input/output bit.
Pin 5	EOI	End-or-identify.
Pin 6	DAV	Data valid.
Pin 7	NRFD	Not ready for data.
Pin 8	NDAC	Not data accepted.
Pin 9	IFC	Interface clear.
Pin 10	SRQ	Service request.
Pin 11	ATN	Attention.
Pin 12	SHIELD	
Pin 13	DIO5	Data input/output bit.
Pin 14	DIO6	Data input/output bit.
Pin 15	DIO7	Data input/output bit.
Pin 16	DIO8	Data input/output bit.
Pin 17	REN	Remote enable.
Pin 18	GND	(wire twisted with DAV)
Pin 19	GND	(wire twisted with NRFD)
Pin 20	GND	(wire twisted with NDAC)
Pin 21	GND	(wire twisted with IFC)
Pin 22	GND	(wire twisted with SRQ)
Pin 23	GND	(wire twisted with ATN)
Pin 24	Logic ground	

Table 5-7: GPIB Interface Connector Pin Assignments

5.18.7 Remote Inhibit or Enable Input

The remote inhibit may be used to provide output shut down if a rear panel rack door is opened while the output is on. A contact closure between pins 7 and 9 (or an external 5Vdc supply if MODE RELAY CONTROL is enabled) will allow control of the output relay from either the front panel or a remote control interface. . “A” version models have the remote inhibit function on the Aux I/O DB25 connector instead.

There are three modes of operation for this input:

1. **Disable mode:** In his mode, the Remote Inhibit inputs are not active so this function is turned off. No short between the RI pins is required to enable the output in this mode.
2. **Remote Inhibit mode:** The two pins have to be shorted for the output to be enabled from the front panel or remote command. This is a necessary but not a sufficient condition to enable the output. If the output is enabled and the remote inhibit connection is open, a fault is generated. This mode is recommended for interlock safety applications such safety cages and test fixture interlocks.
3. **Remote Enable mode:** The output can be enabled by shorting these two pins, regardless of the output enable command/button. It is a sufficient condition to enable the output.

The mode can be selected from the SYST (SYSTEM) menu screen using the Interfaces, Remote Inhibit selection as shown below.

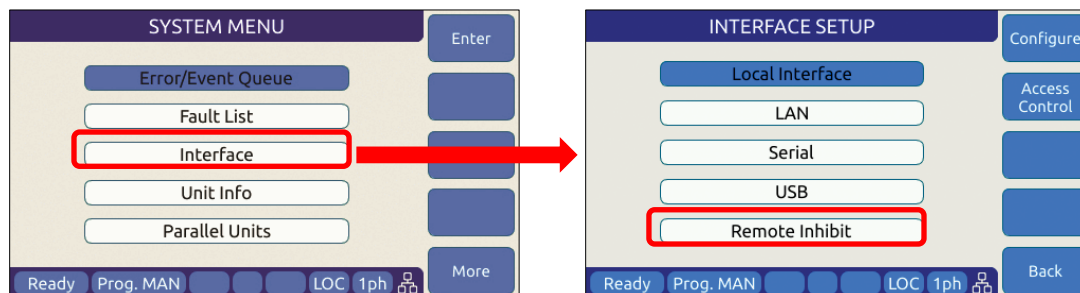

Figure 5-24: Remote Inhibit Control Screen

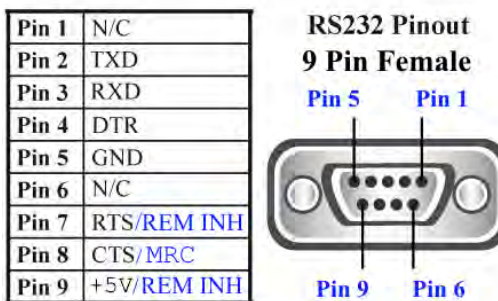
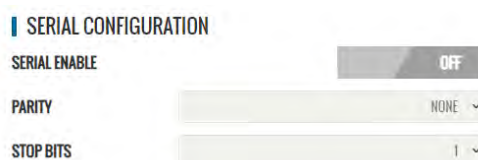

Figure 5-25: Remote Inhibit Pins on DB9 for AFX-2L and AFX-4L Versions

RS232 Interface and Remote Inhibit Function

On AFX Series models with firmware revision numbers lower than 2.0.13, there is a conflict between the RS232 interface and the Remote Inhibit function. Both cannot be used at the same time. To enable the Remote Inhibit input control line, the RS232 interface must be disabled. This can be done using the browser interface over LAN or USB or from the front panel. If the Remote Inhibit function is needed, use the USB interface instead of RS232.

To disable RS232 from Web browser, select **SYSTEM** Menu -> **INTERFACE SETUP** and move the SERIAL CONFIGURATION ENABLE position to OFF.



To disable RS232 from the front panel, press the CONFIGURATION key to the left of the LCD, select Interfaces, then select RS232 Interface and set the Status field to **Disabled**. Refer to section 6.8.5.4 on page 182.

Note: For units with firmware revision 2.0.13 or higher, the RS232 interface is automatically disabled when enabling Remote Inhibit.

Note: If the Remote Inhibit function is enabled, the RS232 interface is still available but no hardware handshaking is available. (Xon/Xoff RS232 control only). Alternatively, the USB interface can be used instead.

Note: Units are shipped default with the Remote Inhibit state Disabled. Thus, no shorting jumper is needed to operate the power source. Changes to the remote inhibit configuration are retained after power down (Non-volatile).

Note: Master AFX units installed in cabinet systems shipped with the –OCS (Output Control Switch) option are configured with the RI function permanently set to **Remote inhibit** mode (mode 2). This prevents an operator from accidentally disabling this switch. The master AFX model number will show an “O” (letter O) postfix to indicate this configuration.

5.18.8 External MODE Relay Control

The RS232 connector also contains a relay control output pin that may be used in combination with suitable additional hardware to control a single phase mode shorting relay between phases A, B and C in cabinet systems.

“A” version models have the remote inhibit function on the Aux I/O DB25 connector instead.

This mode must be enabled in the SYSTEM screen. This control line (pin 8 and 5 on DB9 connector) puts out +5Vdc when the AFX is in FORM1 (single phase) and -5Vdc when the AFX is in FORM2 (split) or FORM3 (three phase) mode.

5.18.9 LAN Interface

The LAN interface connector is installed on the rear panel. The MAC address of the unit can be found near the LAN connector. When present, an “L” is appended to the model’s number, e.g. 3150AFX-2L.



CAUTION



Do NOT connect the RJ45 LAN (Ethernet) connector of the power source to a PoE (Power over Ethernet) port as the DC voltage will damage the LAN interface.

No special device drivers are required to use the LAN interface as it uses TCP/IP protocol but the IP address needs to be configured to operate on the user’s local area network or private network.



MAC Address

Figure 5-26: AFX Series® Rear Panel Layout

5.18.10 System Interface Bus Connectors



CAUTION

SHOCK HAZARD: DO NOT remove safety covers from the two System Interface DVI Connectors.



AVERTISSEMENT

RISQUE DE CHOC: NE PAS retirer les capots de sécurité des deux connecteurs d’interface DVI

The system interface bus is not user-accessible. It consists of two Digital Visual Interface (DVI-I dual link) connectors that are covered by a protective cover. There are no user

accessible signals on the system interface bus. It is used for system configuration cabinet systems only.

5.19 Multi-Unit Parallel Operation

Two or more AFX units can be configured as a parallel system to create a high power system. This requires at least one Master AFX unit and one or more Auxiliary units or Master units that will be used as Auxiliaries to the first Master.

Note: Auxiliary units or Master units used in an auxiliary position must be of the same power output as the Master unit so each unit delivers the same amount of current /power into the load.

5.19.1 Load Connections on Parallel Systems

Paralleling two or more units requires that their outputs are tied together using equal length load cables from each unit to the load. A common coupling terminal block may be used to combine outputs in combination with larger size load wires to the load. Make sure the appropriate size wiring is used for the higher current levels obtained by paralleling two or more units.

5.19.2 Parallel System Bus Connection

For both units to operate correctly, the system bus connections between the master and auxiliary units **MUST** be made. This is done by daisy chaining the master to the first auxiliary and that auxiliary to the next one.

The system interface connectors are located on the left hand side of the rear panel and marked as follows:

PARALLEL IN On the MASTER unit, this connector is **NOT CONNECTED**. This causes the unit to become a master for other parallel units at power on. On an AUX unit, this connector is connected to a MASTER unit or an AUX unit that precedes this unit in the parallel chain.

PARALLEL OUT On the MASTER unit, this connector is connected to the first AUX unit. On the last AUX unit in the parallel chain, this connector is **NOT CONNECTED** signifying the end of the parallel chain.

The system bus uses a DVI-I Dual Link Male to Male interconnect cable with noise suppression ferrite beads. Cable length for paralleling units that are stacked in a 19" cabinet with no more than 1U space between units is 1 foot (0.3 m). Use of longer cables than 1 foot /30 cm is not recommended. If units cannot be installed in a cabinet, a longer DVI cable up to 3 feet in length may be used as an exception.

An example of the interconnect between one MASTER and one AUX is shown in the figure below.

Note: Any unused Parallel bus connector must be covered by the included safety covers.

Note AC input, AC Load and sense wiring are **NOT** included with the power source and must be supplied by the end-user.

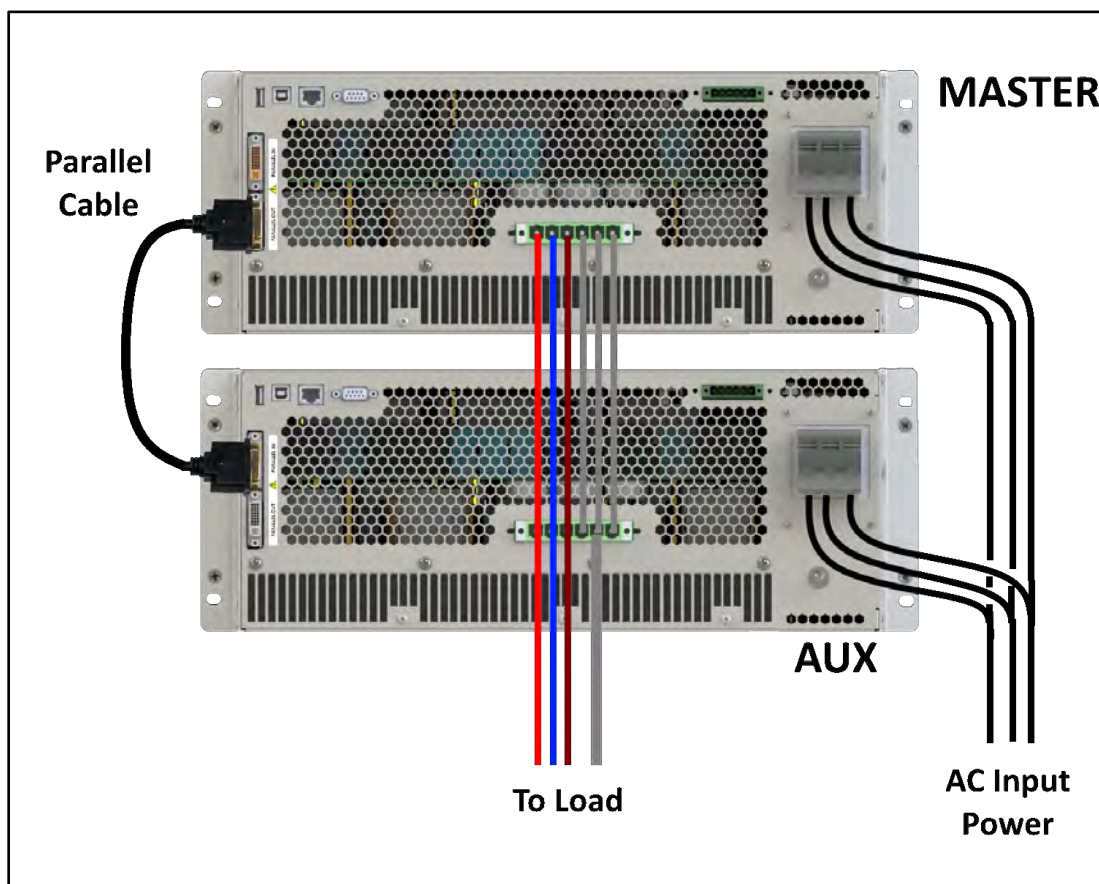

Figure 5-27: Parallel Mode Bus Connections using parallel bus cable

5.19.3 Master / Master Paralleling

Two or more masters can be paralleled as well. This allows AFX units to be used separately or as part of a larger power source system. This operation is the same paralleling using auxiliary units but only the first Master on the system bus will have an active front panel. All other Masters will display the fact that they are operating in Auxiliary mode with an inactive front panel. No re-configuration of the Master unit used in an auxiliary position is needed.

5.20 Multi-Cabinet Parallel Operation Guidelines

Please adhere to the following guidelines when paralleling two or more AFX Cabinet Systems. Unless these guidelines are following, optimal current sharing between cabinets cannot be guaranteed.

5.20.1 Output Wiring

1. All output wires (Neutral, Phase A, Phase B and Phase C) from each cabinet must be paralleled. Each individual output wire from each Cabinet to the output load connection **MUST BE THE SAME LENGTH AND WIRE SIZE**.
2. **DO NOT** connect any power wiring between the cabinets. The output wiring from each cabinet must be brought to a common load termination point.
3. Keep all power connections between the AFX cabinet and the load termination point as short as possible.

Note AC input, AC Load, sense wiring and output junction terminal blocks are **NOT** included with the power source cabinet and must be supplied by the end-user. Only internal cabinet wiring and terminal blocks are included.

See diagram below for three phase output configuration parallel cabinets.

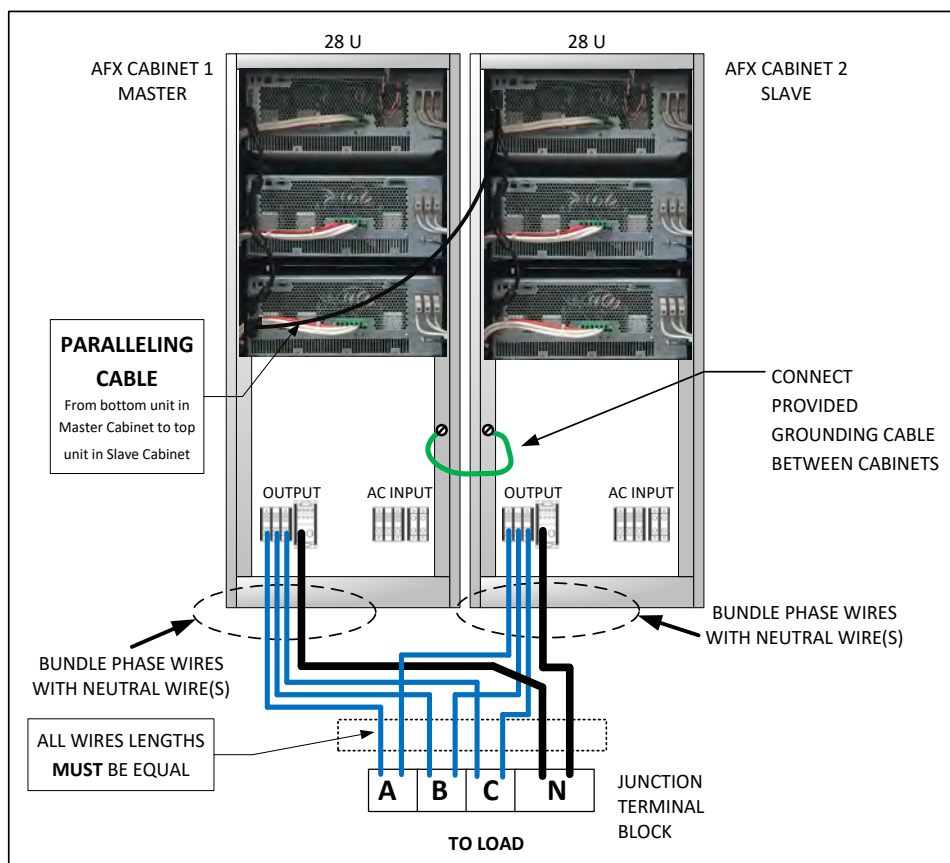

Figure 5-28: Multi-Cabinet Parallel Configuration Output Wiring - 3 Phase

5.20.2 System Grounding

1. All AFX Cabinet systems **MUST** be properly grounded to the local facility ground using the provided **GROUND** terminal on the AC input terminal block located inside the cabinet.
2. In addition to individual facility ground connections, Multi-Cabinet units must be grounded to each other. This may be accomplished by connecting a ground cable to the rear of the cabinet rack on the designated Master Cabinet, passing the cable through the Input / Output power strain reliefs, and terminating the cable on the rear of the cabinet rack of the designated Auxiliary cabinet.

Refer to diagram above for suggested ground wire routing between two cabinets.

NOTE: Each cabinet should still be ground to facility ground.

5.21 Transformer Options

Standard AFX Series AC and DC power sources support output voltages up to 332V Line to Neutral. For higher output voltage applications, an optional set of step up transformers can be ordered to boost the output voltage. The available AFX Transformer option provides 400V L-L. Higher voltage options are available on request.

This section describes the installation and use of the 400V transformer option for either single AFX units up to 15kVA or for higher power AFX Series cabinet systems.



Figure 5-29: Rack Mount Chassis for 6kVA to 15kVA Transformer Option

5.21.1 T Option 4U Chassis

The rack mount transformer options can be used on a bench or installed in a standard 19" instrument rack. This model supports the following AFX models:

- 360AFX-2AG, 360AFX-4AG
- 390AFX-2AG, 390AFX-4AG
- 3120AFX-2AG, 3120AFX-4AG
- 3150AFX-2AG, 3150AFX-4AG

Technical specifications can be found in Section 4.

5.21.2 Rack Mount T Option Installation

Whether used on a bench or installed in a cabinet, it is strongly recommended that the T option chassis be placed directly below the AFX unit it is used with as shown below. This allows for the shortest possible connections between the AFX and the transformer chassis.



Once interconnected, there is no need to change load connections or output wiring as the transformer option is automatically bypassed – removed from the output - when not in use. This allows it to remain in place at all times.

5.21.3 Unpacking T Option Chassis



CAUTION

THIS UNIT IS HEAVY. Two persons are required to lift or carry this unit. **DO NOT** attempt to lift alone. **DO NOT** use the front panel rack handles alone to lift this unit. The unit must be supported in front and back when carrying.



AVERTISSEMENT

CET EQUIPEMENT EST LOURD. Deux personnes sont requises pour transporter ou soulever cet équipement. **NE PAS** tenter de soulever ou déplacer seul. **NE PAS** utiliser les poignées en face avant pour soulever l'appareil. L'équipement doit être pris en charge à l'avant et à l'arrière pour le transport.

The AFX Transformer chassis weighs nearly **200 lbs** so it is highly recommended that lifting aids be used to remove the unit from its packaging. To assist in removing the unit from its package, two flip-down grab handles are located on each side of the chassis towards the rear.

Note: These grab handles should be removed when installing the transformer option in a 19" cabinet. When using the chassis on a bench, they can be left in place.



5.21.4 Cabinet Installation

When installing this option in a 19" rack, either heavy-duty rack slides or heavy-duty L- brackets **MUST** be used to support the weight of the unit. Contact customer services for available slides and L-brackets.

Refer to the cabinet shown to the right for details.

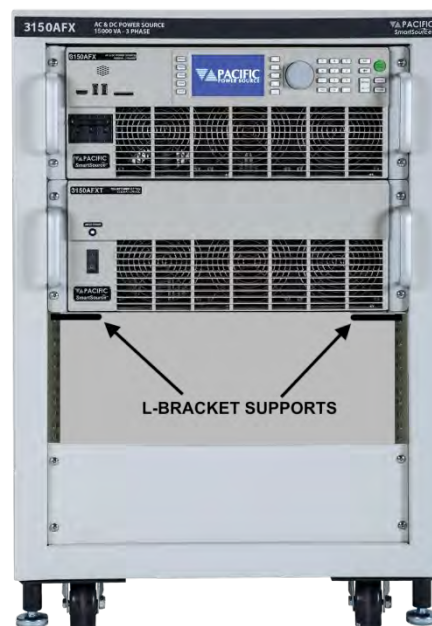

5.21.5 T Option Chassis Rear Panel Connectors

There are several connectors located on the rear panel of the Transformer chassis that are used to route power and voltage sense as well as Auxiliary I/O signals used to control the transformer option. Refer to figure below.

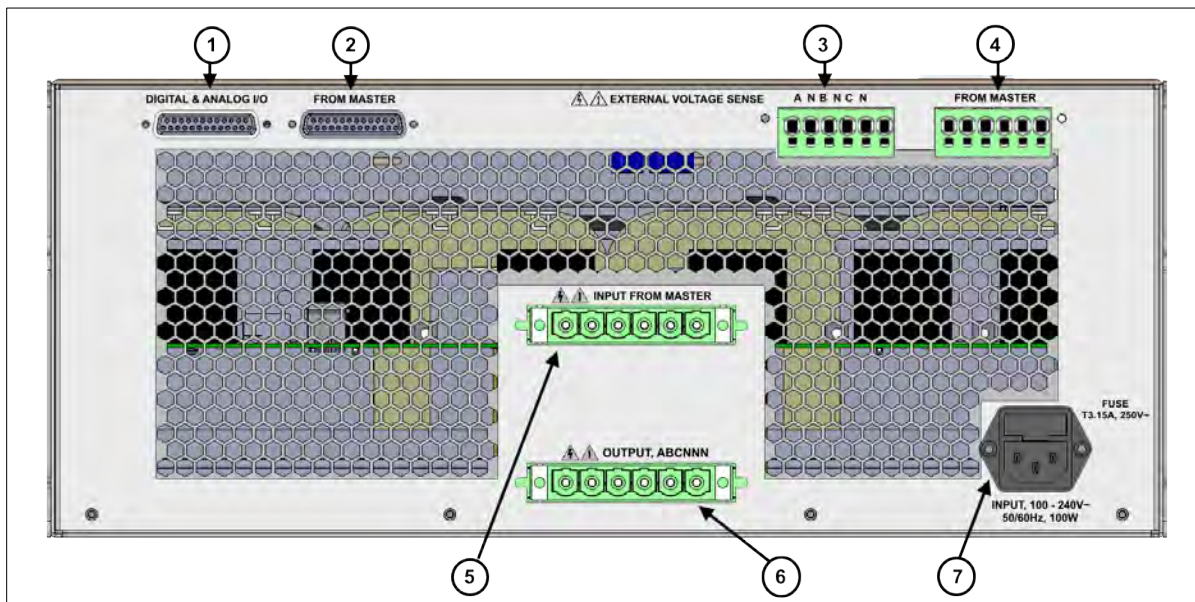

Legend for rear panel connectors is shown in the table below.

Call Out	LABEL	Description
1	DIGITAL & ANALOG I/O	Auxiliary I/O connector pass-through from Master AFXT. This connector may be used to access any Auxiliary I/O connections that are not reserved for Transformer option control.
2	FROM MASTER	Auxiliary I/O connection from master AFXT power source Auxiliary I/O connector. Use the provided DB25 Male-Female cable to connect the Master Aux I/O connector to the Transformer chassis.
3	EXTERNAL VOLTAGE SENSE - ANBNCN	External Voltage Sense Connector. Connect to load for external voltage sense. Note that the External Voltage sense connector on the master AFX unit is not accessible when the transformer option is installed.
4	EXTERNAL VOLTAGE SENSE - FROM MASTER	External Voltage Sense connection from master AFX External Voltage Sense connector. Use the sense wire harness to connect the Master AFXT External Voltage Sense to the Transformer chassis using this connector.
5	INPUT FROM MASTER	Power input from Master AFX to Transformer Chassis. Connect the provided Power Wire Harness from the Master AFX output connector to the Transformer chassis using this connector.

Call Out	LABEL	Description
6	OUTPUT, ABCNNN	Power Output Connector for Transformer chassis. Connect the load using this output connector using the Phase and Neutral positions shown. Note that all three neutral connections are shorted together internally.
7	INPUT	AC input connection. Use a standard IEC modular line cord to connect to local 115V or 230V utility voltage. Without this power connection, the transformer chassis is inoperative and in bypass mode. The AC on/off switch is located on the front panel of the of transformer chassis.

Table 5-8: Transformer Option Chassis, Rear Panel Connectors

5.21.6 AFX Power Source to T Option Connections

The required connections between the AFX power source and the transformer option chassis are shown in Figure 5-30 below.

Note AC input, AC Load and sense wiring are **NOT** included with the power source and must be supplied by the end-user.

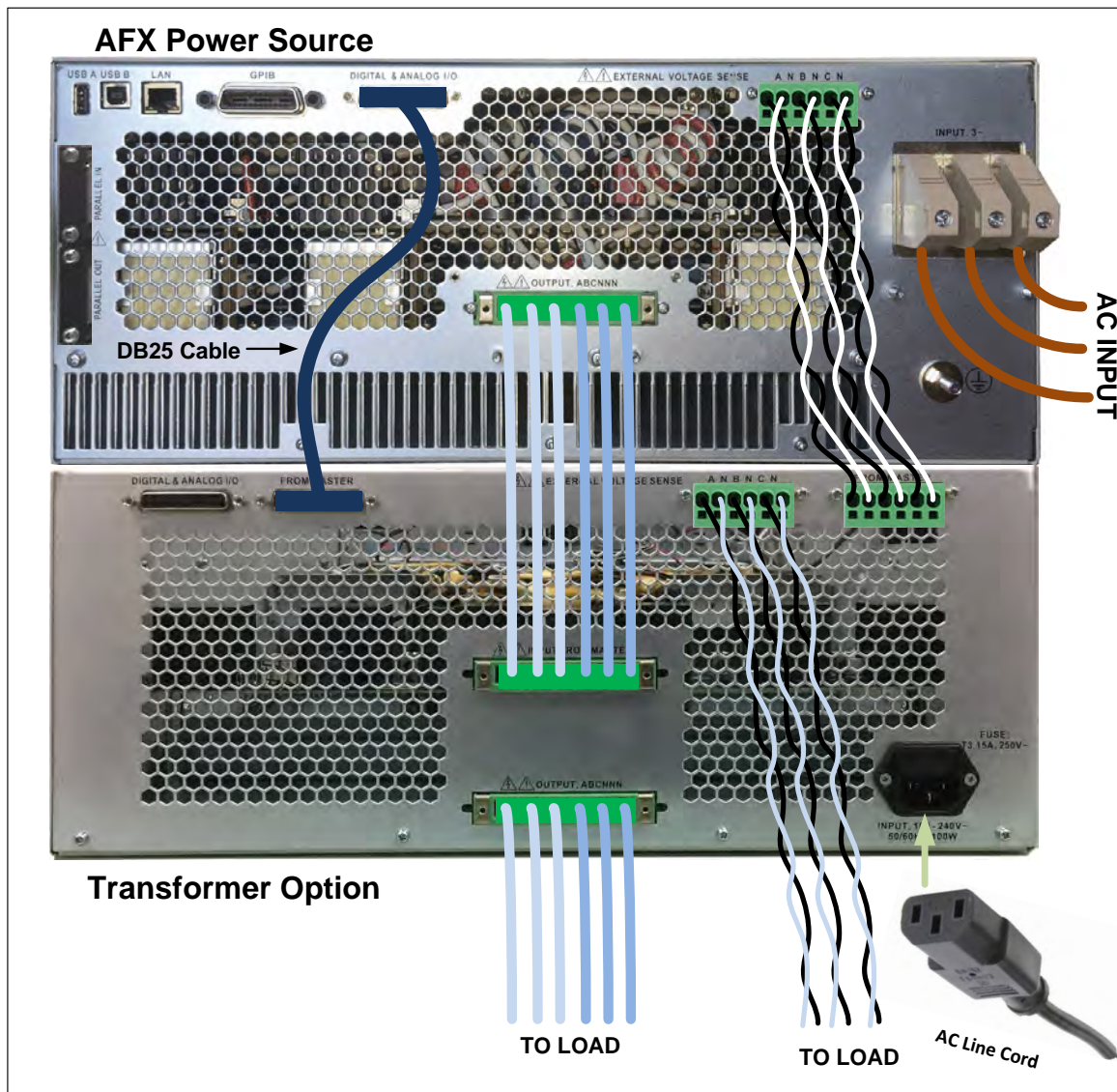

Figure 5-30: Interconnections between AFX Power Source and Transformer Option Chassis

For operating information, refer to Section 6.4.

6 Front Panel Operation

This Chapter provides an overview of front panel operation for the AFX Series® AC power sources. For remote control operation, refer to Section 8 “Remote Control Programming” of this manual for an overview of available programming commands.

6.1 Front Panel Layout

The front panel layout is shown in Figure 6-1 below. The number of buttons is kept to a minimum to ensure simple front panel operation for casual and experienced users alike. The shuttle knob is used to slew parameter values and move through menus to make selections.

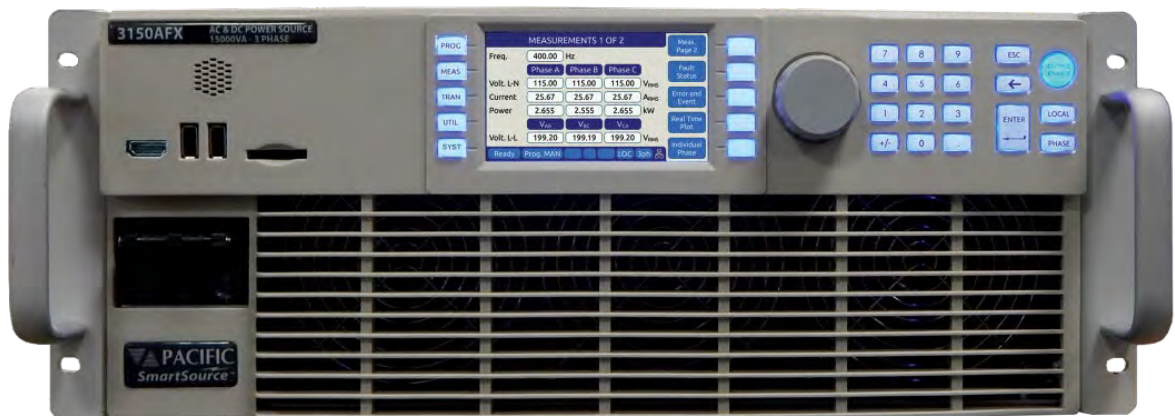
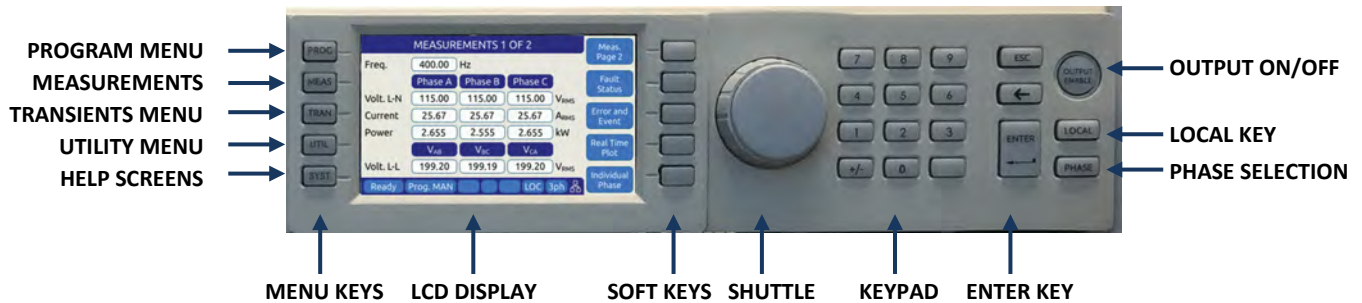

Figure 6-1: AFX Series® Front Panel View

A large backlit LCD display is located in the center. Most user controls are located directly to the right of the display. The power ON/OFF circuit breaker is located in the lower left corner of the front panel.

6.1.1 Keyboard Buttons

There are several groupings of push buttons that make up the front panel. They are grouped as follows:



Group	Function
Menu Selection Keys	These keys select the available top-level menus. Sub menus may be accessible using any of the available soft keys within each top-level menu.
Soft Keys	Soft keys change function as indicated by the decal directly to the left of the soft key on the LCD display.
Shuttle	See next section for details on shuttle operation.
Decimal Key Pad	The decimal key pad is used to enter parameter values directly. Values may also be set using any available soft key or the shuttle.
ENTER Key	The ENTER key confirms a selection or setting made with the decimal key pad. Until confirmed by pressing the ENTER key, selections and values will be shown grayed out on the LCD display to indicate they have been edited/changed but have not yet taken effect. This allows multiple parameters in the same screen to be edited with all new setting values taking effect at once when the ENTER or UPDATE ALL soft key is pressed.
ESC Key	The escape key backs out of a menu or selection and returns to a previous level.
Back Space Key (←)	This key backs up one position erasing the last digit value entered.
OUTPUT ENABLE	The OUTPUT ENABLE key is used to toggle the output on or off. If the output is ON, this key will be lit.
LOCAL	Returns the instrument to local control mode allowing front panel operation. This key may be disabled over one of the remote control interfaces. While in REMOTE, the keyboard is locked out. The LOCAL key can also be used to capture an LCD Image and store it as a .png image file in internal memory. To do so press and hold the LOCAL key, then press the 1 key. Screen images are saved in folder "internal/screenshots".
PHASE	The PHASE key is used to select a specific phase on three phase models. On single phase models, the selected phase is always A and this key has no function.

6.1.2 Shuttle Knob

The shuttle knob or rotary digital encoder is used to navigate (scroll) through menus and select fields to modify settings. The shuttle knob also includes a SELECT push button function. Pushing in the shuttle knob (SELECT) while on a data field will allow the value to be slewed up or down.

NOTE: Unlike when using the decimal keypad to enter a value, the SELECT shuttle mode will cause the output to change immediately. This allows slewing of the actual output value.

Once the final value is reached, pressing the shuttle again will take it out of slew mode and back into scroll mode.

6.1.3 PC Monitor Output

A PC monitor output connector is located on the front panel's left side. This connector is marked with a monitor icon as shown here. This allows connection of a computer monitor. When connected, the monitor will display the information otherwise shown on the front panel LCD screen and the LCD screen itself will be off.



This feature allows for the connection of a touch enabled LCD monitor to the Video Output the front panel as well. When detected by the AFX, a message will pop-up asking the operator to change to the external screen. If accepted, the front panel LCD will turn off and the AFX screen will be display on the monitor along with a touch panel to operate the unit. The actual front panel keypad will remain active as well. This feature is useful for operator training or in control rooms where being able to read the measurement screen from across the room is required. A USB connection to one of the AFX USB ports is required to use the monitor's touch feature.

To return the display to the LCD screen, unplug the monitor.

6.1.4 USB Host Ports

Two USB host ports are located on the left hand side of the front panel. These ports will accept a USB memory device or a USB peripheral such as a mouse or keyboard. These USB ports are marked with the standard USB symbol as shown here.



6.1.5 SD Card Memory Slot

A SD Card memory device slot is located on the left hand side of the front panel. This slot will accept a standard SD memory card. The SD Card slot is marked with the symbol shown to the right here.



6.2 OUTPUT ENABLE Button

The circular Output Enable (On/Off) button is located on the right hand side of the front panel keypad. Its unique circular shape makes it easy to find so the output can be turned off quickly if needed.

6.2.1 OUTPUT State Indication

The state of the output is indicated by the back light color of the Output On/Off button. A blue color indicates the output is OFF, a green color indicates the output is ON.

6.2.2 Energy Savings Modes

The AFX Series® was designed to conserve energy when powered on but not in actual use to power a load. This situation is common as adjustments are being made to the setup or the load before any power is applied. This mode is controlled by the state of the Output. If the output is off, the AFX will enter one of two energy savings modes:

1. **SLEEP MODE** In sleep mode, all three inverter stages are switched off. If the internal heatsink is sufficiently cool, all fans are turned off as well. This essentially means the power source draws almost no power at all yet the front panel controls, displays and all digital control interfaces remain operational so any required program changes can be made.
2. **STANDBY MODE** In standby mode, only the output inverter stage for each phase is turned off. This means the first two stages remain on while the output is off. This means the fan will run at its lowest speed setting for quieter operation. This mode is considered a fast startup mode.

The desired energy savings mode can be selected from the front panel or via one of the remote control interfaces using the OUP:FAST command (See section 8.7.1.).

6.2.3 Output On Response Times

Turning the output ON means that any power stage that was disabled for energy conservation purposes will be started and allowed to settle. This includes the output inverters. Once all power stages are up and running, the output relays are closed and whatever programmed output mode, voltage and frequency (if not in DC mode) will be applied to the load. If all stages were off – power source in sleep mode – this process can take up to 2.2 seconds. If the output control mode is set to FAST mode however, only the inverters are ever turned off and output can be applied within 200 msec, which is typical for older design power source with no energy saving features or sleep mode capability.

6.3 Menu Keys

The various menus and settings available to the user from the front panel are detailed in this section of the manual.

All available menus can be accessed using the Menu keys to the left of the LCD display. The following five keys are available.

MENU KEY	MENU SCREEN	Description
PROG	PROGRAM	Programming of output parameters
MEAS	MEASUREMENTS	Measurements
TRAN	TRANSIENTS	Transient programming and execution
CONF	CONFIGURATION	Configuration Screens
SYST	SYSTEM	System Settings, Interface Configuration and Calibration

Table 6-1: Available Menu Keys

Following sections cover each aspect of the front panel screen and parameters in more detail.

6.4 PROG – PROGRAM Screens

All output parameters can set from the PROGRAM screen. This screen has a list of available parameters on the main PROGRAM screen. Each parameter can be changed by highlighting the field and either slewing the value using the shuttle knob or entering a value using the numeric key pad. The difference between these two data entry modes is that slewing causes the output to change as the knob is turned while using the keypad allows one or more parameters to be preset to a new value which won't become active until the "Apply All" soft key or the ENTER key is pressed.

Thus, to slew a value, proceed as follows:

1. Use shuttle to move the active field to the parameter you want to slew.
2. Press the shuttle once to enter the slew mode. The selected field will be highlighted.
3. Use the shuttle to increment (*clockwise*) or decrement (*counterclockwise*) the selected parameter. Note that these changes take effect immediately resulting in the active output slewing up or down.

Note: This assumes the output is ON. If the output is OFF, the new value will be in effect and apply at the output as soon as the output is turned ON.

To slew a parameter while observing the MEASUREMENT screen, proceed as follows:

1. Use shuttle to move the selected field to the parameter you want to change.
2. While on the desired parameter (e.g. Voltage or Frequency), DOUBLE-PRESS the shuttle (similar to double clicking a mouse button).
3. The MEASUREMENT screen will appear with the parameter to be slewed visible in the header bar.
4. Use the Shuttle to slew the parameter up or down. The value will be displayed in the header bar of the measurement menu.
5. When done, press the PROGRAM key to return to the regular PROGRAM screen and exit this interactive mode.

With the parameter field selected, enter a new value using the numeric keypad.

To change one or more values but not change the actual output till all parameters are preset, proceed as follows:

6. Use shuttle to move the selected field to the parameter you want to change.
7. With the parameter field selected, enter a new value using the numeric keypad. Note that all fields are now shown with a gray background (Edit mode active)
8. Once satisfied with the new value, move to the next parameter you want to change.
9. Once all values are set to the new desired set value, press the ENTER key or the "Apply All" soft key.

6.4.1 Power On Settings

The AFX Series will normally power up with the last settings in effect at turn-off for units with firmware revision 1.6.0 or higher. Older firmware units will come up with factory default settings.

Starting from firmware revision 1.6.0, this behavior is determined by the the “SOURce:INITial” command. This feature is active by default. This makes the AFX “remember” all the settings after cycling power.

This mode can be disabled by using the remote control command:

SOURce:INITial 0

This setting is retained in non-volatile (FLASH) memory.

6.4.2 PROGRAM Output Parameters

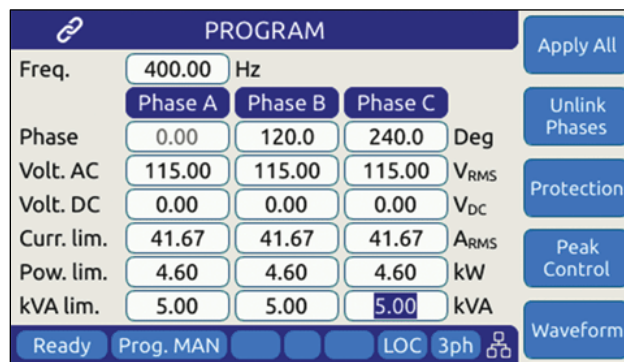

Figure 6-2: PROGRAM Screen

The two data entry methods described apply to the parameters on the main PROGRAM screen. This includes those shown in the table below.

PARAMETER	Range	Unit	Description
Frequency	15 - 1200	Hz	Output frequency
Phase	0.0 – 359.0	Degrees	Phase angles for phase B and C
Voltage AC	0 – 300	V rms	AC output
Voltage DC	0 - 425	Vdc	DC output
Current limit	0 to Max	A rms	RMS Current Limit
Power limit	0 to Max	W	True Power Limit
kVA limit	0 to Max	VA	Apparent Power Limit

Table 6-2: Available Output Parameters on PROGRAM screen

Each screen has up to five soft keys on the right hand side of the display. These may change as the selected parameter changes. To move between parameter fields in any screen, use

the shuttle knob. To change a parameter, press the shuttle knob and then adjust the value by turning the shuttle. When done, press the shuttle to exit edit mode.

6.4.3 Phase Rotation / Phase Sequence

Phase rotation(aka sequence) in three-phase mode is determined by the programmed phase angles for phase B and C. Phase A is always the 0° reference and this value can only be changed when an external phase sync. Input mode is used. For normal operation, the internal phase A is used as the phase reference for B and C so phase A is fixed at 0° and the field is disabled. (Light grey instead of black text).

The default phase rotation of the AFX is the same as that of legacy PPS UPC controllers. This phase rotation is positive so when driving AC motors, the motors will turn forward.

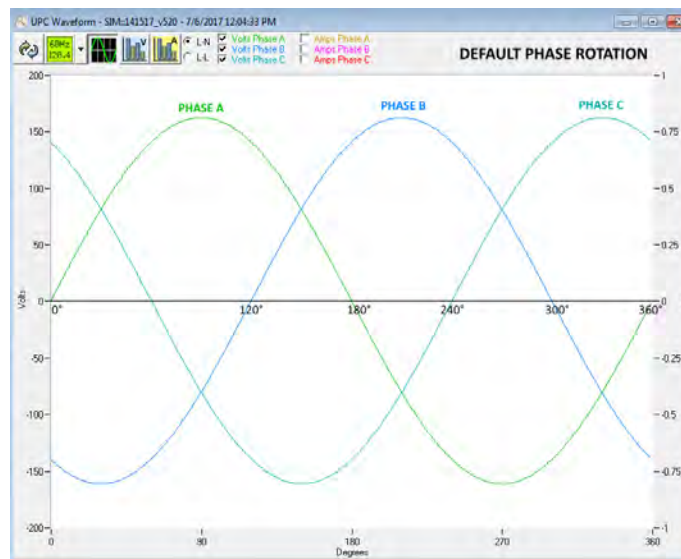

Figure 6-3: Three Phase AC mode Default Phase Rotation

Phase rotation in three-phase mode can be reversed if needed in one of three ways:

1. By swapping output connection wires B and C to the load.
2. By reprogramming the default phase setting for B to 240° and for C to 120°.
3. By selecting “Positive (Phase B leading A)” under “**Phase Rotation**” in the source configuration screen.

The reversed phase rotation is shown in the figure below for reference.

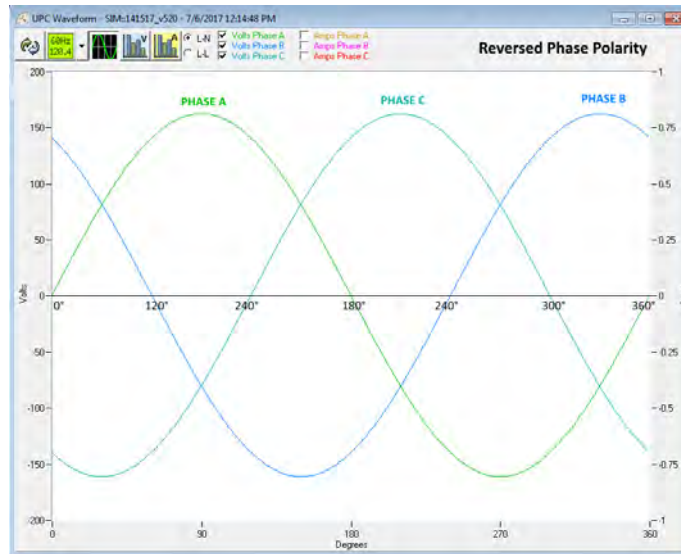

Figure 6-4: Three Phase AC mode Reversed Phase Rotation

6.4.4 Direct Data Entry - Presets

Values for Frequency, Voltage, Current, Phase and Power can be entered directly using the numeric keypad. Position the flashing cursor on the field for which you want to enter a new setting value. Once a field is selected, press the first key of the value you want.

As soon as you enter the first digit, the soft keys will display commonly used values for the parameter you are changing. For example, if you are on the Frequency fields, presets for 50 Hz, 60 Hz, 400 Hz and 800 Hz will appear.

If you are on the Voltage AC field, presets for 115 V, 230 V and 300 V will appear. A Low Voltage Range selection will be offered as well allowing you to lock in the virtual low range, which limits AC voltage entry to no more than 150 Vac. This is illustrated on the image below.

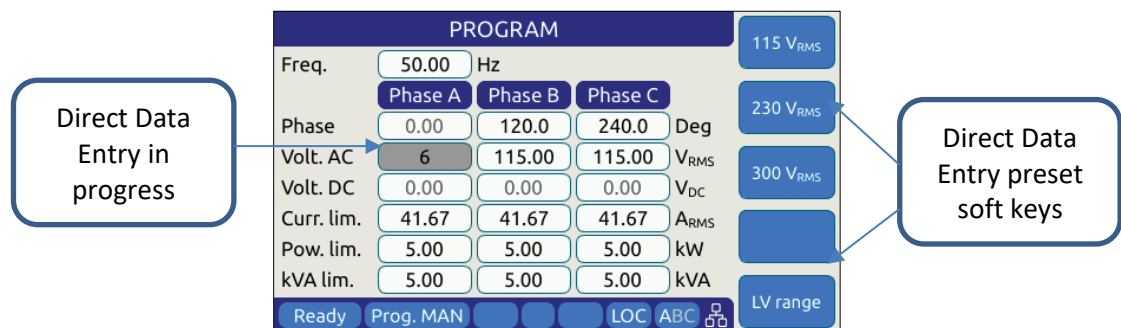

6.4.5 Customizing Output Programming Preset Soft Key Values

The power source allows the user to set up his own preferred or often used output programming values in place of the factory default selections. This can be done from the SYST menu by selecting the UNIT CONFIGURATION 2 OF 2 screen and pressing the “User Presets” soft key.

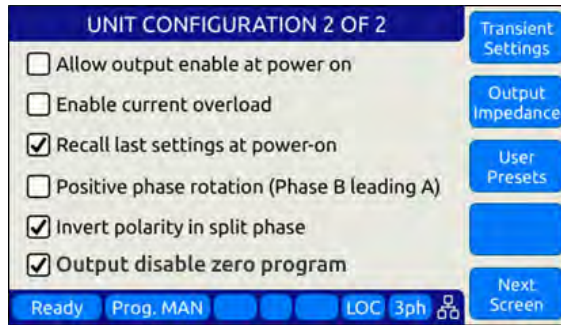

For details on change any available pre-set soft key value, refer to Section 6.7.8, “USER PRESETS Screen” on page 169.

6.4.6 Changing Shuttle Programming Resolution

Once entering EDIT mode on any programmable field – by double clicking the shuttle knob – the parameter value can be slewed by turning the knob. The setting resolution can be changed as needed. If a large value change is needed, a lower resolution will result in a faster change, e.g. changing voltage 10V per click or 1V per click. For a very small change, a 0.1V or 0.01V change per click may be more appropriate.

The selected resolution is reflected by the blinking character when in edit slew mode. To change the position and thus resolution, use the keypad numeric keys. The lowest number keys will select the smallest increment/decrement setting. The higher number keys will select a larger increment/decrement setting.

The table bellows maps the keypad keys to the resolution setting.

Key Pad Key #	Position	Resolution
1 or 2		0.01
3		0.1
4		1
5		10
6, 7, 8 or 9		100
7, 8, 9		1000

Table 6-3: Changing Programming Resolution

6.4.7 Phase Mode Selection

Setting output parameters when the AC power source is in single-phase mode (FORM1) is straightforward as there is only one phase to program. Thus, all fields displayed in the PROGRAM screen apply to phase A.

In three-phase mode, there are two ways to program most parameters other than the Frequency:

- Coupled
- Uncoupled

Coupled mode means all phases are set and changed to the same value. Thus, Voltage AC when set or changed applies to all three output phases. This method ensures output phase voltages are always balanced and is convenient for driving normal three phase loads. Coupled mode is indicated by the “ABC” status indicator on the right hand side of the status bar as highlighted below.

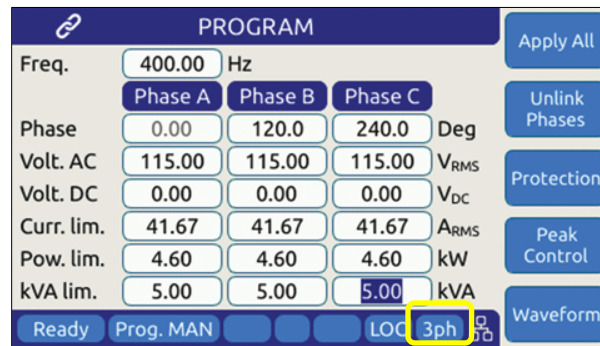

Figure 6-5: Phase Mode Data Entry Status Field

Uncoupled means each phase can be set individually. To do so, the phase to be set or changed must be selected first using the **PHASE** key located on the right hand side of the front panel keyboard. The selected phase (A, B or C) is displayed in the status bar as either “A”, “B” or “C” when in SINGLE phase mode or “3ph” will be displayed when in THREE phase mode.



6.4.8 PROGRAM Soft Keys

The following five soft keys are available on the main PROGRAM screen.

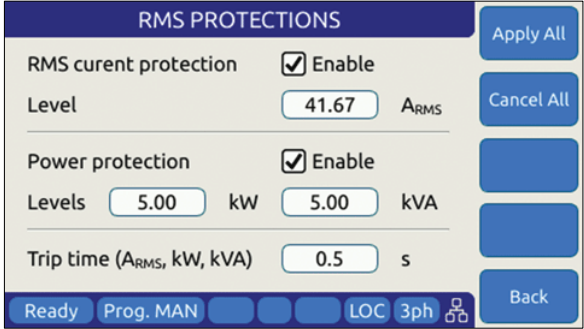
SOFT KEY	Description
Presets (SK1)	<p>Changes all soft keys to up to five preset values that may be used to change the selected parameter to any of the preset values shown on the soft key labels. This provides a quick way to set commonly used values. On AFX models with firmware revision 2.0.0 or higher, it is also possible to reprogram these presets to user specific values. Refer to Section 6.4.5, “Customizing Output Programming Preset Soft Key Values” on page 120 for details.</p> <p>The following presets are offered for the parameters listed:</p> <p>Frequency 50Hz, 60Hz, 400Hz, 800Hz, 1200Hz</p> <p>Voltage AC 115V, 230V, 300V</p> <p>Voltage DC MAX, 200V, 0V, -200V, MIN</p> <p>Current limit MAX, 15A, 4A, PEAK CURRENT</p> <p>Power limit MAX, 4kW, 2kW, 1kW</p> <p>kVA limit MAX, 4kVA, 2kVA, 1kVA</p>
Protection (SK2)	<p>Displays the POWER AND CURRENT PROTECTIONS screen shown below.</p>  <p>There are two check box options and one data field on this screen that can be set as needed:</p> <p>Enable RMS current protection Activates the programmable current limit function at the value set in the main program screen</p> <p>Enable power protection Activates power protection at W and kVA set points.</p> <p>Trip time: Determines how long the power source will allow the power level setting to be exceeded before tripping off.</p>

SOFT KEY	Description
<p>Peak Current (SK3)</p>	<p>Displays the Peak Current protection screen. This protection function is separate from the RMS current limit function. By setting the peak current protection mode, the maximum peak current is limited by the power source to the programmed level. This is done on a cycle by cycle basis. Note that a minimum setting applies as described in section 6.4.9, next page.</p>  <p>The level can be set using the shuttle or key pad. To enable or disable this function, scroll to the “Enable peak current protection” check box and press the shuttle to toggle on or off.</p>
<p>Waveform (SK4)</p>	<p>Displays the Waveform selection screen. This function allows the active waveform shape to be changed. Available waveform selections are:</p> <p>Sinewave, Clipped Sinewave 1% THD, Clipped Sinewave 2% THD, Clipped Sinewave 5% THD, Clipped Sinewave 10% THD, Square and Triangle.</p>  <p>Select waveform using the shuttle. Each waveform can be previewed. With the desired waveform displayed, press the “Apply” soft key to confirm. This will take you back to the PROGRAM screen.</p>
<p>Apply All (SK5)</p>	<p>The “Apply all” soft key is used to confirm all presets made to program parameters in the PROGRAM screen. When pressed, all newly set values are applied to the output and the parameter background colors revert back to white.</p>

Table 6-4: PROGRAM screen soft keys

6.4.9 Peak Current Protection Minimum Setting

The programmable peak current protection feature allows the user to limit the peak current that is applied to the EUT. In order to do this, the power source has to clamp the output voltage. The power source will do so when the set limit is exceeded on a switching cycle by switching cycle bases. There are some practical considerations to take into account as some of the current delivered by the power source can be absorbed by the internal output filters.

If the peak current limit value is set too low, it may prevent the power source from delivering the programmed output voltage at higher frequencies. Even if no load is connected to the power source, some reactive power is required to generate the output voltage. This reactive current will be limited by the peak protection level set point so a minimum value applies. The formula that determines the minimum set value for peak current protection is:

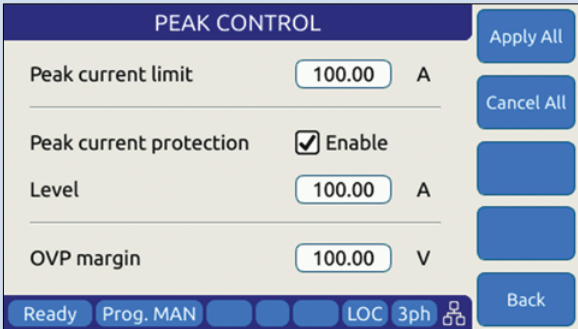
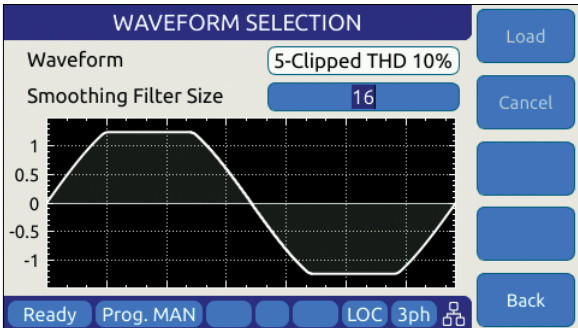
$$I_{pk} > 1 A + Vac_setpoint * 0.09 * Freq_setpoint \text{ (in kHz).}$$

This formula applies in three phase mode for AFX models of 15kVA and below. For example, with an output AC voltage setting of 230Vac and a frequency setting of 1000 Hz, the minimum set value would be:

$$I_{pk} \text{ min} = 1 + 230 * 0.09 * 1 = 21.7 A_{peak}$$

If the set value is below this level, the following two conditions will occur:

A) The voltage measured at the output will be less than desired.

Example 1:

- Frequency 400Hz.
- Voltage 120Vac.
- Peak current limit 1A.
- The voltage measured at the output will be limited to 25.6Vrms

Example 2:

- Frequency 400Hz.
- Voltage 120Vac.
- Peak current limit 2A.
- The voltage measured at the output will be 54.6Vrms

Example 3:

- Frequency 400Hz.
- Voltage 120Vac.
- Peak current limit 3A.
- The voltage measured at the output will be 83.22Vrms

The higher the frequency and the AC voltage set points are, the lower the measured voltage at the output will be unless the peak current protection level is set high enough to prevent this condition.

- B) An Error event will be triggered in the error and event queue in order to notify the user. The error message is:

"Peak current limit setting is too low for the desired voltage and frequency."

as shown in the screen capture below.

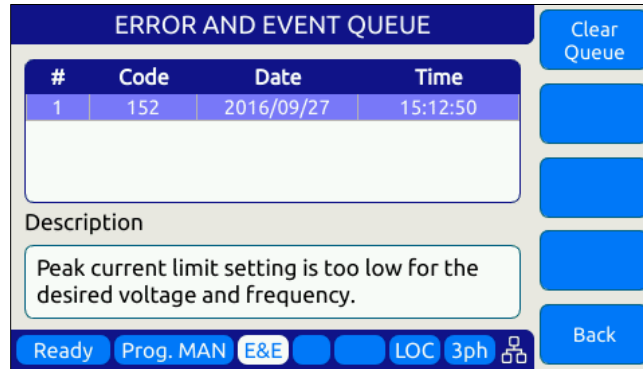



6.4.10 Available Waveforms

The AFX Series® is supplied with 10 pre-loaded waveforms but can hold a total of 200. The default content of the first 10 registers are shown in the table below. Also shown are the waveform number names and the waveform description each waveform.

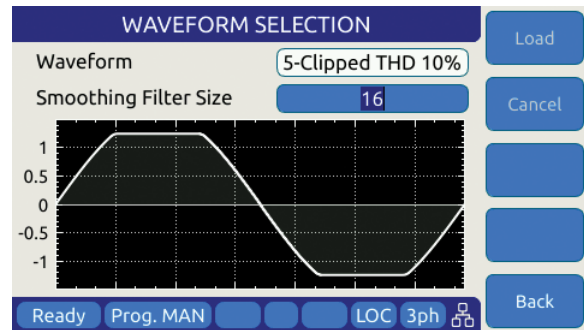
For waveforms with high harmonic content – e.g. sharp transition or fast edges – the smoothing filter feature can be used to smooth out these high frequency events to reduce over/undershoot as needed. The value entered indicates the number of waveform data points that will be averaged to obtain a smoother wave shape. Preview of the resulting smoothed waveform is shown on the LCD screen.

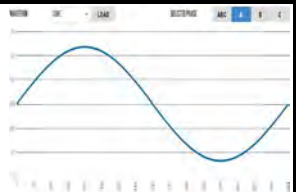
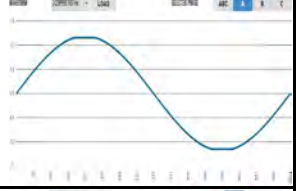
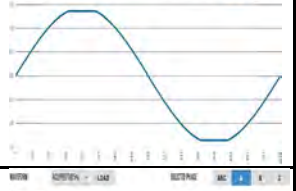
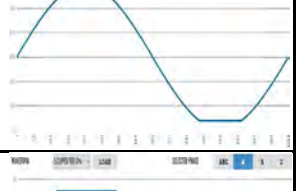

Name	Description	Image	Notes
1	SINE		Standard sine wave. No harmonic content ¹ . This is also the default selected waveform at power on unless a power-on setup is recalled. Waveform 1 is fixed and CANNOT be changed! Note 1: See SOURCE:WAVEFORM:SINEwave command
2	CLIPPED THD 1%		Clipped sine with 1% total harmonic voltage distortion due to flat topping of sinewave peaks.
3	CLIPPED THD 2%		Clipped sine with 2% total harmonic voltage distortion due to flat topping of sinewave peaks.
4	CLIPPED THD 5%		Clipped sine with 5% total harmonic voltage distortion due to flat topping of sinewave peaks.
5	CLIPPED THD 10%		Clipped sine with 10% total harmonic voltage distortion due to flat topping of sinewave peaks.



Name	Description	Image	Notes
6	SQUARE LF		Square wave. Consists of fundamental and all odd harmonics. The LF (low frequency) version is recommended for use below 100Hz.
7	SQUARE HF		Square wave. Consists of fundamental and all odd harmonics. The HF (high frequency) version is recommended for use above 100Hz.
8	SAWTOOTH LF		Saw tooth. Consist of fundamental and both odd and even harmonics. Note: Not recommended for conventional power applications. LF use < 100Hz.
9	SAWTOOTH HF		Saw tooth. Consist of fundamental and both odd and even harmonics. Note: Non-linear! Not recommended for conventional power applications. HF use > 100Hz.
10	TRIANGLE		Triangle. Similar to saw tooth but at same fundamental as a sine wave. Contains fundamental and odd harmonics with amplitudes that roll off as the inverse square of the harmonic number. (1/3, 1/9, 1/25 etc.).
11 ~ 200	User Defined		Waveforms 17 through 200 can be added as needed.

Table 6-5: Available Included AFX Series® Waveforms

6.4.11 Waveform Smoothing Filter

User defined or arbitrary waveforms can contain sudden transients, which equates to high order harmonics. Such types of waveforms can result in over or undershoot when applied at higher frequencies (i.e. 400Hz to 800Hz). An extreme example of this is a pure square wave, which would require infinite output bandwidth to accurately reproduce.

To mitigate this effect, the AFX Series® offers a smoothing filter feature (*FW rev 1.3.3. or higher required*) that may be used to smooth these transient. This filter using a moving average method over 1 to 101 samples to reduce the slew rates of these abrupt transitions. A value of 1 represents Disabled (default setting) so no smoothing takes place.

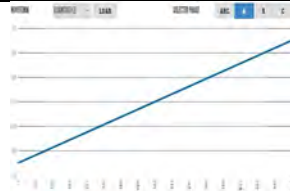
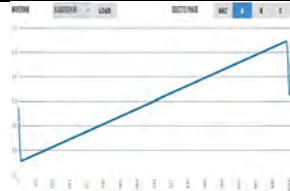
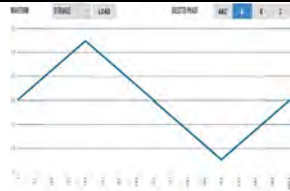
The two samples below show the same square waveform with no smoothing (disabled) and smoothing over 100 waveform data points (max.).

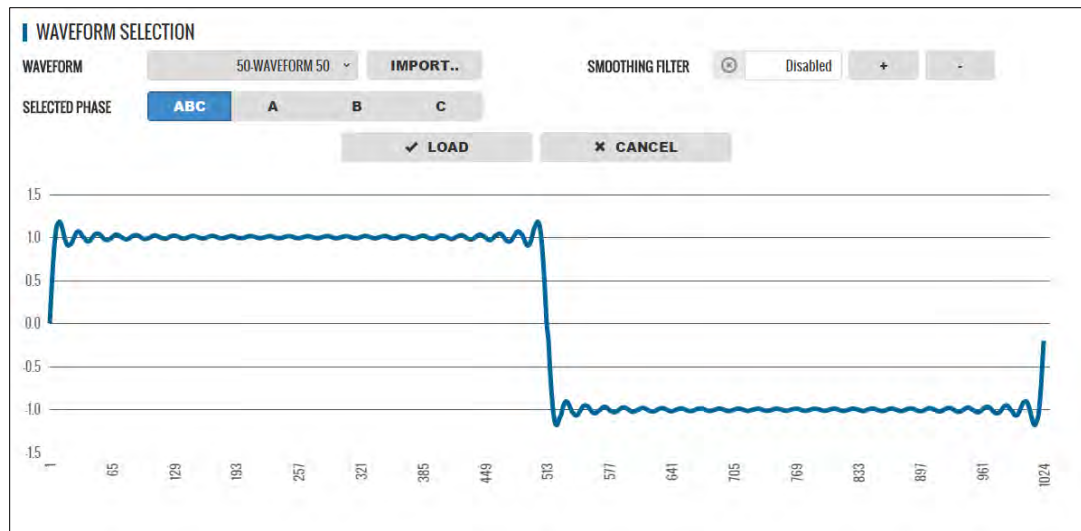

Figure 6-6: Waveform with no Smoothing Filter Applied



Figure 6-7: Same Waveform with maximum smoothing Filter Applied

6.4.12 AUTO RMS Function – Steady State

The AUTO RMS mode, if enabled, causes the AC voltage output value to be calculated as a true RMS voltage of the waveform selected. This means the output RMS voltage will remain at the programmed level regardless of a change in waveform shape. This may or may not be what the user intends. For example, adding a transient spike on a sine wave as part of a user defined waveform will cause the overall RMS value to increase so the sinewave portion of this user defined waveform will be attenuated somewhat when used.

When AUTO RMS is disabled, RMS calculation of substituted waveforms does not occur so the output RMS voltage may change from the set value if the waveform selected for output is not a sine wave. This mode is preferred if switching to a user waveform that has a different mathematical RMS value from a sine wave should NOT result in the output voltage amplitude being adjusted to maintain the same RMS level as with a sine wave. As in the previous example, adding a spike or a dip in part of the sinewave will not affect the output amplitude of the sinewave portion.

Note: The setting of the AUTO RMS mode is important when CSC mode is used as CSC mode uses the measured output RMS voltage to adjust the output to maintain voltage regulation.

This mode can be set by sending the **[SOURCE:]WAVEFORM:AUTORMS** command over one of the Digital control interfaces.

The following examples illustrate the different behaviors between AUTO RMS mode ON and OFF.

6.4.12.1 AUTO RMS ON Mode:

In the example below a, 100Vrms sine wave is swapped for a half wave rectified ac waveform. The RMS value of this non-sinusoidal waveform is 1.414x that of a sine wave so the peak value is increased to maintain a 100Vrms output voltage with this wave shape. Not that there is a considerable amount of DC offset present as well due to this non-symmetrical waveform.

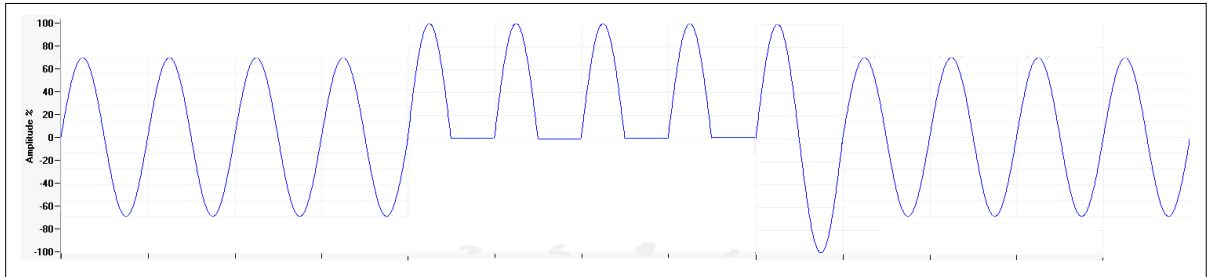

6.4.12.2 AUTO RMS OFF Mode:

Same waveform example but this time with AUTO RMS mode OFF results in no change to output peak voltage but the actual RMS voltage during these four cycles is only 70.7Vrms instead of the 100Vrms programmed setting.

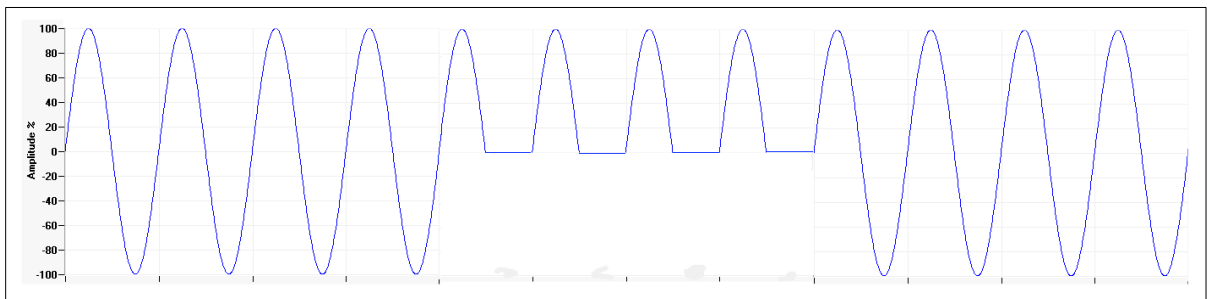

Note: In UPC Compatibility mode, this mode is always enabled.

6.4.13 Extended AC Voltage Range Operation

The standard AC voltage range maximum setting for line-to-neutral voltage programming is 300Vac rms. This setting is equivalent to 520V line-to-line in three-phase mode. However, keep in mind that some V/F combination limits will be in effect (both voltage and frequency cannot be high at the same time). For examples, the user can set a frequency user limit of 3000Hz if the programmed voltage is low enough. The same for the voltage, it can be set to 312Vrms if the frequency is low enough (800Hz or less).

For applications where a higher AC voltage is required, extended voltage operation up to 320V is supported with some restrictions. These restrictions are determined by the maximum voltage setting programmed:

6.4.13.1 300 – 305 V - Max Voltage 305V_{L-N} / 528V_{L-L}

This setting reflects a 10% over voltage for 277V_{L-N} / 480V_{L-L} nominal voltage applications.

Restrictions

- **Frequency Range:** 45.00 – 100.00 Hz.
- **Phase Mode:** Available in single, split and three phase modes.
- **Output Power:**
 - Three phase – Full power (no restriction).
 - Single and Split phase – Maximum power 3kVA/kW per phase per AFX unit.

6.4.13.2 305 – 312 V - Max Voltage 312V_{L-N} / 540V_{L-L}

This setting reflects a 30% over voltage for 240V_{L-N} / 415V_{L-L} nominal voltage applications.

Restrictions

- **Frequency Range:** 45.00 – 100.00 Hz.
- **Phase Mode:** Available in three-phase mode only.
- **Output Power:**
 - Three phase – Maximum power 3kVA/kW per phase per AFX unit.
 - Single and Split phase – Not available.

6.4.13.3 Higher Voltage Settings

For applications requiring more than 312V_{L-N}, refer to the “SOURce:VOLTage:EXTend” command in the programming section of this manual.

6.4.13.4 Extended Voltage Range Power Limit Setting

Applicable output power restrictions as stated above will result in adjustment of the programmed kW and kVA power limits in the PROGRAM screen. This occurs automatically when programming an AC voltage value higher than 300 and is based on the value set and

the standard available max. power level of the AFX model used. An Event Message is generated to notify the user of this restriction.

6.4.13.5 Accessing Extended Voltage Ranges

To enable higher voltage operation, the user must first set the MAX USER LIMIT for Vac to more than 300.00V. Values from 300.00 to 312.00 will be accepted.

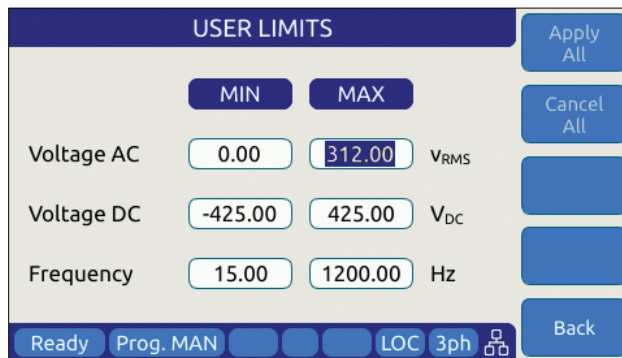
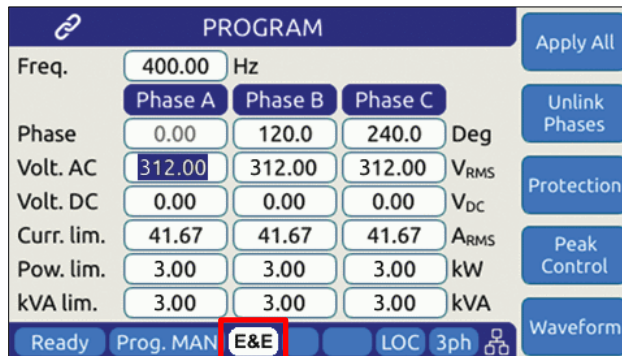

Figure 6-8: Enable Vac extended operating range to 312Vac

Once the Voltage AC MAX user limit has been set to a higher value, the PROGRAM screen will accept a Volt AC setting up to this new value as shown below.



When a value above 300 is entered in any of the available Vac setting fields, an Error & Event (E&E) message will be generated in the Error and Event Queue. The E&E field in the bottom status bar will blink to indicate a message is available. Note that the power limit fields will automatically update as needed to indicate the power limit.

For applications requiring more than 312V L-N, refer to the “SOURce:VOLTage:EXTend” command in the programming section of this manual.

6.4.13.6 Power Limit Adjustment Notification Messages

The message queue is accessible from the SYSTEM MENU.

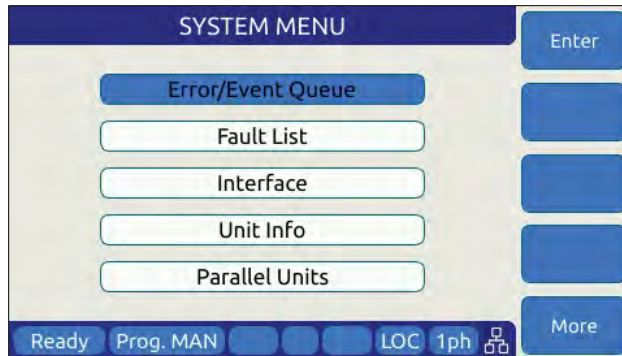

A sample of the relevant Event Message is shown below. The “Webpage interface” indicates the setting change was trigger from a browser connection. Alternative sources are “Front Panel Interface” or “Remote Interface”.

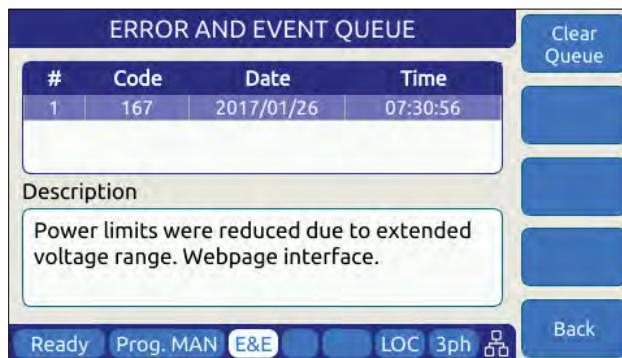

Note: Disable extended AC voltage range access, set the voltage AC MAX user limit setting back to 300.00 in the USER LIMITS screen.

6.5 MEAS – MEASUREMENTS Screens

The MEAS menu key displays the first of two measurement screens. Measurement screens are used to display measurement values taken at the output of the AC power source.

The measurements screen layouts differ between single phase and multiphase mode. If the power source is configured for single-phase mode operation, only the single phase measurement screens are available. When in three phase mode, the user can change screens between all three phases or one phase at a time using the PHASE key located below the Output ON/OFF key or by pressing the “Individual Phase” soft key (SK5).

6.5.1 Measurements Screens

The different measurement screen layouts are shown below.



Figure 6-9: Three Phase Measurement Screens

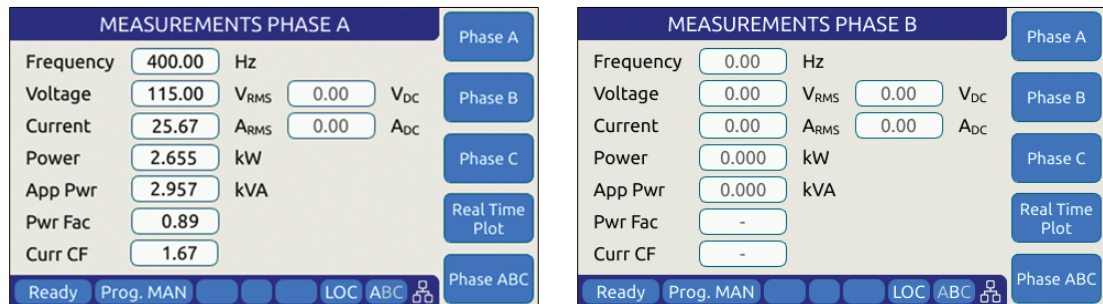
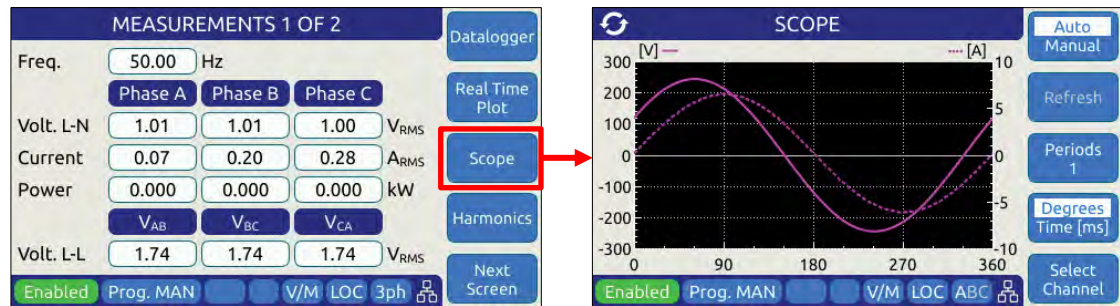

Figure 6-10: Single Phase Measurement Screens for Phase A and B

Note: The individual phase display screens contain all measurement parameters on one screen so there is one screen for each phase.

6.5.2 Scope Measurements

Scope measurements allow all voltage and current phases to be captured and displayed in the time domain. From one to four cycles of the fundamental frequency can be displayed. Display modes include all voltages, all currents, both voltage and current or individual phase selected voltage and current. Use the “Scope” soft key from the Measurement screen to select Scope measurements.



Note that voltage scope captures can be set for Line to Neutral voltage or Line to Line Voltage when in three phase mode. To select the desired mode, use the Select Channel soft key.

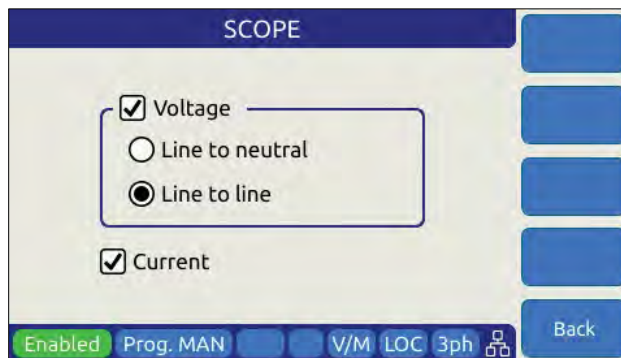

6.5.3 Harmonic Measurements

Harmonic measurements for all phase voltages and currents can be measured and displayed in either chart or table format. Use the “Harmonics” soft key from the Measurement screen to select Harmonics measurements.

The image shows four screenshots of the AFX Series power source interface. The top-left screenshot is the 'MEASUREMENTS 1 OF 2' screen, displaying various electrical parameters for three phases (A, B, C). A red box highlights the 'Harmonics' button, with an arrow pointing to the 'HARMONIC PLOT (%-N)' screen shown in the top-right. The bottom-left screenshot is another 'HARMONIC PLOT (%-N)' screen, showing a bar chart of harmonic magnitudes for orders 2 through 16. The bottom-right screenshot is the 'HARMONICS ANALYSIS' screen, which displays a table of harmonic data.

#	Mag. A [%]	Mag. B [%]	Mag. C [%]
THD	848.20	304.79	856.31
EHD	662.32	219.79	608.35
OHD	529.88	211.16	602.64
1	100.00	100.00	100.00
2	37.14	31.28	24.31
3	95.59	54.31	71.46
4	80.16	9.87	79.46
5	62.99	34.10	82.90

6.5.4 Measurement Screen Soft Keys

The following five soft keys are available on the two three-phase measurement screens.

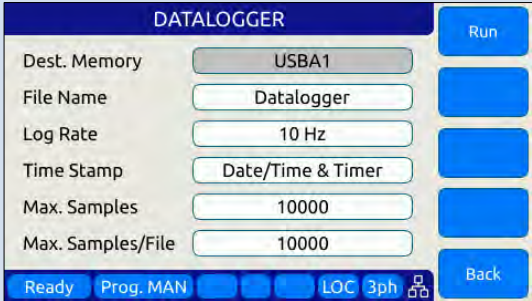
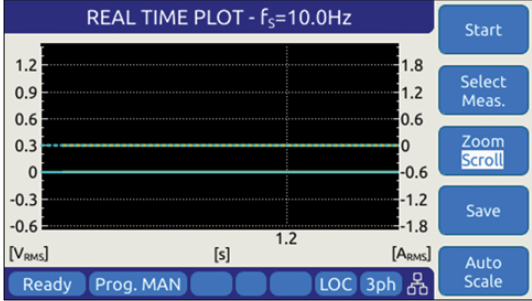
SOFT KEY	Description										
Datalogger (SK1)	<p>The Datalogger soft key allows setting the measurement data logging memory type to be selected, sample rate and no. of samples to be logged to memory. To use a usb memory stick (32GB max), insert it in one of the two USB ports on the front panel and select either USBA1 or USBA2. Only memory devices found will be selectable in addition to the default internal RAM (volatile) memory.</p> 										
Real Time Plot (SK2)	<p>Display strip chart of voltage, current or both against time. This provides a trend plot of any available measured parameter.</p>  <p>The following soft keys are available to control the time plot:</p> <table border="0"> <tr> <td>Start</td> <td>Starts time plot.</td> </tr> <tr> <td>Select Meas.</td> <td>Select parameters to display</td> </tr> <tr> <td>Zoom or Scroll</td> <td>Zoom both X and Y axis</td> </tr> <tr> <td>Save</td> <td>Saves plot data to memory device</td> </tr> <tr> <td>Auto Scale</td> <td>Auto-scale the Y axis (Amplitude)</td> </tr> </table>	Start	Starts time plot.	Select Meas.	Select parameters to display	Zoom or Scroll	Zoom both X and Y axis	Save	Saves plot data to memory device	Auto Scale	Auto-scale the Y axis (Amplitude)
Start	Starts time plot.										
Select Meas.	Select parameters to display										
Zoom or Scroll	Zoom both X and Y axis										
Save	Saves plot data to memory device										
Auto Scale	Auto-scale the Y axis (Amplitude)										

SOFT KEY	Description
<p>Scope (SK3)</p>	<p>Toggles to the Scope Measurement displac screen.</p> 
<p>Harmonicis (SK4)</p>	<p>Toggles to the Scope Measurement displac screen.</p> 
<p>Next Screen (SK5)</p>	<p>This soft key allows toggling between the two available measurement screens. The same can be accomplished by pressing the MEAS button on the left hand side of the LCD display.</p>

Table 6-6: Measurement Screen Soft Keys

6.5.5 Measurement Data Logging

Logging measurement data is easy to do using the Datalogging function. Files are saved in a comma separated value text file which is easily imported into MS Excel or other programs for analyzer and / or display purposes.

Destination memory defaults to internal RAM allowing log files to be downloaded to browsers or local drives using the web server SYSTEM -> MEMORY BROWSER menu entry.

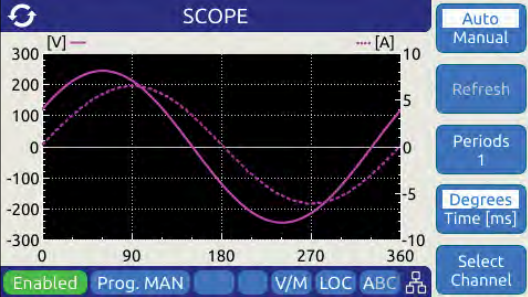
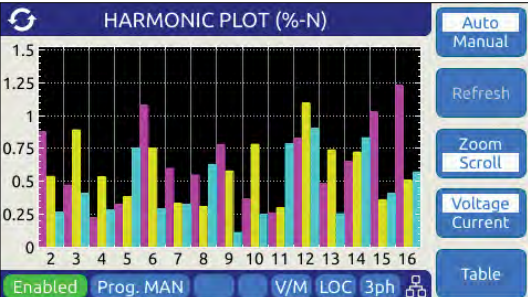
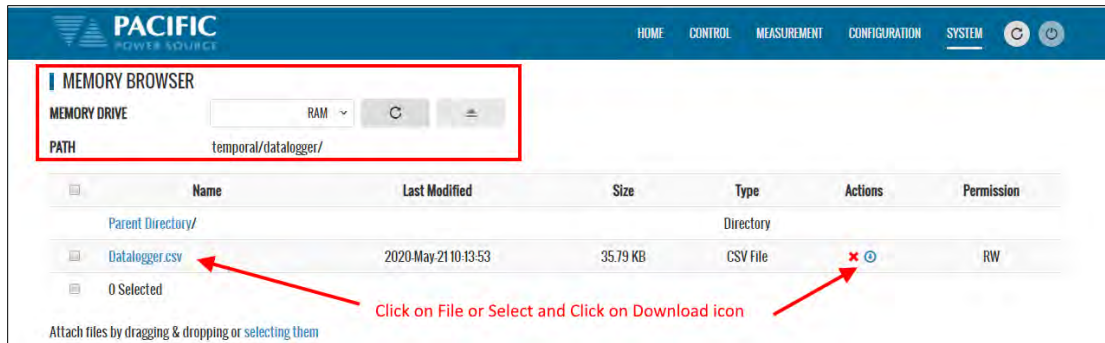

A small datalogging file sample is shown here for reference.

```
Date & Time,Timer,Frequency,Voltage VLL ACDC A-B,B-C,C-A,Voltage VLL AC A-B,B-C,C-A,Voltage VLL DC A-B,B-C,C-A,Voltage LN ACDC A,B,C,Voltage LN AC A,B,C,Voltage LN DC A,B,C,Current RMS A,B,C,Current DC A,B,C,Power A,B,C,App. Power A,B,C,Power Factor A,B,C,Peak Current A,B,C,Crest Factor A,B,C,
21/4/2020 10:13:17.647,0.00,60,207.846,207.845,207.846,207.846,207.845,207.846,0.0015717,0.000892723,0.000678978,120,120,120,120,120,5.74293e-05,0.00162913,0.000736408,0.0961562,0.0658469,0.0389105,0.00917411,0.00100751,-0.00516246,0.00012973,0.000672549,0.00066903,0.0115388,0.00790161,0.00466924,0,0,0,0.249016,0.199247,0.126655,0,0,0,
21/4/2020 10:13:17.748,0.101,60,207.845,207.846,207.847,207.845,207.846,207.847,0.000484911,0.000716525,0.000231614,120,119.999,120.001,120,119.999,120.001,0.000291418,-0.000193493,0.000523032,0.0963041,0.0660525,0.0392375,0.00873799,0.000840356,-0.0050699,0.000142419,0.000692023,0.000528912,0.0115565,0.0079262,0.00470855,0,0,0,0.245361,0.199247,0.126651,0,0,0,
21/4/2020 10:13:17.847,0.200,60,207.845,207.843,207.844,207.845,207.843,207.844,0.00195489,0.000834307,0.0027892,120,119.999,119.998,120,119.999,119.998,0.00201776,6.2867e-05,-0.00077144,0.0957361,0.0658142,0.0392642,0.00805068,0.000924351,-0.00582215,0.000124226,0.000720164,0.000534704,0.0114883,0.00789763,0.00471161,0,0,0,0.249,0.195608,0.128863,0,0,0,
21/4/2020 10:13:17.947,0.300,60,207.844,207.847,207.846,207.844,207.847,207.846,7.05616e-05,0.000486062,0.000556624,119.998,119.999,120.002,119.998,119.999,120.002,0.000496289,0.000425727,-6.03351e-05,0.0967671,0.0652786,0.0393575,0.00906719,0.000913487,-0.0051749,0.000184154,0.00060259,0.00057676,0.0116118,0.00783339,0.00472296,0,0,0,0.252638,0.192,0.126645,0,0,0,
```

Using Excel to select several measurement columns allows for easy plotting of trends. For example VLN for A, B and C (Y-axis) against no of samples (X-axis) as shown below.

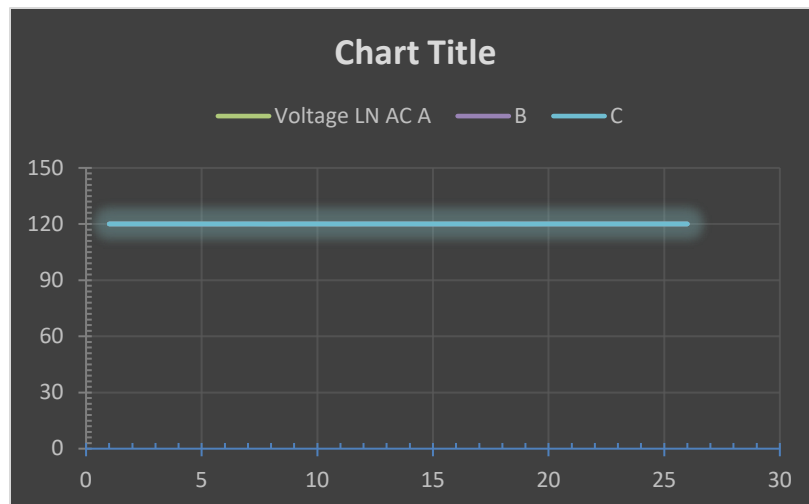

6.6 TRAN- TRANSIENTS Screens

Transient sequences allow precise time-controlled changes to be made to voltage (AC and DC mode) and frequency (AC mode only) under program control. A transient sequence consists of one or more list entries (or segments) that are executed in sequence.

There are three types of Transients modes:

- **LIST Mode**
- **STEP and RAMP Mode**
- **PULSE Mode**

Note that Step and Pulse transients can be accomplished using LIST mode as well but STEP and PULSE data entry is more intuitive.



Transients are created or edited in EDIT mode and can be saved to non-volatile memory as part of an instrument setup. They are executed in Execution mode.

The following sections cover all available transient modes.

6.6.1 LIST Mode

List mode is the most versatile transient data entry mode as it allows any of the other Transients types to be created as well. However, entering a long ramp or step transient consisting of many discrete steps in List mode is time consuming and tedious. It is also easier to make a mistake in LIST mode than using the STEP or RAMP mode. Same is true for PULSE transients which can be created with a short transient list as well.

LIST transients can be created from the front panel, using the LXI web server and a web browser or with Pacific's PPCS Manager Windows software.

An example Transient LIST created from the front panel is shown below.

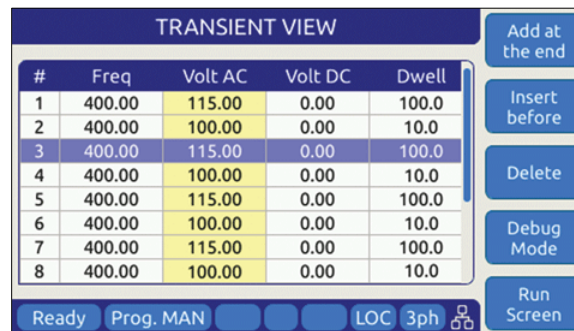

#	Freq	Volt AC	Volt DC	Dwell
1	400.00	115.00	0.00	100.0
2	400.00	100.00	0.00	10.0
3	400.00	115.00	0.00	100.0
4	400.00	100.00	0.00	10.0
5	400.00	115.00	0.00	100.0
6	400.00	100.00	0.00	10.0
7	400.00	115.00	0.00	100.0
8	400.00	100.00	0.00	10.0

6.6.2 LIST Parameters

The following parameters are available in each list transient list step.

PARAMETER	Range	Unit	Description
#	1 - 199	-	Displays the row number in the transient table. These numbers are generated automatically.
Ramp	0.2 - 9999	msec.	Ramp time to slew from existing set point to new set point value. Applies to both Frequency and Voltage. If previous set value is the same as new value, the value is not slewed but rather stays at the same value for the duration of the ramp time.
Frequency	16 – 1200	Hz	New frequency value
Voltage AC	0 – 300	V rms	New AC voltage value
Voltage DC	0 – 425	V dc	New DC voltage value
Dwell	0.2 - 9999	msec.	Dwell time. At the end of the ramp time, the new set values remain in effect during the dwell period. At the end of the dwell time, the next list entry (if any) will be executed.

Table 6-7: Available LIST Transient Parameters

Voltage LIST Transient Example 1

The table and associated figure below illustrates the operation of a transient. The blue line represents the RMS value of the phase A output voltage.

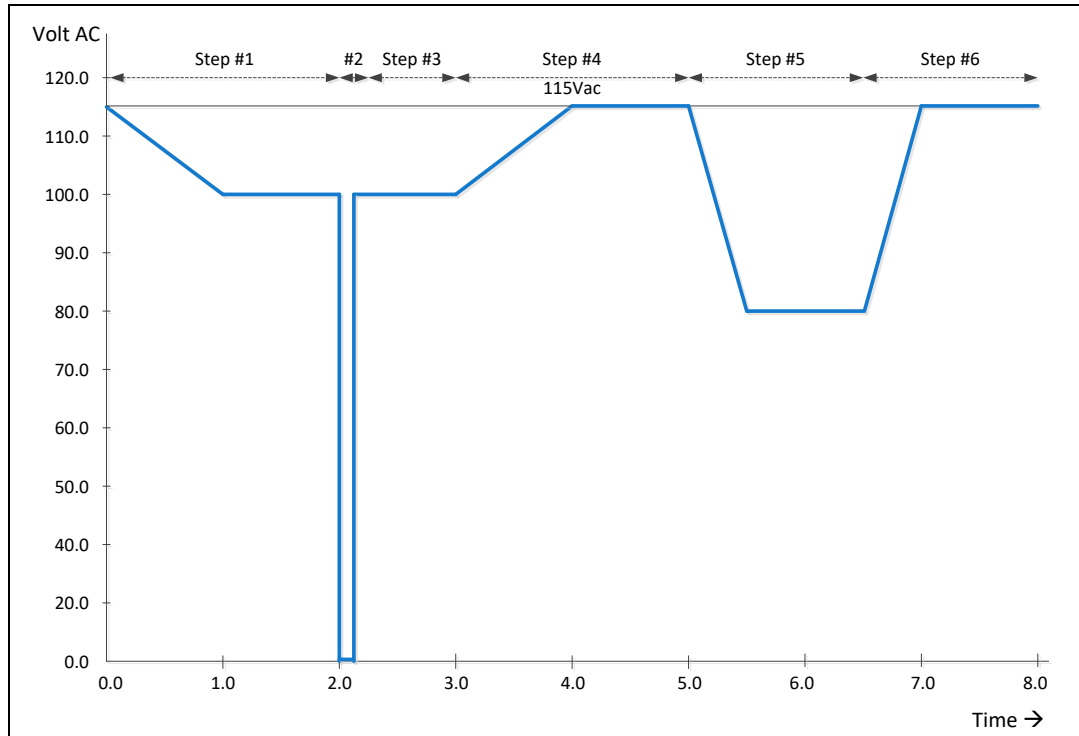

Figure 6-11: Voltage Transient Example 1

To generate this voltage versus time output sequence, the following transient list entries are required. (Ramp and dwell times shown in milliseconds using STEP mode.)

#	Ramp	Freq	Volt	Dwell
1	1000	400	100.00	1000
2	0.2	400	0.00	100
3	0.2	400	100.00	900
4	1000	400	115.00	1000
5	500	400	80.00	1000
6	0.5	400	115.00	1.00

Table 6-8: Voltage Transient List for Example 1

Voltage and Frequency LIST Transient Example 2

This example is based on an actual avionics test requirement from RTCA/DO160 Section 16 test number 16.5.2.1d. This is a single-phase abnormal voltage and frequency limit test for airborne equipment operated from 400Hz AC power.

The requirement from the test standard is shown in the table below:

TEST	VOLTAGE (V rms)	FREQUENCY (Hz)
1	122	430
2	100	430
3	122	370
4	100	370

Table 6-9: RTCA/DO160 Section 16 test number 16.5.2.1d

There are four tests, each runs for at least 5 minutes or 300 seconds. Each test step has a different voltage and frequency deviation from the nominal 115V and 400Hz. This is graphically illustrated by the image below.

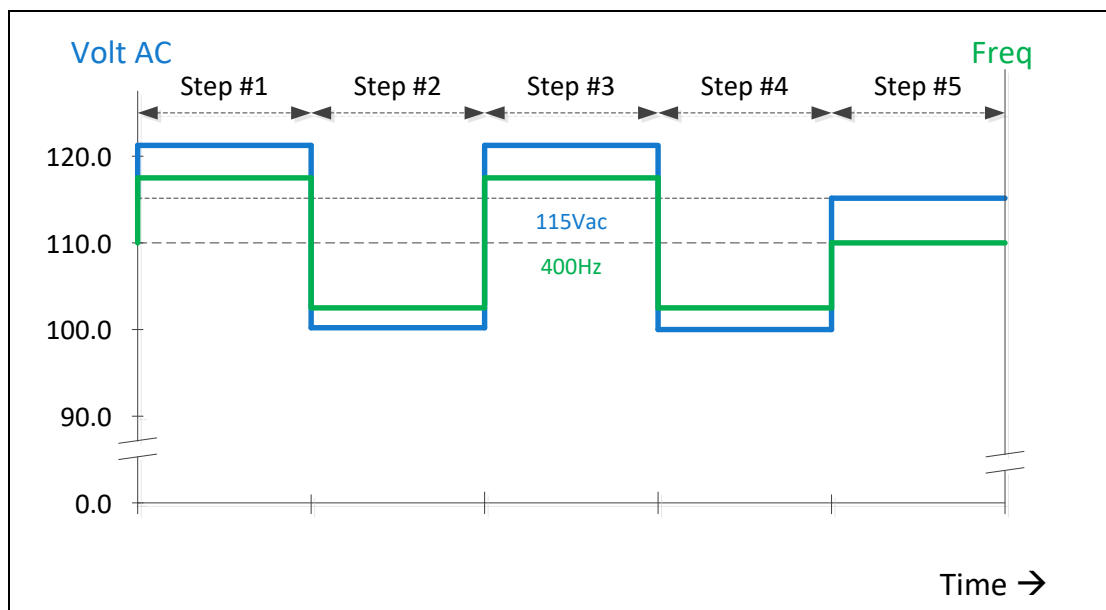

Figure 6-12: RTCA/DO160 Section 16 test number 16.5.2.1d

To generate this DO160 test sequence, the following transient list entries are required. Times shown in milliseconds.

#	Ramp	Freq	Volt	Dwell
1	0.2	430	122.00	300000
2	0.2	370	100.00	300000
3	0.2	430	122.00	300000
4	0.2	370	100.00	300000
5	1000	400	115.00	300000

Table 6-10: Voltage Transient List for Example 1

6.6.3 LIST Transient Edit Mode

To create a new transient program, press the **TRAN** key to select the Transient screen and then select the preferred data entry mode, LIST, STEP/RAMP or PULSE. If no transients have been entered or recalled, the initial screen will be blank.

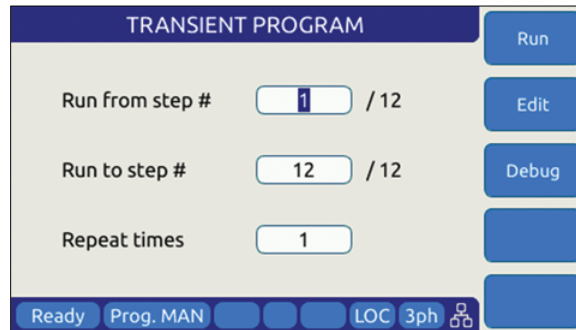

Figure 6-13: Blank TRANSIENT PROGRAM screen

The only available soft key is the “Create” key (SK1). Press the “Create” soft key to enter the Transient Edit mode. This will display the TRANSIENT VIEW screen.

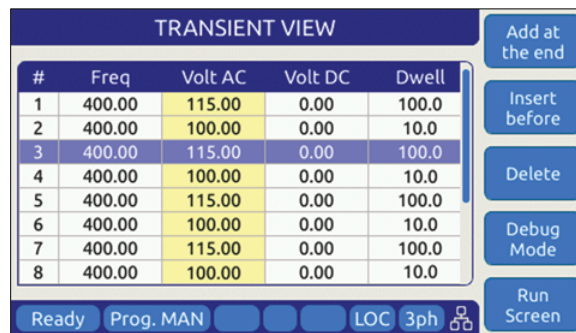

Figure 6-14: TRANSIENT VIEW Edit Mode

In Edit mode, a number of soft keys are available to aid in editing new or existing transient lists. They are defined in the following table.

SOFT KEY	Description
Add at the end (SK1)	Adds a new row entry at the bottom of the transient list table. If there are no table entries yet (new), pressing this key will add the first line of a new transient table.
Insert before (SK2)	Insert a new table row before the current selected row. The selected row and any rows below that are all pushed down one position.
Delete (SK3)	Deletes the current selected row. Any rows below the selected row are pushed up one position. Note: This action cannot be undone.

SOFT KEY	Description
Debug Mode (SK4)	Displays the Debug Execution mode screen. See section 6.6.4
Run Screen (SK5)	Returns to the regular TRANSIENT PROGRAM screen used for transient execution mode. See section 6.6.4.

Table 6-11: Available TRANSIENT EDIT screen soft keys

Once created, a transient sequence can be saved as part of the instrument setup. Refer to Section 6.7.4 for information on saving and recalling setups.

6.6.4 LIST Transient Execution Modes

Transients can be executed as soon as they have been entered. To execute a transient, the output **must be ON**. Sometimes it is best to debug a new transient sequence to make sure it performs the intended test and all values were entered correctly. To do so, the DEBUG mode is provided.

DEBUG MODE

The debug mode can be selected from the TRANSIENT VIEW screen by pressing the “Debug Mode” soft key (SK4). This changes the TRANSIENT VIEW screen from EDIT to DEBUG mode and displays a different set of soft keys to control execution.

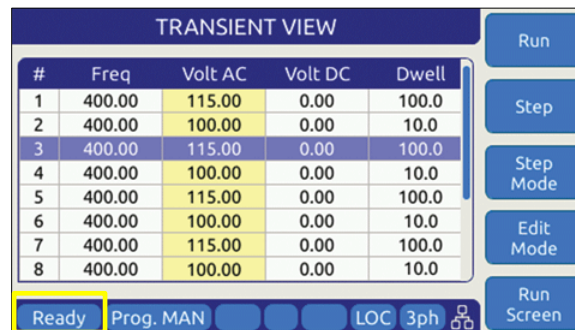

Figure 6-15: TRANSIENT Debug mode screen

The following execution control soft keys are available.

SOFT KEY	Description
Run (SK1)	Starts the transient from the currently selected row number
Step (SK2)	Single steps one row at a time
Step Mode (SK3)	Executes one step at a time
Edit Mode (SK4)	Stops execution and reverts to Edit mode
Run Screen (SK5)	Returns to the regular TRANSIENT PROGRAM screen used for transient execution mode. See section 6.6.4.

Table 6-12: Available TRANSIENT DEBUG screen soft keys

Note: The progress of the transient is indicated by the “Program” status bar at the bottom of the screen.

NORMAL EXECUTION MODE

Transient execution is controlled from the TRANSIENT PROGRAM screen. If no transient data has been entered, no run mode soft key will be visible. In that case, you must use the “Create” soft key to create a new transient sequence table.

The TRANSIENT PROGRAM screen for LIST mode is shown below.

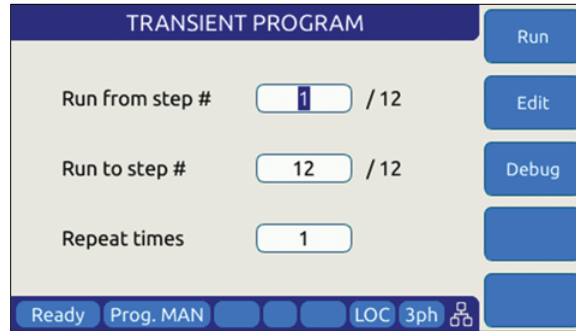

There are three user settable parameters that control execution of the transient sequence. They are:

1. Run from step #
2. Run to step #
3. Repeat times

Transients will be executed when the “Run” soft key (SK1) is pressed. If the output is **OFF** however, a message will appear indicating the output must be turned **ON** first.

The transient execution will start at the step # set and run until the Run to step value is reached. In the example above, from step #1 through step #6 inclusive.

The “Repeat times” field determines how many times the same sequence will be repeated. To run a sequence indefinitely or until manually stopped, use the shuttle to scroll down to zero or enter zero in this field using the keypad. This will set the repeat field to “indefinitely”.

The following soft keys are available on the TRANSIENT PROGRAM screen.

SOFT KEY	Description
Run (SK1)	Starts the transient from the “Run from step#” row number
Edit (SK2)	Displays the TRANSIENT VIEW edit mode screen. See section 6.6.3
Debug (SK3)	Displays the TRANSIENT VIEW debug mode screen.
Stop (SK4)	Only appears if “Repeat time” value is set to “indefinitely”. Press to stop execution manually

Table 6-13: Available TRANSIENT PROGRAM screen soft keys

6.6.5 LIST Transient Entry Modes

The AFX Series® supports two types of transient entry modes:

- LIST STEP Entry
- LIST SEGMENT Entry

Step mode is commonly used on AC and DC power sources that support the SCPI command language as the SCPI standard defines a LIST, STEP and PULSE command syntax.

Segment mode is used on all Pacific Power sources with UPC controllers such as ASX and AMX Series. Both modes support the same capabilities however.

Note that in STEP mode, two segment entries are combined so each STEP mode entry requires two SEGMENT entries. The two transient examples below represent the same transient display in either mode.

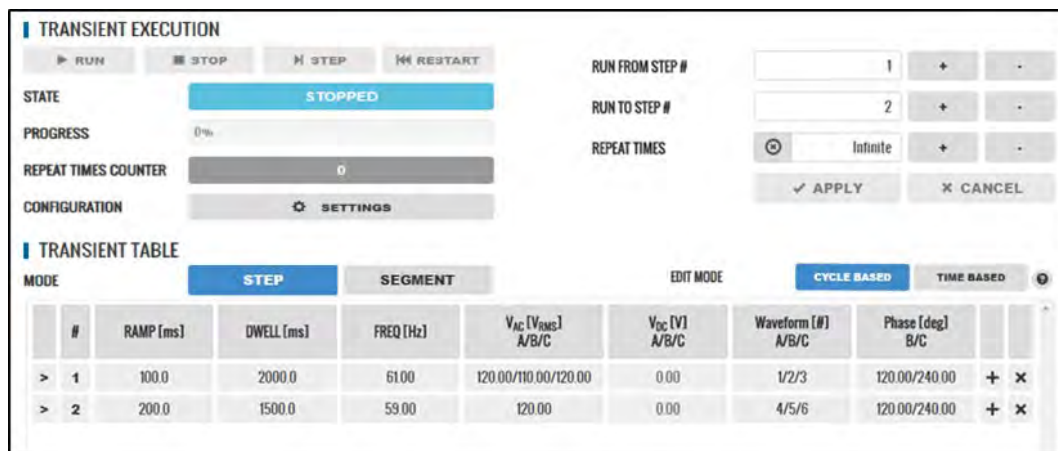

Figure 6-16: Transient shown in STEP Entry Mode

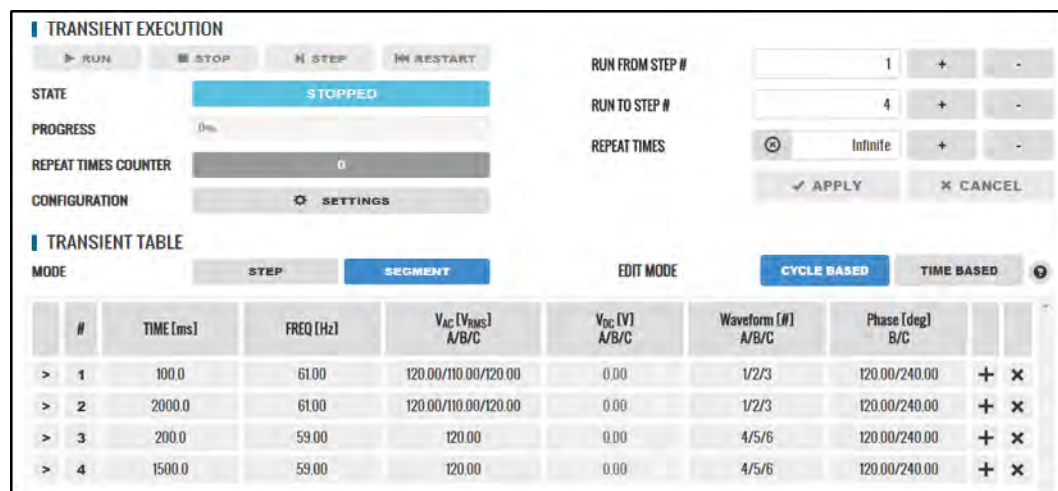

Figure 6-17: Transient shown in SEGMENT Entry Mode

6.6.6 Multiple User Waveforms in LIST Transients

Transient programs are very useful to deliver precisely controlled transitions between different waveforms to a unit under test. This means transitions from a normal AC sine wave to a non-sinusoidal or distorted waveform can be accomplished by using different waveform at different segment or step entries.

Waveforms are numbered from 1 through 200 with 1 being a fixed sine wave. All other waveform registers are user defined arbitrary waveforms.

When in AC mode, transient segments or steps can called out different waveform numbers on each of up to three phases⁵. For each segment, up to six different waveforms can be selected. The same waveform can be repeated as of often as needed within the same transient program.

In three or split phase mode, each phase in a transient program can use its own set of up to six user-defined waveform. Thus, up to 18 different waveforms are available when in three-phase mode.

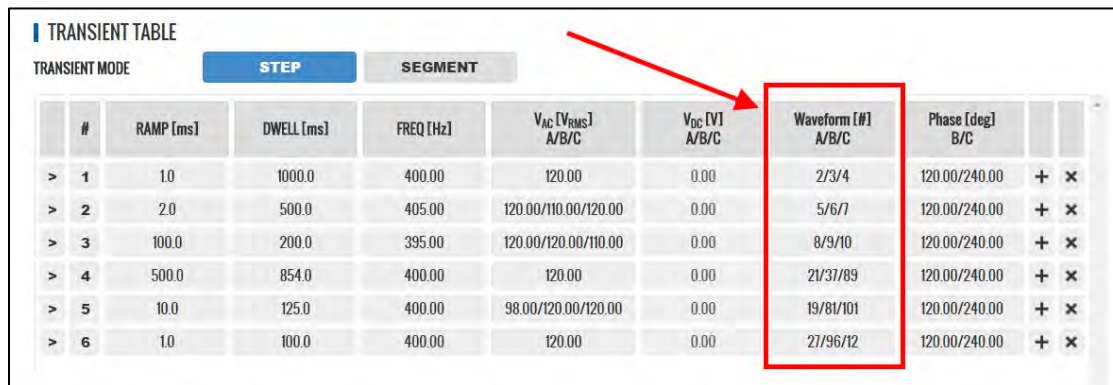

TRANSIENT TABLE									
TRANSIENT MODE									
STEP									
SEGMENT									
#	RAMP [ms]	DWELL [ms]	FREQ [Hz]	V _{AC} [V _{RMS}] A/B/C	V _{DC} [V] A/B/C	Waveform [#] A/B/C	Phase [deg] B/C		
> 1	1.0	1000.0	400.00	120.00	0.00	2/3/4	120.00/240.00	+	×
> 2	2.0	500.0	405.00	120.00/110.00/120.00	0.00	5/6/7	120.00/240.00	+	×
> 3	100.0	200.0	395.00	120.00/120.00/110.00	0.00	8/9/10	120.00/240.00	+	×
> 4	500.0	854.0	400.00	120.00	0.00	21/37/89	120.00/240.00	+	×
> 5	10.0	125.0	400.00	98.00/120.00/120.00	0.00	19/81/101	120.00/240.00	+	×
> 6	1.0	100.0	400.00	120.00	0.00	27/96/12	120.00/240.00	+	×

Figure 6-18: Available User Waveforms in Transients

⁵ Requires Front Panel Firmware revision 1.3.3.

6.6.7 STEP or RAMP Modes

STEP and RAMP transients are very similar except in RAMP data entry mode, each step duration is set to the minimum available time interval of 0.2 msec to obtain the smoothest possible ramp result.

In STEP mode, the user sets each increment/decrement and step dwell time.

Step transients are useful for testing over or under voltage protection circuits on AC or DC input supplies. They allow Voltage (AC or DC), Frequency and phase B or C to be steps at discrete intervals and times. An example STEP transient is shown in the screen capture below. It shows the relationship between the RAMP Parameters.

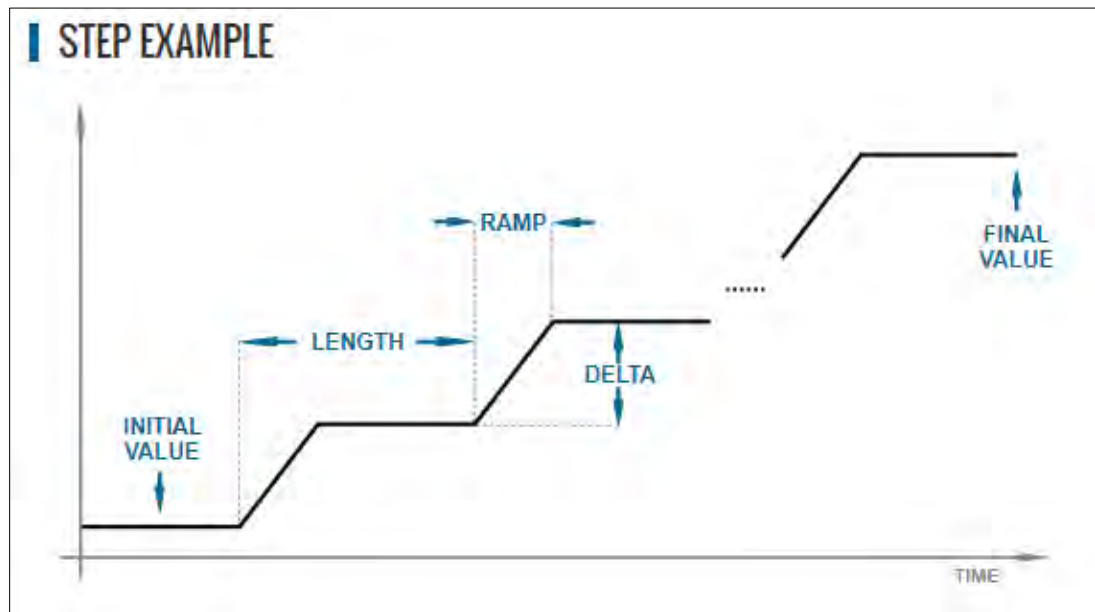

The LENGTH is the dwell time for each step level, including any ramp time. The first step starts from the INITIAL VALUE. The DELTA is the increment or decrement value for each step. The FINAL VALUE determines how many steps will be required to reach it.

Thus, the step COUNT will be:

$$\text{COUNT} = (\text{FINAL VALUE} - \text{INITIAL VALUE}) / \text{DELTA}$$

The total duration to complete the STEP transient depends on the repeat setting, length and if the Insert Initial Value check box is ON or OFF:

If Insert Initial Value = ON (default):

$$\text{DURATION} = \text{REPEAT TIMES} * (\text{COUNT} + 1) * \text{LENGTH}$$

If Insert Initial Value = OFF:

$$\text{DURATION} = \text{REPEAT TIMES} * \text{COUNT} * \text{LENGTH}$$

Step Transients can be programmed from the front panel or the LXI webserver.

6.6.8 STEP or RAMP Parameters

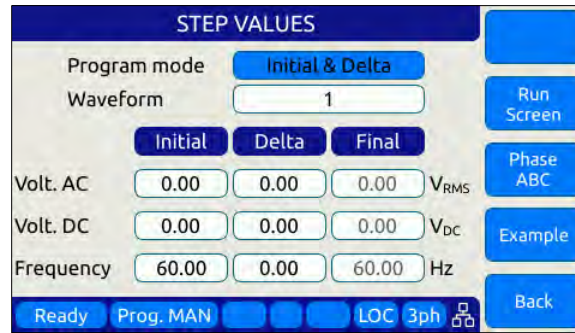

Step transients can be used to create discrete stair step like voltage and/or frequency changes or smooth ramps. The default ramp time is 0.2 msec.

Ramps can be programmed in three modes:

- INIDEL (0): Initial & Delta: Programmed by initial and delta values
- FINDEL (1): Final & Delta: Programmed by final and delta values
- INIFIN (2): Initial & Final: Programmed by initial and final values

Step transients can be used to step frequency, voltage AC, voltage DC, and phases.

The HOLD is ON, the last step values will be set as steady-state when the step execution ends. Duration of each step is determined by: $LENGTH = WIDTH + RAMP TIME$

The following parameters are available in a STEP VALUES screen.

PARAMETER	Range	Unit	Description
Program Mode	Initial & Delta Final & Delta Initial & Final	-	Program Entry Modes
Waveform	1 ~ 200		Waveform number
Voltage AC	0 ~ 300	Vrms	AC Voltage
Voltage DC	-425 ~ + 425	Vdc	DC Voltage
Frequency	15 ~ 1200	Hz	Frequency

Table 6-14: Available STEP Transient Parameters

The following soft keys are available on the STEP PROGRAM screen.

SOFT KEY	Description
(SK1)	
Run Screen(SK2)	Displays the STEP EXECUTION screen.
Phase ABC (SK3)	Toggles between phase A, B, C or Coupled ABC
Example (SK4)	Displays a graphical representation of the STEP parameters
Back (SK5)	Returns to previous screen

Table 6-15: Available STEP PROGRAM screen soft keys

6.6.9 STEP or RAMP Transient Execution Modes

STEP Transients can be executed as soon as they have been entered. To execute a transient, the output **must be ON**.

STEP or RAMP Transient execution is controlled from the STEP EXECUTION screen. If no STEP or RAMP transient data has been entered, no run mode soft key will be visible. In that case, you must back up to the STEP VALUES screen.

The STEP EXECUTION screen is shown below.

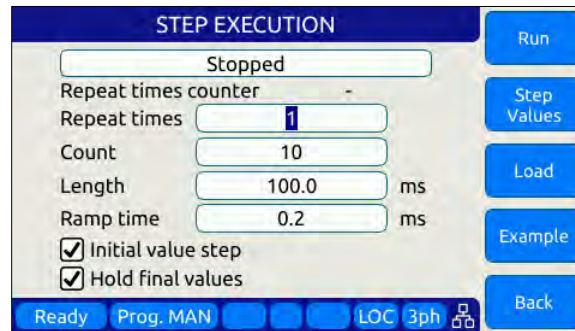

For STEP transients, Count and Length as well as Ramp time are available to be set. The “Hold final values” checkbox determines if the final state after the ramp completes remains at the final ramp values or returns the to settings before the ramp was executed.

Transients will be executed when the “Run” soft key (SK1) is pressed. If the output is **OFF** however, a message will appear indicating the output must be turned **ON** first.

The “Repeat times” field determines how many times the same STEPS or RAMPS will be repeated. To run a sequence indefinitely or until manually stopped, use the shuttle to scroll down to zero or enter zero in this field using the keypad. This will set the repeat field to “indefinitely”.

The “Count” field specifies how many steps will be taken and

The following soft keys are available on the STEP PROGRAM screen.

SOFT KEY	Description
Run (SK1)	Starts the transient from the “Run from step#” row number
Step Values (SK2)	Displays the STEP VIEW edit mode screen.
Load (SK3)	Converts STEP transient definition to standard transient segments
Example (SK4)	Displays a graphical representation of the STEP parameters
Back (SK5)	Returns to previous screen

Table 6-16: Available STEP EXECUTION screen soft keys

6.6.10 PULSE Mode

PULSE transient mode provides a quick and easy way to enter repetitive pulsed output events. This applies to AC voltage, DC voltage and or Frequency. A sample of a PULSE transient definition is shown in the screen capture below.

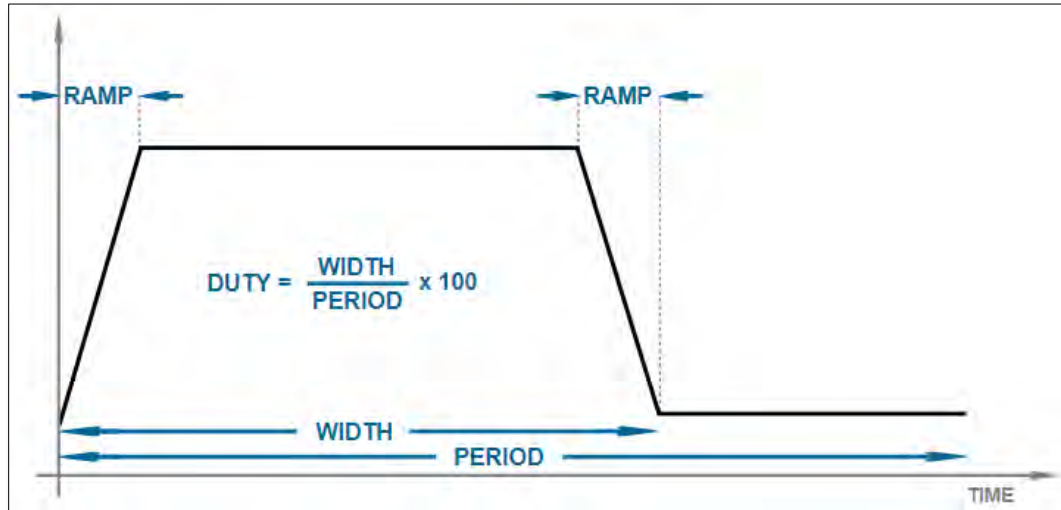

The parameters that define a PULSE transient are dependent of each other so changing one may force another to change. The semantics used for setting PULSE transients is as follows:

Parameter	Description
RAMP	Up or down ramp time
WIDTH	Duration of pulse including rising and failing ramp times
PERIOD	Total time duration for a single pulse
DUTY	Duty cycle of the pulse

The DUTY cycle is determined by the other three parameters as in:

$$DUTY = WIDTH \times 100 / PERIOD$$

6.6.11 PULSE Parameters

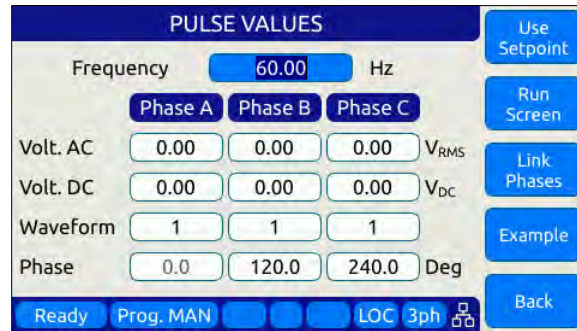

Pulse transients can be used to create repetitive events for endurance testing of AC and DC powered products.

The following parameters are available in a PULSE VALUES screen.

PARAMETER	Range	Unit	Description
Frequency	15 ~ 1200	Hz	Frequency
Voltage AC	0 ~ 300	Vrms	AC Voltage
Voltage DC	-425 ~ + 425	Vdc	DC Voltage
Waveform	1 ~ 200		Waveform number
Phase	0.0 ~ 359.9	Deg	Phase angle for phases B & C

Table 6-17: Available STEP Transient Parameters

The following soft keys are available on the PULSE VALUES screen.

SOFT KEY	Description
Use Setpoint (SK1)	Starts the transient from the “Run from step#” row number
Run Screen(SK2)	Displays the PULSE EXECUTION screen.
Link Phases (SK3)	Toggles between phase A, B, C or Coupled ABC
Example (SK4)	Displays a graphical representation of the STEP parameters
Back (SK5)	Returns to previous screen

Table 6-18: Available STEP PROGRAM screen soft keys

6.6.12 PULSE Transient Execution Modes

PULSE Transients can be executed as soon as they have been entered. To execute a transient, the output **must be ON**.

PULSE transient execution is controlled from the PULSE EXECUTION screen. If no PULSE transient data has been entered, no run mode soft key will be visible. In that case, you must back up to the PULSE VALUES screen.

The PULSE EXECUTION screen is shown below.

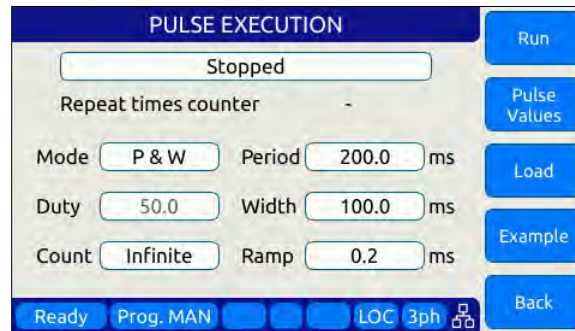

For PULSE transients, there are three user settable parameters that control execution of the transient sequence. They are:

- P&W (0): Programmed by Period & Width
- P&D (1): Programmed by Period & Duty Cycle
- W&D (2): Programmed by Width & Duty Cycle

Depending on the data entry mode selected, one of the data entry fields will be disabled and calculated based on the other parameter settings.

Transients will be executed when the “Run” soft key (SK1) is pressed. If the output is **OFF** however, a message will appear indicating the output must be turned **ON** first.

The “Count” field determines how many pulses will be run. To run a sequence indefinitely or until manually stopped, use the shuttle to scroll down to zero or enter zero in this field using the keypad. This will set the repeat field to “Infinite”.

The following soft keys are available on the PULSE PROGRAM screen.

SOFT KEY	Description
Run (SK1)	Starts the transient from the “Run from step#” row number
Pulse Values (SK2)	Displays the PULSE edit mode screen.
Load (SK3)	Converts PULSE transient definition to transient segments
Example (SK4)	Displays a graphical representation of the PULSE parameters
Back (SK5)	Returns to previous screen

Table 6-19: Available STEP PROGRAM screen soft keys

6.6.13 AUTO RMS Function – Transients

The AUTO RMS mode⁶, if enabled, causes all transient voltages to be calculated as true RMS voltage of the waveforms used in any Segment of the Transient. This means the output voltage RMS level will remain the same, regardless of the wave shape.

When disabled, RMS calculation of substituted waveforms does not occur. Disabling AUTO RMS facilitates constant amplitude transients such as partial cycle dropouts or sub-cycle spike transients.

This mode is set by sending the **PROGram:TRANSient:AUTORMS** command over one of the Digital control interfaces.

Note: In UPC Compatibility mode, this mode is always enabled but applies to steady state only.

⁶ Requires Front Panel Firmware revision 1.3.3.

6.7 CONF – CONFIGURATION Screens

The CONFIGURATION screens 1 & 2 allow setting of secondary parameters functions. These include the following operation aspects:

- Configuration

Pressing the **CONF** key will display the CONFIGURATION screen as shown on the left below. If the master unit is an AFXT model, the transformer coupled output mode selection will be displayed at the bottom of the configuration screen. If the master unit is an AFXS model, the Series connection will be displayed instead.

The image displays four screenshots of the configuration screens, connected by arrows indicating the navigation flow.

UNIT CONFIGURATION 1 OF 2 (Top Left): Shows settings for Form (Three (ABC)), Voltage range (High), Mode (AC+DC), Update phase (0.00 Deg), Output disable phase (0.00 Deg), and Coupling (XFMR (400V)). Navigation buttons include User Limits, Ramp & Slew, Program Memory, CSC Config., and Next Screen.

UNIT CONFIGURATION 1 OF 2 (Bottom Left): Shows settings for Form (Three (ABC)), Voltage range (High), Mode (AC+DC), Update phase (0.00 Deg), Output disable phase (0.00 Deg), and Series connection (OFF). Navigation buttons include User Limits, Ramp & Slew, Program Memory, CSC Config., and Next Screen.

USER LIMITS (Top Right): Shows settings for Voltage AC (0.00 to 600.00 V_{RMS}), Voltage DC (-425.00 to 425.00 V_{DC}), and Frequency (15.00 to 1200.00 Hz). Navigation buttons include Apply, Cancel, and Back.

RAMP TIME & SLEW RATE (Middle Right): Shows Ramp time (Disabled ms) and Slew rate control (active). Settings include Voltage AC (10.00 V_{RMS}/ms), Voltage DC (10.00 V_{DC}/ms), Frequency (5.00 Hz/ms), and Phase (5.00 Deg/ms). Navigation buttons include Apply All, Cancel All, Enable Ramp T., Enable Slew R., and Back.

PROGRAM MEMORY (Bottom Right): Shows Current program register # (MANUAL) and Manual input field. Settings include Recall from register # (1), Save setup to register # (1), and Power-on recall register # (Disabled). Navigation buttons include Browse, Recall, Save, Set, Refresh, and Back.

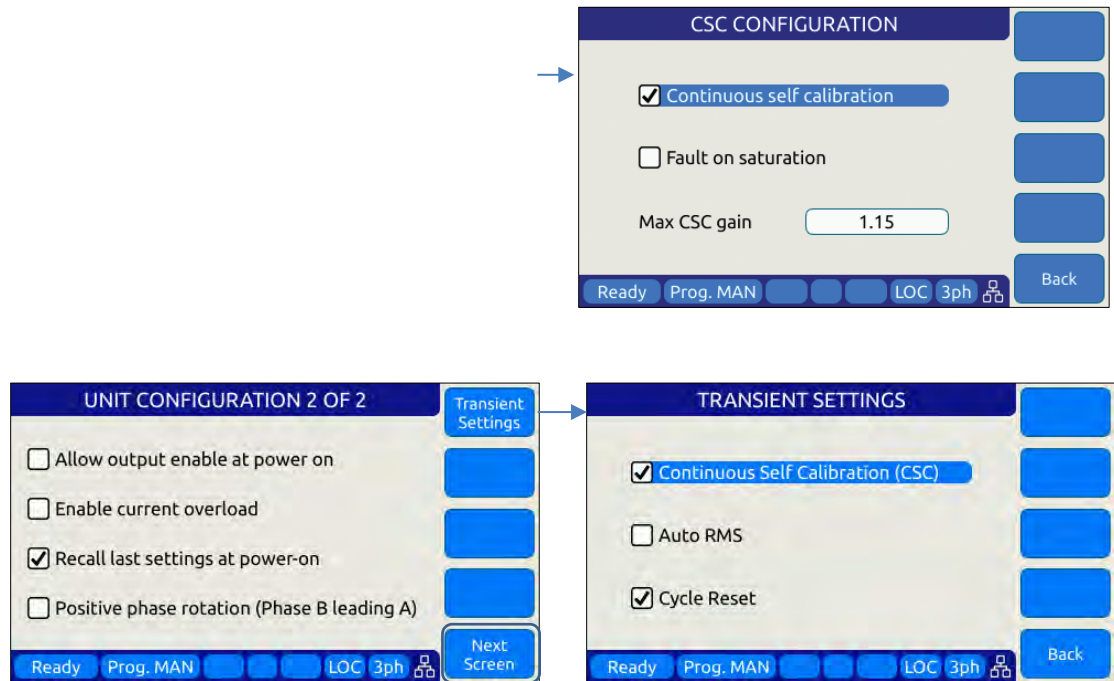

All other system related screens can be accessed using the SYST menu key. (Refer to Section 6.7.7).

6.7.1 UNIT CONFIGURATION Screens

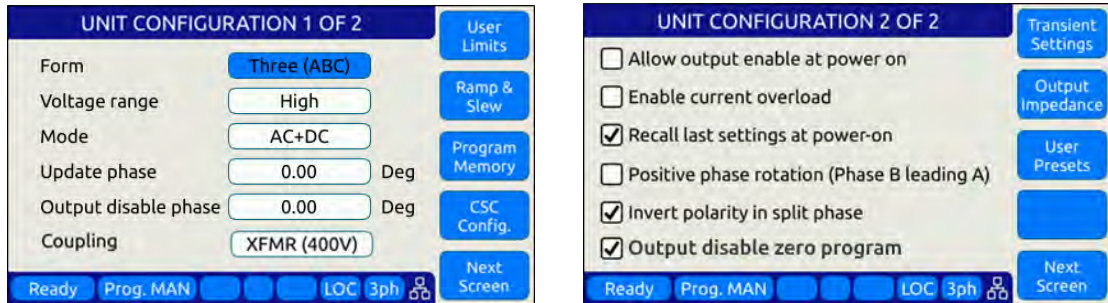

The following settings can be changed from the UNIT CONFIGURATION screens:

UNIT CONFIGURATION 1 OF 2-----

Form This field determines the phase mode of operation. Available settings are One, Split or Three. Note that for one phase mode, it is necessary to short the three output phases together using the optional single-phase output connector accessory. Alternatively, the user can use an external terminal block to tie the three phase outputs together.

Note: When switching from one phase to three or split phase modes, a warning will be displayed to make sure the end-user removes any common connections between the three outputs.

Voltage Range Although the power source uses a constant power mode voltage range to allow operation using a single 300Vac/425Vdc voltage range only, the end user can simulate a low voltage range by setting this field to Low. Doing so limits programming of any output voltage to no more than 150Vac/212Vdc or half the available voltage range of the power source. If operation to 300Vac/425Vdc is desired, this field should be set to High. This effectively simulates a conventional dual voltage range model.

Mode Sets the output mode to, AC, DC or AC+DC.

Update Phase Sets the phase angle at which output voltage and frequency changes will take place on phase A. This setting applies to both steady state output changes and to the start of a transient program execution. It also applies to the OUTPUT ENABLE and DISABLE function key on the front panel. Changes on phases B and C will take place at the same moment in time but at phase angles that are shifted from phase A by the phase angles programmed for phase B and C.

Output Disable Phase

This setting determines if the output off event at a specific phase angle of phase A voltage or randomly when ever the user presses the Output On/Off button or sends an output off command.

Coupling

This field selects the output coupling mode of the power source. Unless an optional output transformer is installed with the power source (T Option), this field is always fixed to DIRECT. Direct coupling output mode supports either AC mode, DC mode or a combination of AC and DC output to be programmed. If the optional transformer is installed, the AFX model number will show “AFXT” to indicate the presence of the output transformer. To use the output transformer coupled range, selected XFMR (xxxV) in this field. The voltage indication may vary based on the transformer ration of the installed output transformers.

Note: While in XFMR coupled mode, only **AC** voltage programming is possible.

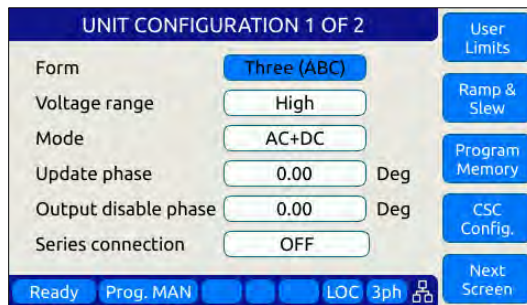

Series Connection

Series connection selection is only available on AFX units that are equipped with the Series Output mode option. These units will have an “S” appended after the AFX models numbe as in “AFXS”. This filed replaces the Coupling Field. If the Series/Parallel Mode Swicth option is present in the AFXS system, the field can be used to switch between Paralllel Output Mode or Series Output Mode. If the SPMS option is not present, the AFXS system is hardwired for Series output mode only and this field will show ON and is disabled.

In Series Output Mode, the output voltage range is two times the standard voltage range. Only available on multiples of two AFX units.

Access to other utility screens is available from the UNIT CONFIGURATION screen through the soft keys. The table below lists the available soft keys on the UNIT CONFIGURATION screen.

SOFT KEY	Description
User Limits (SK1)	Displays SETUP MENU screen. Refer to section 0
Ramp & Slew (SK3)	Displays SLEW RATE MENU screen. Refer to section 6.7.3
Program Memory (SK2)	Displays PROGRAM MEMORY screen. Refer to section 6.7.4
CSC Config. (SK4)	Display CSC setting screen
Next Screen (SK5)	Toggle to alternate UNIT CONFIGURATION screen

Table 6-20: Available UNIT CONFIGURATION 1 screen soft keys

UNIT CONFIGURATION 2 OF 2 -----

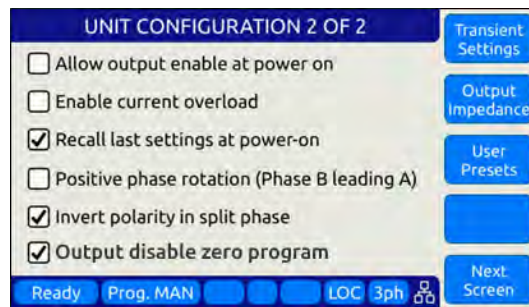

Allow output enable at power on This mode if set, causes the output to turn on at power up.

Enable Current Overload Current Overload mode allows the power source to provide more than the nominal max. RMS current (around 30 percent more) for a short period (up to 2 seconds). When enabled, the user can set the CURR:LIM 30% higher than what this mode off. For example in a stand-alone 3150AFX unit in three phase mode (FORM 3), RMS output current can be up to 55A when the continuous output limit is 41.7A. A warning message will be display notifying the user this mode is being enabled.

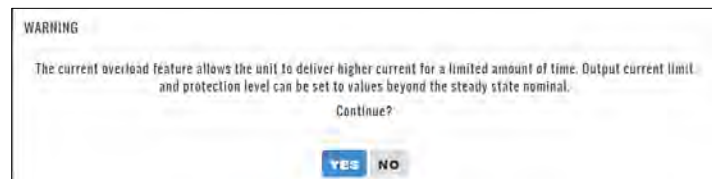

Recall last settings at power-on When checked, this mode will cause the last settings that were in effect when the power source was last turned off to be recalled at power on. This allows a user to resume operation without having to set up again between power on/off events.

Positive phase rotation When checked, the phase rotation in three phase mode will be set to A -> C -> B corresponding to positive phase

- rotation for three phase AC motors. To select negative phase rotation, uncheck this option.
- Invert polarity in split phase** When checked, the AC waveform in split-phase mode of operation is shifted 180° (inverted).
- Output disable zero program** When checked, the programmed voltage is first set to zero voltage when pressing the Output Enable button or executing the OUTP OFF command. This allows any energy stored in the EUT to dissipate into the low impedance output of the power source before the relay disconnects the load.

Access to other utility screens is available from the UNIT CONFIGURATION screen through the soft keys. The table below lists the available soft keys on the UNIT CONFIGURATION screen.

SOFT KEY	Description
Transient Settings (SK1)	Display Transient Configuration Settings
Output Impedance (SK2)	Program Output Impedance R and L values.
User Presets (SK3)	Access to user defined preset value settings for output programming soft keys
Next Screen (SK5)	Toggle to alternate UNIT CONFIGURATION screen

Table 6-21: Available UNIT CONFIGURATION 2 screen soft keys

6.7.2 USER LIMITS SETTINGS Screen

This screen allows programming user defined voltage and frequency upper and lower limits to prevent an operator from accidentally programming output settings that could be damaging to a unit under test.

For example, when testing a 50 Hz transformer, a lower frequency limit setting of 47 would prevent output frequency programming of values that could cause the transformer to saturate.

The same applies to voltage where a high voltage value could damage a unit under test that was not designed to handle a high AC or DC input voltage.



Figure 6-19: USER LIMIT SETTINGS Screen

The following parameters can be set from this screen:

- Voltage AC** Lower and Upper Vrms set limits for AC programming.
- Voltage DC** Lower and Upper Vdc set limits for DC programming.
- Frequency** Lower and Upper limits for Frequency programming.

The soft keys on the USER LIMITS SETTINGS screen provide access to additional functionality as listed in the table below.

SOFT KEY	Description
Apply (SK1)	Accepts new settings and returns to previous screen.
Cancel (SK2)	Returns to the previous screen.
-	
-	
Back (SK5)	Returns to the previous screen.

Table 6-22: Available USER LIMITS SETTINGS screen soft keys

6.7.3 RAMP TIME & SLEW RATE SETTINGS Screen

This screen allows programming of the update ramp time or individual voltage and frequency slew rates, which are applied when changing output settings. Ramp time and slew rate settings are mutually exclusive so Ramp time must be disabled in order to program individual voltage, frequency and phase update rates. Setting a slew rate other than the maximum value allows voltage and frequency changes to occur at a controlled rate of change. The Ramp time when enabled applies to any setting change equally.

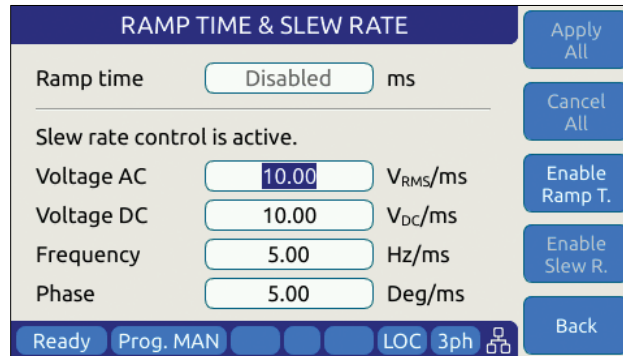

Figure 6-20: RAMP TIME & SLEW RATE SETTINGS Screen

The following parameters can be set from this screen:

Ramp time	Sets the time over which output changes will take place. For the time set, output changes will ramp from their previous set value to the new set value. When DISABLED , changes will occur at the programmed slew rate settings in the SLEW RATE SETTING screen, as both cannot be in effect at the same time. Settings Slew Rate settings provide control over individual parameters whereas the RAMP TIME setting applies to all parameters (F, Vac, Vdc and Phase) changes equally.
Voltage AC	AC Voltage slew rate in Vrms per msec. Available range is 0.01 Vrms/ms through 300 Vrms/ms.
Voltage DC	DC Voltage slew rate in Vdc per msec. Available range is 0.01 Vdc/ms through 850 Vdc/ms.
Frequency	Frequency slew rate in Hz per msec. Available range is 0.01 Hz/ms through 1200 Hz/ms.
Phase	Phase angle slew rate in Degrees per msec. Available range is 0.01 Deg/ms through 359.91 Deg/ms

NOTE: Programmed Slew Rate settings will only take effect when the RAMP TIME setting is **DISABLED**.

The soft keys on the SLEW RATE SETTINGS screen provide access to additional functionality as listed in the table below.

SOFT KEY	Description
Apply All (SK1)	Applies all changes made (highlighted in grey) and returns to previous screen.
Cancel All (SK2)	Cancels all changes (highlighted in grey), sets slew rates back to prior settings and returns to previous screen.
Enable Ramp T.	Enables Ramp time, disables Slew rate settings
Enable Slew R.	Enable Slew Rate settings, disables Ramp time
Back (SK5)	Returns to the previous screen.

Table 6-23: Available RAMP TIME & SLEW RATE SETTINGS screen soft keys

6.7.4 PROGRAM MEMORY Screen

The Program Memory menu allows saving and recalling of instrument setups in non-volatile memory registers. Setups include all steady state parameters, limits, operating modes and transient list if programmed.

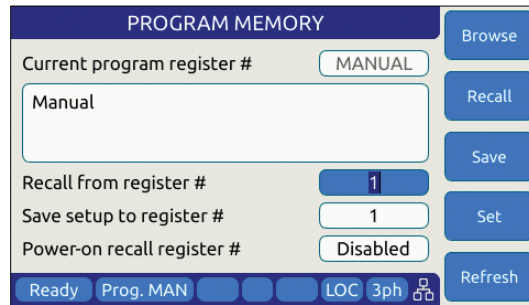

Figure 6-21: PROGRAM MEMORY screen

There are 10 setup registers numbered from 1 through 10. Use the shuttle to select either the Recall or Save field and press the shuttle to enter edit mode. Once the correct number is selected, press ENTER to confirm.

Recall from register #

Recalls setup from selected register. If register is empty, an error message will be displayed and no setting will be recalled.

Note: If a register location is empty, an error message will be displayed.

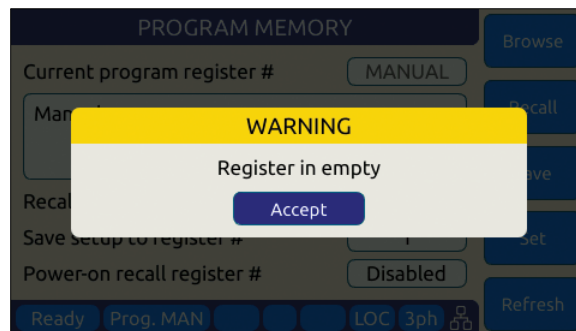

Save setup to register #

Saves setup in effect to selected register number. If this register already contained a saved setup, it will be overwritten.

Power recall register #

Determines which register number setup is recalled at power-up. Using this feature, the user can determine the power-on default settings of the power source.

The soft keys on the PROGRAM MEMORY screen provide access to additional functionality as listed in the table below.

SOFT KEY	Description
Browse(SK1)	Allows browsing for a particular register’s content.
Recall (SK2)	Recalls selected Register setup content
Save (SK3)	Saves setup to selected Register
Set (SK4)	Sets output to selected Register content
Refresh (SK5)	Return to previous screen

Table 6-24: Available SLEW RATE SETTINGS screen soft keys

6.7.5 CSC CONFIGURATION Screen

The CSC CONFIGURATION menu allows the Continuous Self Calibration mode to be enabled. This feature is used to improve load regulation of the power source by continuous measurement of the output phase voltage(s) and adjusting the internal set points as needed to maintain close to zero load regulation. If the CSC is unable to get the output to the set point, an error will be generated. This error can be disabled by unchecking the “Fault on saturation” check box.

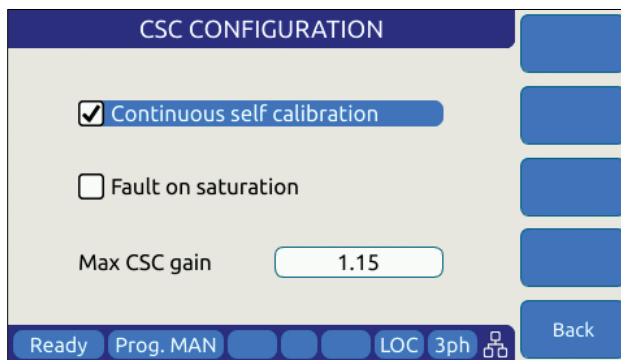

Figure 6-22: CSC CONFIGURATION screen

The soft keys on the CSC CONFIGURATION screen are listed in the table below

SOFT KEY	Description
-	
-	
-	
-	
Back (SK5)	Return to previous screen

Table 6-25: Available CSC CONFIGURATION screen soft keys

6.7.6 TRANSIENT SETTINGS Screen

The TRANSIENT SETTINGS screen defines operation of transient execution.

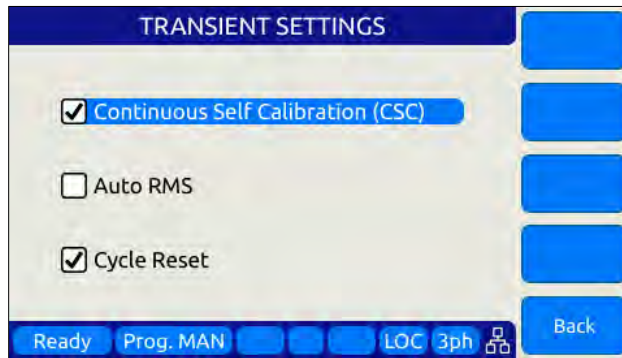

Available settings are:

- Continuous Self Calibration** This CSC mode is similar to the CSC mode for steady state operation but applies to transient mode.
- Auto RMS** This field allows enabling or disabling of the Auto RMS mode for transient mode operation. Refer to section 6.6.13, “AUTO RMS Function – Transients” for further details.
- Cycle Reset** When enabled, the CYCLE RESET mode will cause repeated executions of the transient as determined by the repeat count or the continuous execution setting to re-sync to the start phase angle set for the start of each transient. When disabled, repeats of the transients start immediately after the previous execution completes with no resync. With Cycle Reset on, there may be up to one period of the AC frequency of delay added between successive runs.
Note: In UPC Compatibility mode, Cycle Reset is default on.

The soft keys on the TRANSIENT SETTINGS screen are listed in the table below

SOFT KEY	Description
-	
-	
-	
-	
Back (SK5)	Return to previous screen

Table 6-26: Available TRANSIENT SETTINGS screen soft keys

6.7.7 OUTPUT IMPEDANCE Screen

The OUTPUT IMPEDANCE screen allows the output impedance of the power source to be programmed.



Following parameters can be set from this screen:

Mode: Selects between Real time or RMS mode.

- **Real time:** Real-time mode uses a fast responding method to control output impedance. This mode is faster but has a more limited programming range. It works at the signal level implanting a digital filter, equivalent to a resistor and an inductor, in series with the output. It emulates a phase shift and waveform distortion similar to an actual LR impedance at frequencies within the bandwidth of the output amplifier (around 3kHz). CSC must be disabled to use this mode.
- **RMS:** RMS Mode is slower as it relies on the measured RMS output voltages and currents to make adjustments, but it has a wider programming range. It is based on steady state RMS measurements, not on real-time signals, so it does not affect output waveform and phase shift. It allows higher impedance ranges while keeping the output stable. It also allows the CSC mode to remain enabled, so at a steady state level it provides a very accurate voltage drop (on an RMS measurement level).

Resistance: Sets the Resistive value for the programmable impedance.

Impedance: Sets the Inductive value for the programmable impedance.

The soft keys on the OUTPUT IMPEDANCE screen are listed in the table below

SOFT KEY	Description
-	
-	
-	
-	
Back (SK5)	Return to previous screen

Table 6-27: Available PROGRAMMABLE IMPEDANCE screen soft keys

6.7.8 USER PRESETS Screen

The USER PRESETS screen allows the soft key set values for output programming that appear in the PROGRAM screen to be changed to setting values preferred by the user.

Presets can be defined for the following output settings:

- VOLTage[:AC]
- VOLTage:DC
- FREQuency
- PHASe
- CURRent:LIMit
- POWer:LIMit
- KVA:LIMit

6.7.8.1 AC and DC Voltage Soft keys



SK #	Value	Unit
SK #1	115.00	V _{RMS}
SK #2	20.00	V _{RMS}
SK #3	300.00	V _{RMS}
SK #4	MAX 300.00	V _{RMS}

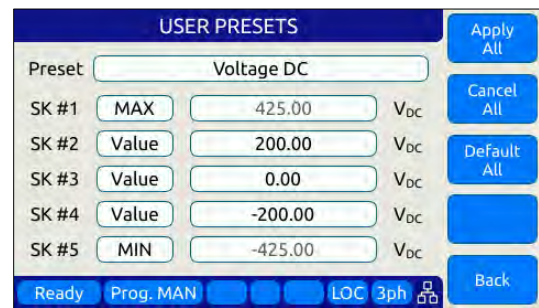

SK #	Value	Unit
SK #1	MAX 425.00	V _{DC}
SK #2	Value 200.00	V _{DC}
SK #3	Value 0.00	V _{DC}
SK #4	Value -200.00	V _{DC}
SK #5	MIN -425.00	V _{DC}

6.7.8.2 Frequency and Phase Soft keys

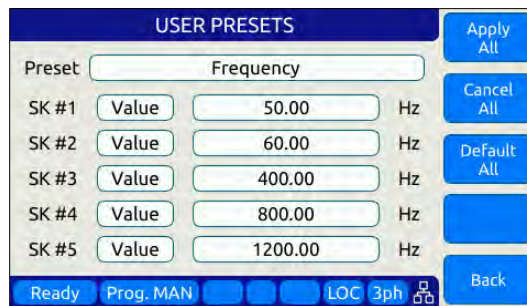

SK #	Value	Unit
SK #1	Value 50.00	Hz
SK #2	Value 60.00	Hz
SK #3	Value 400.00	Hz
SK #4	Value 800.00	Hz
SK #5	Value 1200.00	Hz



SK #	Value	Unit
SK #1	Value 0.00	Deg
SK #2	Value 90.00	Deg
SK #3	Value 120.00	Deg
SK #4	Value 180.00	Deg
SK #5	Value 240.00	Deg

6.7.8.3 Current Limit Soft keys



6.7.8.4 Power and VA Limit Soft keys



For each parameter, the user will be prompted to confirm soft key value setting changes. See dialog to the right. ►

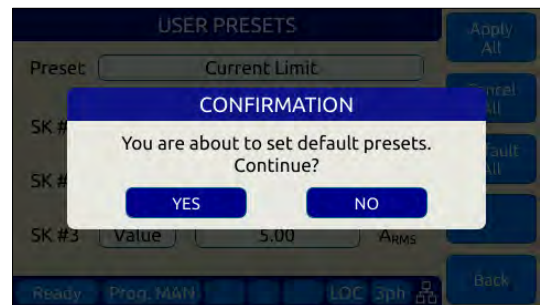

SOFT KEY	Description
Apply All (SK1)	Applies values entered by user.
Cancel All (SK2)	Cancel all changes made.
Default All (SK3)	Sets all soft key settings for selected parameter to factory defaults.
-	
Back (SK5)	Refreshes screen

6.8 SYST – SYSTEM Screens

The System screens allow setting of secondary system level functions that are used less often than the first four screens. This generally involves setting system level operation modes and parameters to tailor the instruments operation to the user’s specific requirements and operating environment. These include the following areas:

- Remote Control Interfaces
- System level settings, logs and firmware updates
- Calibration
- Parallel Operation
- Options if any

Pressing the **SYST** key will display the first of two CONFIGURATION screens as shown below.

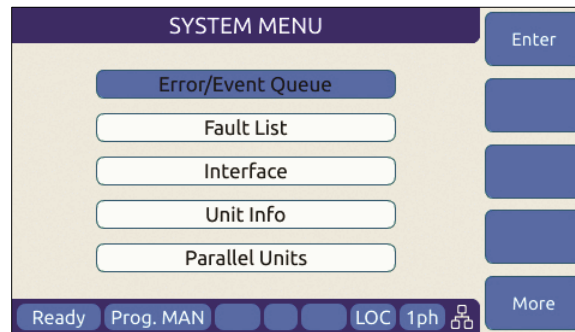

Figure 6-23: SYSTEM MAIN MENU 1

The **More** soft key will allow moving back and forth between the two main SYSTEM screens.

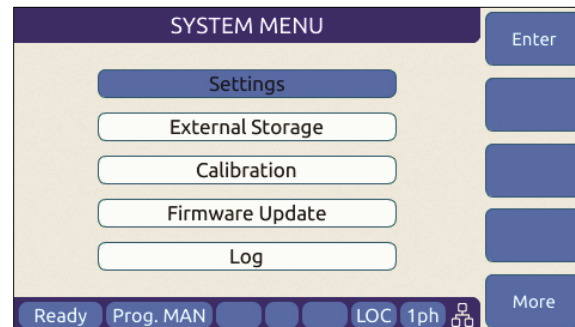

Figure 6-24: SYSTEM MAIN MENU 2

Selections on each screen are made by scrolling through the available entries using the shuttle knob. Pressing the **Enter** soft key, ENTER key or shuttle will display the selected highlighted entry screen.

6.8.1 SYSTEM MENU 1

The first SYSTEM MENU allows for selection of the following functions:

- Error/Event Queue Screen
- Fault Information Screen
- Interface Settings Screen
- Unit Information Screen
- Connected Units Screen
- SCPI Console

Each screen is covered in subsequent sections.



6.8.2 SYSTEM MENU 2

The second SYSTEM MENU allows for selection of the following functions:

- System Settings Screen
- Memory Management Screen
- Calibration Screen
- Firmware Update Screen
- Remote Support Screen

Each screen is covered in subsequent sections.



6.8.3 ERROR / EVENT QUEUE Screen

The Error and Event queue shows the history of any errors or events that have occurred since the last time the error queue was cleared.

The error queue can be cleared using a SCPI command over any of the remote control interfaces or by pressing the “Clear Queue” soft key while on this screen.

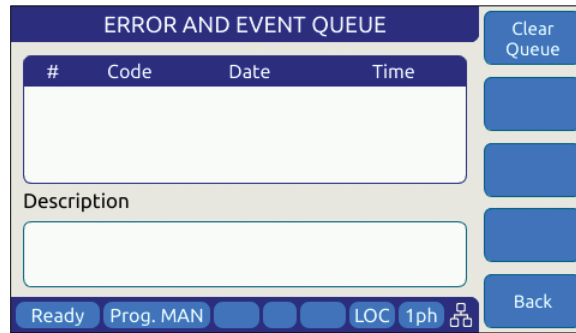

Figure 6-25: ERROR & EVENT QUEUE Screen

6.8.4 FAULT INFORMATION Screen

The fault list shows any logged internal operation faults. This information may be useful when trouble shooting any issues with the power source. In that even, customer service may request this information from the end user or request access to the instrument through the LAN interface for further diagnostics.

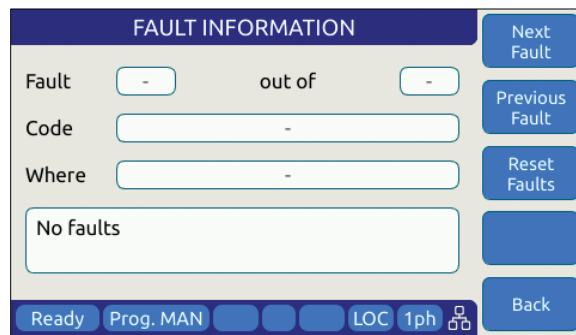

Figure 6-26: FAULT INFORMATION screen

6.8.5 INTERFACE Screen

The INTERFACE SETUP screen allows access to the setup parameter of any of the available remote control interfaces.

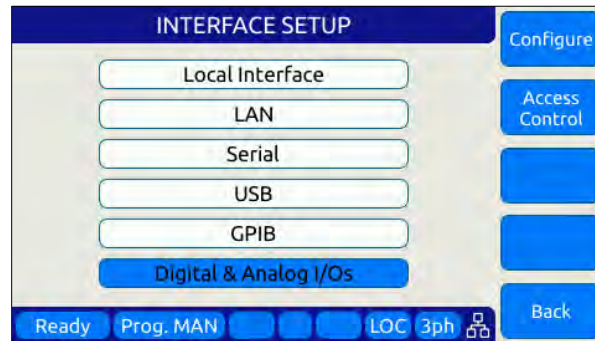

Figure 6-27: INTERFACE SETUP Screen

Available selections are:

- Local Interface (Relates to front panel operation)
- LAN – Ethernet Interface Setup
- Serial – RS232 Serial Interface Setup
- USB – USB Interface Setup
- GPIB – GPIB Interface Setup (Models with “G” option only)
- Digital & Analog I/O Setup

Each section is covered in subsequent sections.

6.8.5.1 LOCAL INTERFACE 1 OF 2

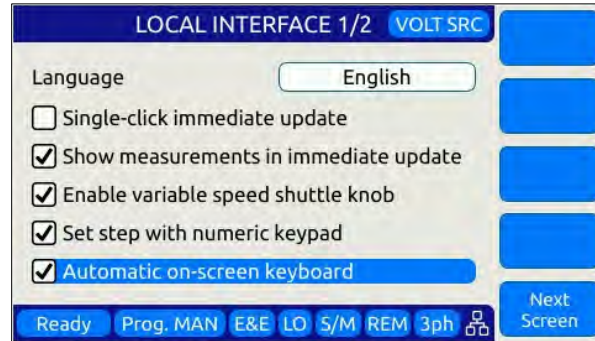

Several aspects of front panel operation can be configured by the user from this screen. This relates primarily to the language selection and operation of the shuttle knob, which has three distinct functions:

1. Scrolling values up or down
2. Single Click push function
3. Double Click push function

Parameters available to set are as follows:

Language

Available language selections are:

- English (default factory setting)
- Chinese.

Language can be switched by pressing the shuttle while on the language field and scrolling between available selections. Press ENTER to confirm selection.

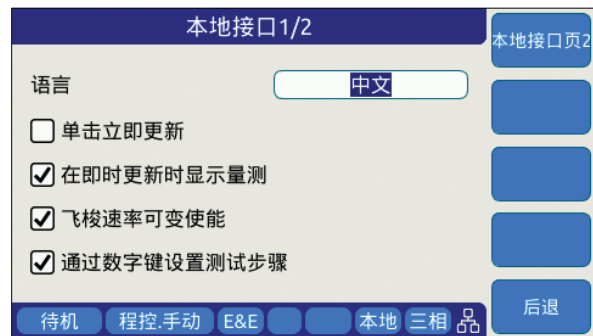

Single-Click Immediate Mode

Enters Immediate Mode upon single depression of shuttle knob. Immediate mode means value changes occur immediately on the output of the power source. When unchecked, a double click of the shuttle knob is required to enter this mode.

- Show Measurements in Immediate Mode** When checked, entering immediate mode will result in the Measurement screen being display with the changing parameter showing in the title bar. This allows monitoring of all output measurements while slewing voltage, current of frequency.

- Enable variable speed shuttle knob** When selected, the speed of rotating the shuttle knob will increase the step size of the parameter being changed. If unchecked, changes occur at a fixed step size (resolution).

- Set step with numeric keypad** When set, the numeric keypad can be used to increment or decrement the step size of the shuttle knob. Digits 9 to 1 our use to change from largest step size (9) to smallest step size (1) and any step size in between.

- Automatic on-screen keyboard** This selection enables the on-screen Qwerty keyboard pop-up when the scroll knob is pressed once. When turned OFF, it is still available but requires double clicking the knob. This touch keyboard allows entering of alpha numeric parameters and also supports number value entries. See next section for details.

The following soft keys are available from the LOCAL INTERFACE setup screen:

SOFT KEY	Description
Local Inter. Page 2. (SK1)	Toggle to LOCAL INTERFACE 2 OF 2 screen
-	
-	
-	
Back (SK5)	Returns to previous screen

Table 6-28: Available USER INTERFACE screen soft keys

6.8.5.2 TOUCHSCREEN KEYBOARD

The on-screen Touchscreen Keyboard features allow entry of alpha numeric values such as names in text entry fields from the front panel. It pops up when the scroll knob is pressed once is set to on or double clicked when set to off in the LOCAL INTERFACE 1 OF 2 Screen.

It is mainly intended for use in text entry fields as the numeric keypad is always available for numeric entries. These are several keyboards available and the default type depends on the data entry field the cursor is on when the shuttle knob is pressed. The number of text characters in each keyboard is limited by the field type.

Key Descriptions

The following keys are supported:



1. Shift: Allows switching between lowercase and uppercase letters, numbers and symbols.
2. 123/ABC: Allows switching from letters to numbers and symbols or vice versa.
3. Return: Places the cursor at the end of the text.
4. Backspace: Deletes the previous character depending on the cursor position
5. Apply: Closes the keyboard and apply text to the field.
6. Clear: Clears all text.
7. Arrows: Allows moving through the text.
8. Cancel: Discards text and close the keyboard

Available Qwerty keyboard Types:

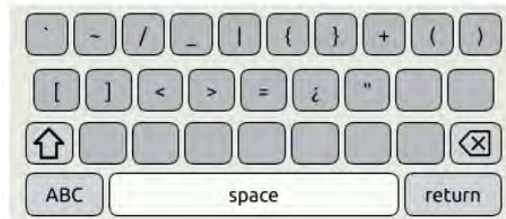
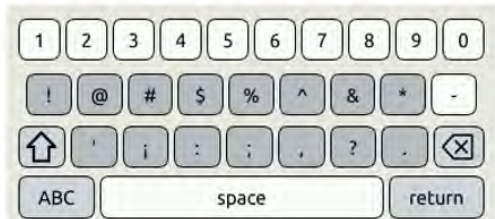
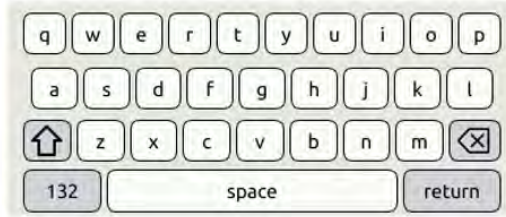
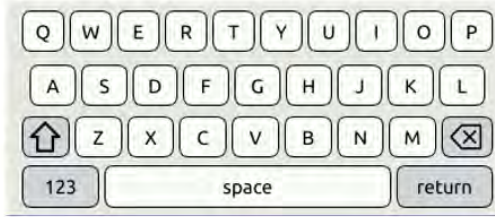

Web Browser Front Panel Mode.

The same on-screen keyboard functions are available from the Web browser interface via LAN or USB as shown below.



6.8.5.3 LOCAL INTERFACE 2 OF 2

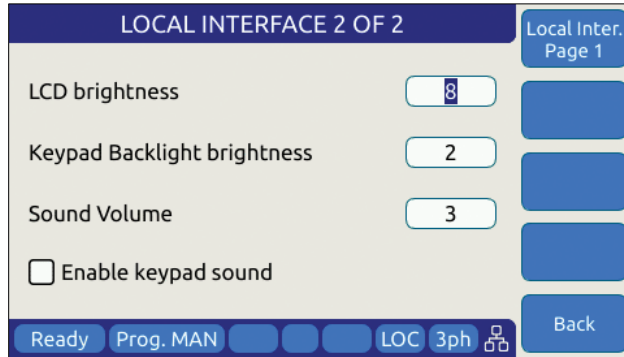

Several aspects of front panel operation can be configured by the user from this screen. These settings relate primarily to visual and audible user interface aspects:

1. LCD brightness
2. Keyboard Backlight
3. Sound Levels

Parameters available to set are as follows:

LCD brightness	Adjusts the LCD display backlight brightness. Range is 0-9.
Keypad Backlight brightness	Adjusts the keyboard backlight brightness. Range is 0-9.
Sound Volume	Adjusts the loudness of the keyboard and message beeps.
Enable keypad sound	Enables or Disables audible beeps when operating the keyboard.

The following soft keys are available from the LOCAL INTERFACE setup screen:

SOFT KEY	Description
Local Inter. Page 1. (SK1)	Toggle to LOCAL INTERFACE 1 OF 2 screen
-	
-	
-	
Back (SK5)	Returns to previous screen

Table 6-29: Available USER INTERFACE screen soft keys

6.8.5.4 LAN (ETHERNET) INTERFACE SETUP Screen

The LAN INTERFACE SETUP screen allows configuring the Ethernet interface for use with your local area network (LAN) and is accessed from the INTERFACE SETUP screen.

CAUTION

Do NOT connect the RJ45 LAN (Ethernet) connector of the power source to a PoE (Power over Ethernet) port as the DC voltage will damage the LAN interface.

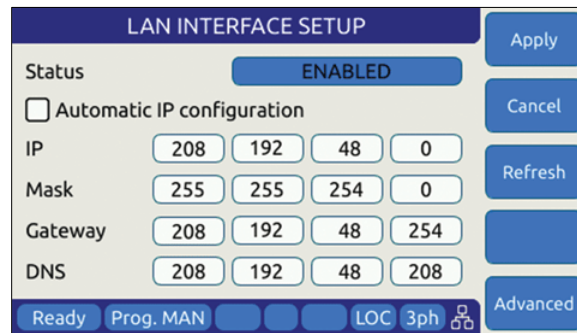

Figure 6-28: ETHERNET INTERFACE SETUP Screen

This screen is used to configure the Ethernet interface for your local area network.

Note: You may need to consult your network administrator to set up this interface correctly.

The following parameters can be set on this screen:

- Automatic IP Configuration** Select this mode if your network has a domain name server running. An IP address will be assigned by the DNS each time the power source is turned on.
- IP** IP address setting. This address must be unique to your network segment. Consult your network administrator if you are not sure about this setting.
- Mask** IP mask setting. This mask must be correct for your network. Consult your network administrator if you are not sure about this setting.
- Gateway** Gateway address setting. Consult your network administrator if you are not sure about this setting.
- DNS** Domain Name Server address setting. Consult your network administrator if you are not sure about this setting.
- Port** Port socket address. For message based instruments like this power source, this setting is typically 5025.

The following soft keys are available from the ETHERNET INTERFACE SETUP screen:

SOFT KEY	Description
Apply (SK1)	Accepts new settings and returns to previous screen.
Cancel (SK2)	Returns to the previous screen.
Refresh (SK3)	
-	
Advanced (SK5)	Access detailed LAN Interface Setting screen

Table 6-30: Available ETHERNET INTERFACE SETUP screen soft keys

6.8.5.5 SERIAL INTERFACE SETUP Screen

The SERIAL INTERFACE SETUP screen allows configuring the RS232 serial interface and is accessed from the “INTERFACE SETUP” screen.

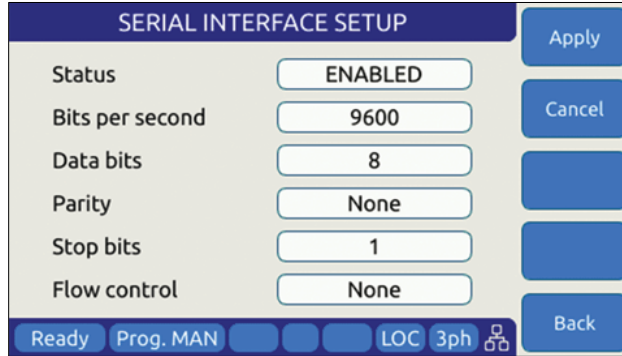

Figure 6-29: SERIAL INTERFCE SETUP Screen

The following parameters can be set on this screen:

- Bits per second** Sets the baud rate. Available settings are 9600, 14400, 19200, 38400, 57600 or 115200.
- Data bits** Sets the number of bits per frame. Available settings are 7 or 8 bits
- Parity** Sets parity check to either odd, even or none.
- Stop bits** Sets the number of stop bits as either 1 or 2.
- Flow control** Sets handshake mode to None or Xon/Xoff

The following soft keys are available from the SERIAL INTERFACE SETUP screen:

SOFT KEY	Description
Apply (SK1)	Accepts new settings and returns to previous screen.
Cancel (SK2)	Returns to the previous screen.
-	
-	
Back (SK5)	Returns to the previous screen.

Table 6-31: Available SERIAL INTERFACE SETUP screen soft keys

6.8.5.6 USB INTERFACE SETUP Screen

The USB INTERFACE SETUP screen allows configuring the USB interface and is accessed from the INTERFACE SETUP screen.

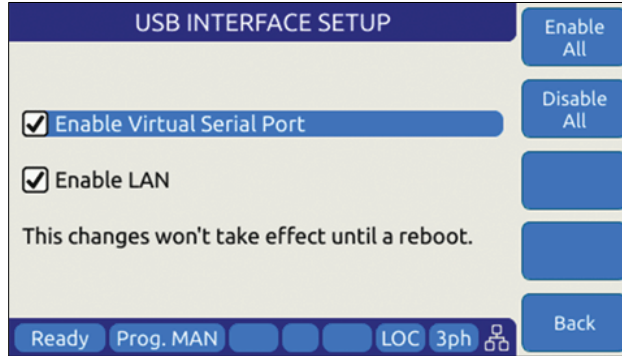

Figure 6-30: USB INTERFACE SETUP Screen

The following settings can be configured on this screen:

- Enable Virtual Serial Port** Enables or disables PC control using a virtual serial port driver.
- Enable LAN** Enables or disables the LAN (Ethernet) Interface IP emulation mode, which supports use of the embedded LXI web server. The virtual IP address of the USB-LAN emulation mode is fixed at 192.168.123.1.

Note: Any changes made to this screen will NOT take effect until the power source has been completely powered off and back on. (Re-boot).

The following soft keys are available from the USB INTERFACE SETUP screen:

SOFT KEY	Description
Enable All (SK1)	Set all check boxes
Disable All (SK2)	Clear all check boxes
-	
-	
Back (SK5)	Returns to the previous screen.

Table 6-32: Available USB INTERFACE SETUP screen soft keys

6.8.5.7 GPIB INTERFACE SETUP Screen

The GPIB INTERFACE SETUP screen allows configuring the GPIB interface and is accessed from the INTERFACE SETUP screen.

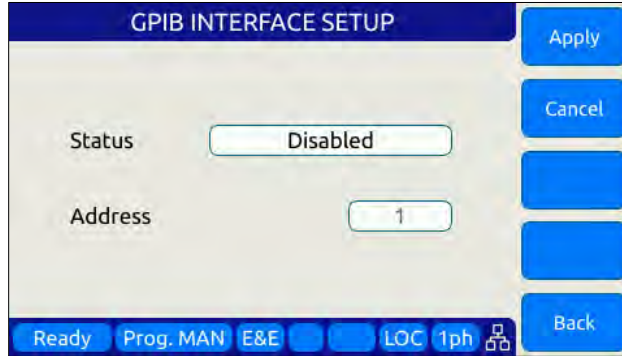

Figure 6-31: USB INTERFACE SETUP Screen

The following settings can be configured on this screen:

- Status** Enables or disables the GPIB interface. Disable when not in use to avoid erroneous interrupts.
- Address** Sets GPIB bus address. Available range is from 1 through 30. Default factory setting is address 1.

The following soft keys are available from the GPIB INTERFACE SETUP screen:

SOFT KEY	Description
Apply (SK1)	Accepts new settings and returns to previous screen.
Cancel (SK2)	Returns to the previous screen.
-	
-	
Back (SK5)	Returns to the previous screen.

Table 6-33: Available GPIB INTERFACE SETUP screen soft keys

6.8.5.8 DIGITAL & ANALOG I/Os SETUP Screen

The Digital & Analog IOs SETUP screen allows configuring the auxiliary I/O interfaces and is accessed from the INTERFACE SETUP screen.

For further details, refer to Section 7.3, “Auxiliary I/O” on page 203.

6.8.5.9 REMOTE INHIBIT SETUP Screen

The REMOTE INHIBIT SETUP screen allows configuring the remote output control input for various modes of operation. Once set, this setting is retained in non-volatile memory so the selection persists between input power cycles.

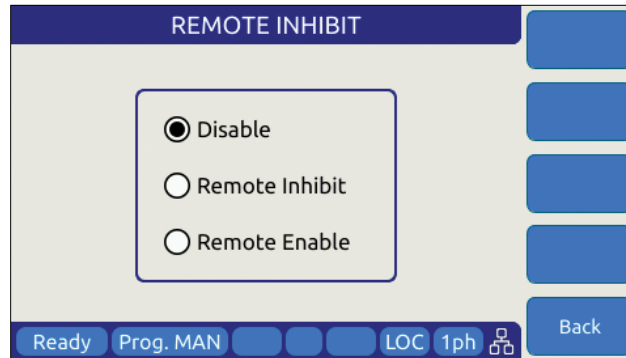

Figure 6-32: REMOTE INHIBIT Setup Screen

There are three modes of operation for this input: remote inhibit and remote enable.

1. **Disable mode:** In this mode, the Remote Inhibit inputs are not active so this function is turned off. No short between the RI pins is required to enable the output in this mode.
2. **Remote Inhibit mode:** The two pins have to be shorted for the output to be enabled from the front panel or remote command. This is a necessary but not a sufficient condition to enable the output. If the output is enabled and the remote inhibit connection is open, a fault is generated. This mode is recommended for interlock safety applications such as safety cages and test fixture interlocks.
3. **Remote Enable mode:** The output can be enabled by shorting these two pins, regardless of the output enable command/button. It is a sufficient condition to enable the output.

RS232 Interface and Remote Inhibit Function

On AFX Series models with firmware revision numbers lower than 2.0.13, there is a conflict between the RS232 interface and the Remote Inhibit function. Both cannot be used at the same time. To enable the Remote Inhibit input control line, the RS232 interface must be disabled. This can be done using the browser interface over LAN or USB or from the front panel. If the Remote Inhibit function is needed, use the USB interface instead of RS232.

To disable RS232 from Web browser, select **SYSTEM** Menu -> **INTERFACE SETUP** and move the SERIAL CONFIGURATION ENABLE position to OFF.

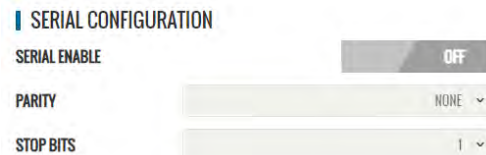

To disable RS232 from the front panel, press the CONFIGURATION key to the left of the LCD, select Interfaces, then select RS232 Interface and set the Status field to **Disabled**. Refer to section 6.8.5.4 on page 182.

Note: For units with firmware revision 2.0.13 or higher, the RS232 interface is automatically disabled when enabling Remote Inhibit.

6.8.5.10 REMOTE SHARING

Remote sharing of the power source is provided using one of two protocols:

Samba: Samba is a free software re-implementation of the SMB networking protocol. Server Message Block (SMB), also known as Common Internet File System (CIFS) operates as an application-layer network protocol for providing shared access to resources miscellaneous communications between nodes on a network.

FTP: File Transfer Protocol. FTP is built on a client-server model architecture using separate control and data connections between the client and the server.

Note: Either one or both may be chosen. It is strongly recommended to set a custom password to prevent unauthorized access to the power source.

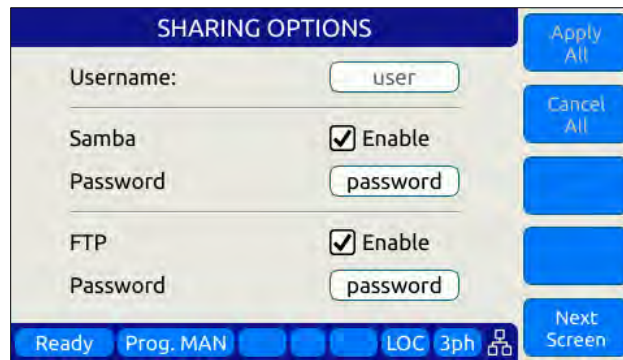

SHARING OPTIONS	
Username:	user
Samba	<input checked="" type="checkbox"/> Enable
Password	password
FTP	<input checked="" type="checkbox"/> Enable
Password	password

Ready Prog. MAN LOC 3ph

6.8.6 UNIT INFORMATION Screen

The UNIT INFORMATION screen is an information only screen that contains information about the power source and is accessed from the SYSTEM SETTINGS screen using the “Unit info” soft key (SK3).

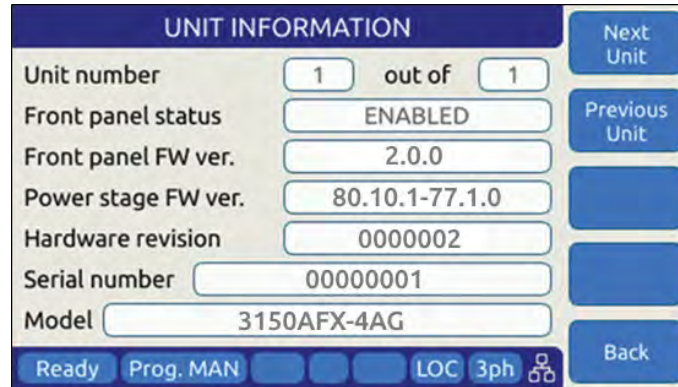

Figure 6-33: UNIT INFORMATION Screen

The following information is provided on this screen:

- Unit Number** Shows the position of this unit in a string of paralleled power sources. For a stand-alone power source, the display will show 1 of 1.
- Front panel status** Shows the status of the front panel. Only the MASTER unit in a multi-unit system will have its front panel enabled.
- Front panel FW ver.** Firmware revision of the front panel control processor.
- Power stage FW ver.** Firmware revision of the power stage processors.
- Hardware revision** Hardware build revision.
- Serial number** Unit Serial number.
- Model** Model number, typically 3xxxAFX where xxx = power rating.

Note: This information is for information purposes only and cannot be changed by the operator.

The following soft keys are available from the UNIT INFORMATION screen:

SOFT KEY	Description
Next Unit (SK1)	If this unit is part of a parallel system, information on the next unit in the chain will be displayed.
Previous Unit (SK2)	If this unit is part of a parallel system, information on the previous unit in the chain will be displayed.
-	
-	
Back (SK5)	Returns to the previous screen.

Table 6-34: Available UNIT INFORMATION screen soft keys

6.8.7 CONNECTED UNITS Screen

The CONNECTED UNITS screen controls the behavior of this power source in a multi-unit parallel or series system where two or more power sources are either paralleled or in series (AFX models) to provide higher power level systems.

This screen is accessed from the SYSTEM SETTINGS screen using the “Connected Units” entry.

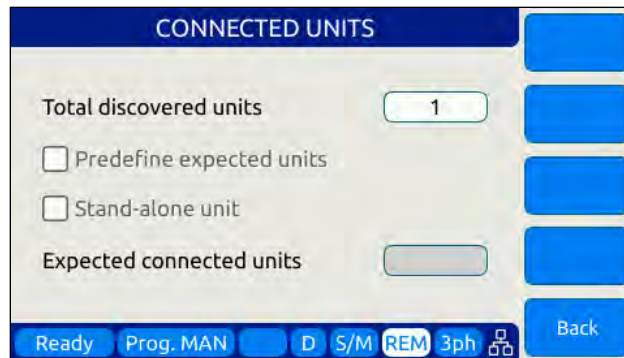

Figure 6-34: CONNECTED UNITS Screen

The first field shows the number of units found at power up on the system bus. A value of 1 means this is a stand-alone unit (not part of a larger system).

The following settings can be configured on this screen:

- Predefine expected units** Tells the power source how many total units to expect to find on the system interface bus at power up. If the number found is less than the number expected as set by the user, one or more units may not be powered up or missing. Leaving this check box off means the system will operate with the number of units found, regardless.
- Stand-alone unit** Set this check box if you want the power supply to operate as a stand-alone unit, even if it is connected to the system interface bus. To do so, you must make sure the outputs of this power source are not connected to any other units’ outputs.
- Expected parallel units** Use this field to enter the number of expected units only if the “Predefine expected units” option is checked.

The following soft keys are available from the PARALLEL UNITS screen:

SOFT KEY	Description
Discover units (SK1)	Re-scan the system interface bus to determine how many units are on the bus. This also happens at power on.
Back (SK5)	Returns to the previous screen.

Table 6-35: Available PARALLEL UNITS screen soft keys

6.8.8 SCPI CONSOLE

The SCIP Console screen allows entry of remote control SPCI command directly from the front panel instead of one of the available remote-control interfaces. This feature is similar to the command line available at the bottom of the Web browser interface Home page.



The following softkeys are available to operate this feature:

Query / Write	Sends the SCPI command shown in the command line on top. The default command is the *IDN? Query which returns the make and mode of the power source. This field will also retain the last command entered by the user.
Clear	Clears the test in the command line and the response area below it.
Scroll Up/Down	Allows scrolling of the text in the response area.
Back	Returns to the System Menu page.

6.8.9 SYSTEM SETTINGS Screen

This screen allows system level settings such date and time to be changed. It also access to the UPC Compatibility mode setting.

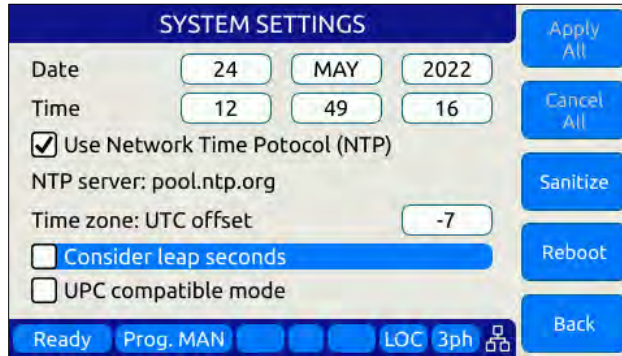

Figure 6-35: SYSTEM SETTINGS Screen

The following parameters can be set from this screen:

- Date** Sets the date for the real-time clock.
- Time** Sets the time for the real-time clock.
- Use Network Time Protocol** When set, the time and date will be adjusted based on the NTP protocol. This requires the unit to be connected to a local area network.
- Time zone UTC offset** This parameter sets the number of time zone from UTC where the unit is located to reflect local time. Coordinated Universal Time (UTC) is the primary time standard by which the world regulates clocks and time. It does not observe daylight saving time.
- Consider Leap Seconds** When enabled, the time setting incorporated any lead seconds for the current year in the time setting.
- UPC compatible mode** When enabled, the controller operates in UPC compatibility mode for back ward compatibility with legacy PPS UPC controllers

The soft keys on the SYSTEM SETTINGS screen provide access to additional functionality as listed in the table below.

SOFT KEY	Description
Apply All (SK1)	Applies all changes made to this screen.
Cancel All (SK2)	Cancels any changes made and returns to previous screen
Sanitize	Erases all user settings from the unit and returns it to its factory default state.
Reboot	Reboot front panel controller without cycling AC input power.
Back (SK5)	Returns to the previous screen.

Table 6-36: Available SYSTEM SETTINGS screen soft keys

6.8.10 MEMORY MANAGEMENT Screen

The AFX Series® is able to use a wide variety of external storage devices such as USB memory sticks and SD-Cards in addition to its internal storage memory. These devices may be used to store or load data, programs (setup + transient) etc.

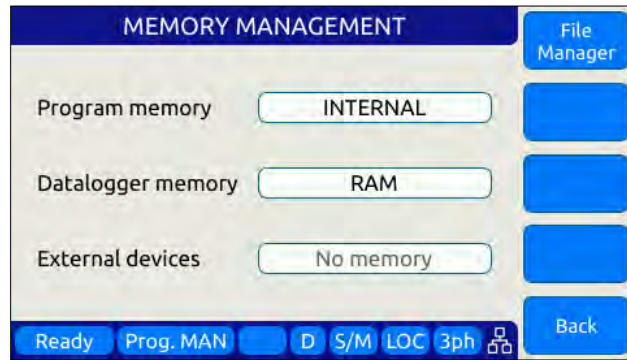

Figure 6-36: MEMORY MANAGEMENT Screen

Program storage memory defaults to INTERNAL but can be changed to any available (inserted and mounted) external memory device if needed. The first parameter field is used to make this selection.

If any external memory devices are inserted, they will appear in the “External memories” field at the bottom of this screen.

Note: Maximum supported external memory device storage size is 32 GBytes.

The following files types can be located in each of these directories.

Subdirectory	File type and naming convention
plot	Measurement plots
sequences	Test sequences
screenshots	PNG image files captured from the LCD screen with filename convention screenshot_YYYY-MM-DD_HH-MM-SS.png where YYYY-MM-DD_HH-MM-SS is the time stamp.
waveforms	CSV comma separated waveform data files with filename convention X.csv where X is a number from 2 through 200.
program	Steady state + transient segment files using filename convention program_xx.xml where xx = 00 through 99 indicated program memory location #.

6.8.10.1 Loading Programs from a USB Drive.

Programs stored on a USB drive using the directory structure shown in the previous section can be loaded using the Browser interface – see section 10.7.4 on page 449– or from the front panel.

To load from the front panel USB ports, store the program_xx.xml file in the program subdirectory and insert in one of the two USB A ports on the front panel. After a short period of time, the drive will mount and will be visible in the CONF -> PROGRAM BROWSER screen.



Select the USBA1 drive in the upper right corner Memory field to see the available program files on the USB drive. Scroll down with the shuttle to select the desired program file to load.

Then use the **Recall** Softkey to load the selected program file. The program will now be available in the assigned program memory location as determined by the XML file name.



Note: program_xx.xml files must have a Steady State section to be valid. The Transient section may be empty in which case no transient will be loaded.

6.8.10.2 File Manger Operation

To access the File Manager functions, Press “**SYST**” -> **Memory management**” –(**Sk1**) **File Manager**”. The File Manager allows the user to browse through the directories and files stored on the selected memory type, INTERNAL, RAM or External media. Select the relevant memory type before entering this screen. See sample screens below.

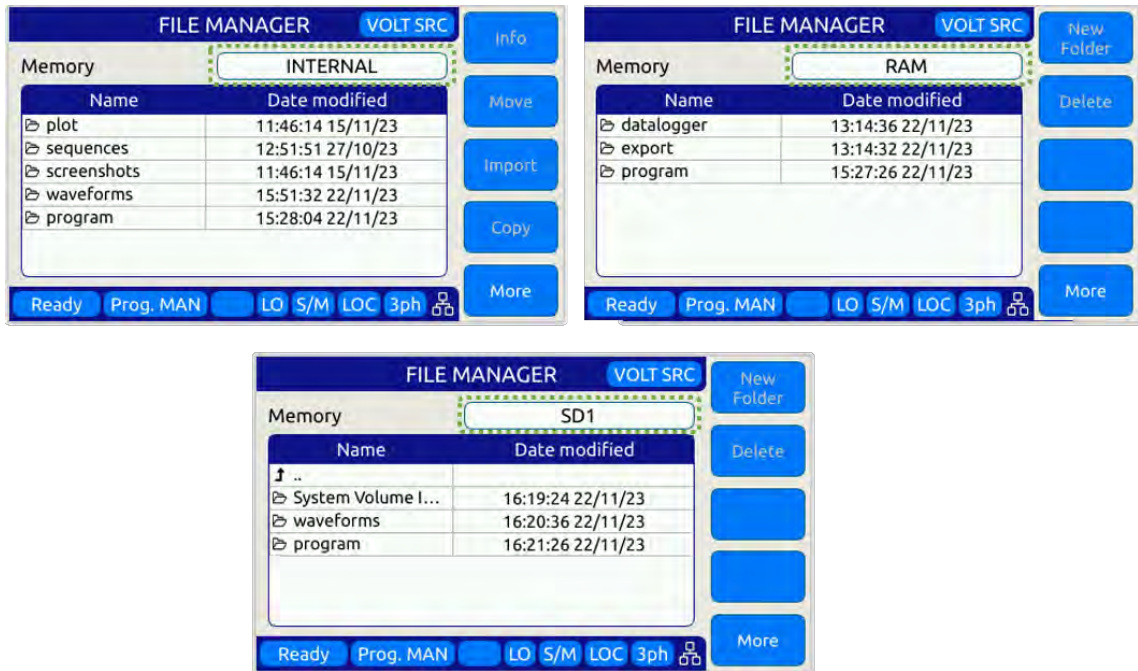

This screen contains file info such as date/time, and supports the following functions:

1. Move, Copy and Delete files.
2. Create new folders.
3. Import Waveforms.
4. Import Programs.

To navigate between files and folders, use the shuttle knob to select a folder and press to enter.

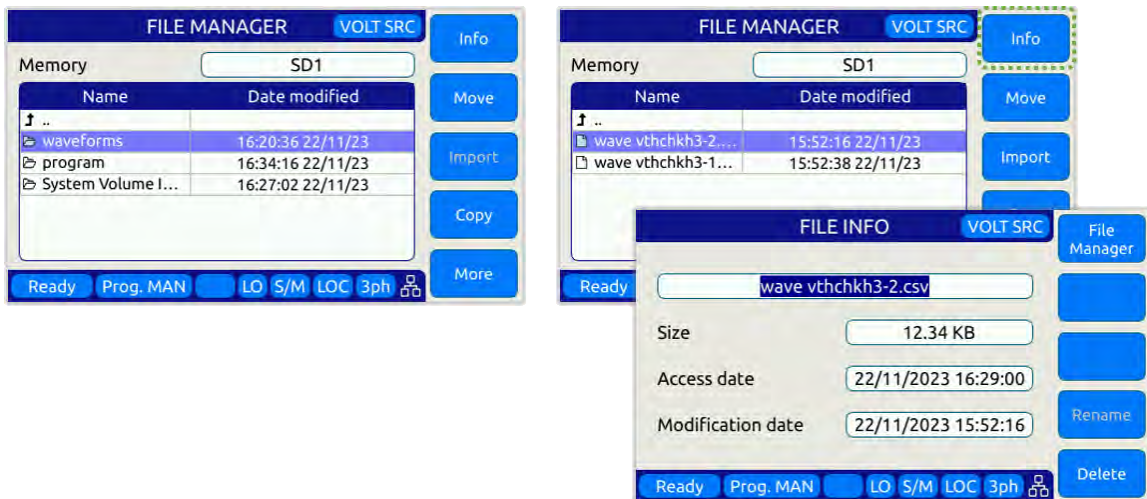

Importing Waveforms

The Import softkey allows importing of CSV format waveforms. Select the location to import the content of the waveform from. Use the +/- softkeys or the shuttle knob to scroll the waveform number. Press the Import (Sk1) softkey and YES to confirm when prompted.

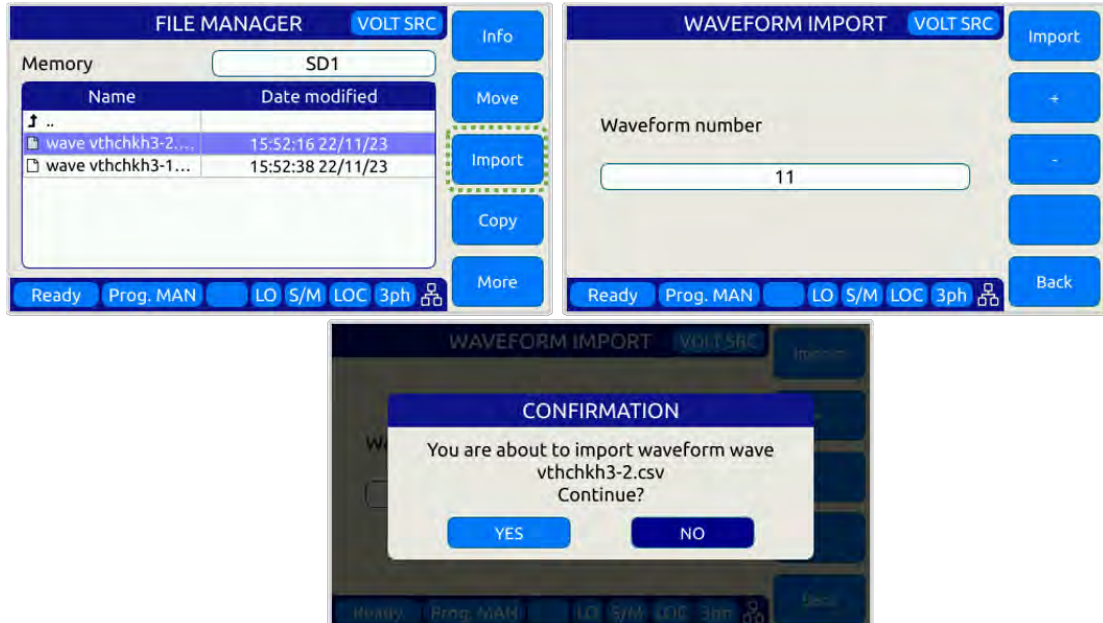

Importing Programs

Importing xml format program files uses a similar process except they are stored in a register location by number. Select the desired program file, select the memory type and register number and press Import (Sk1), the confirm when prompted.

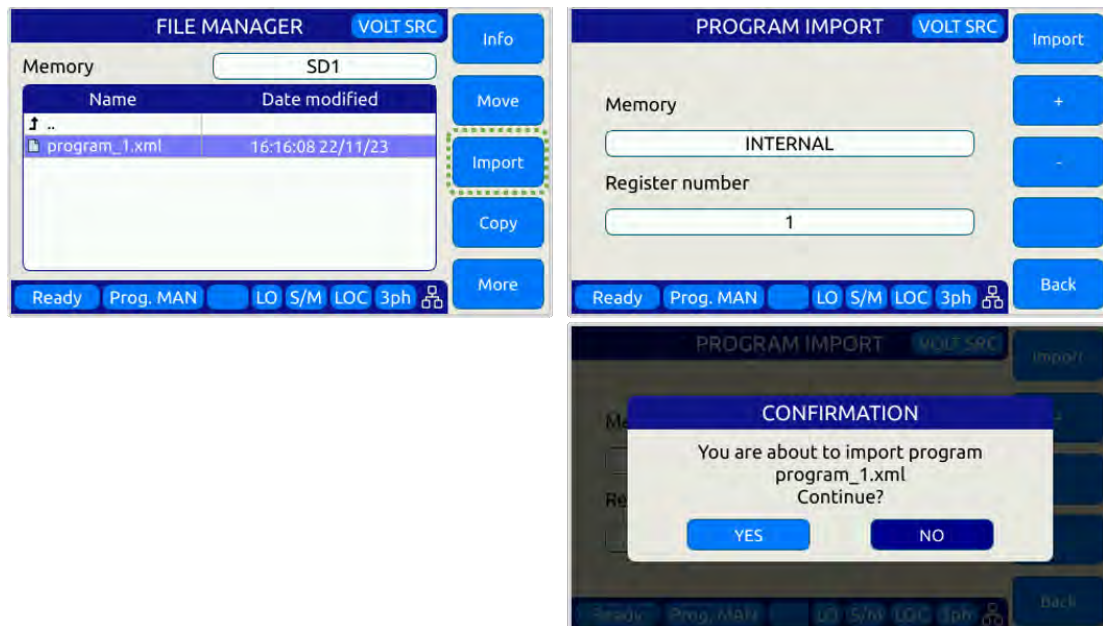

Moving Files

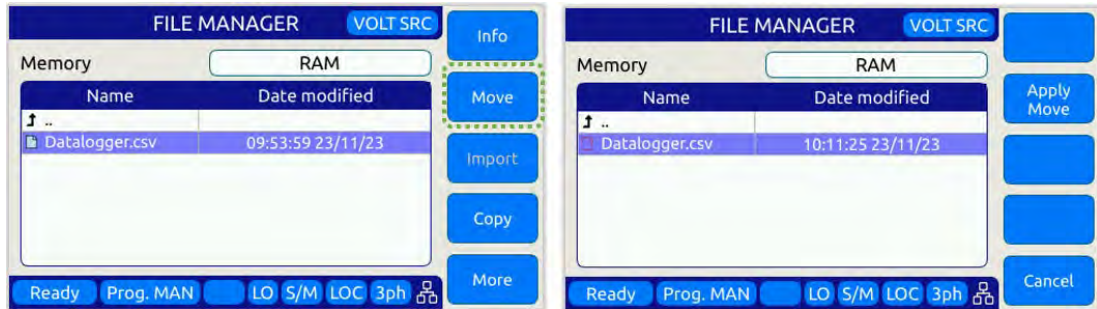

- Changes the directory and then press “Apply Move”

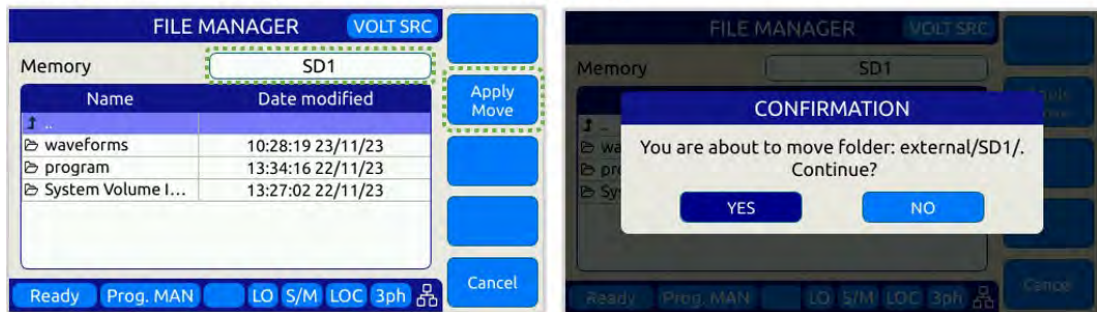

Copy and Pasting Files

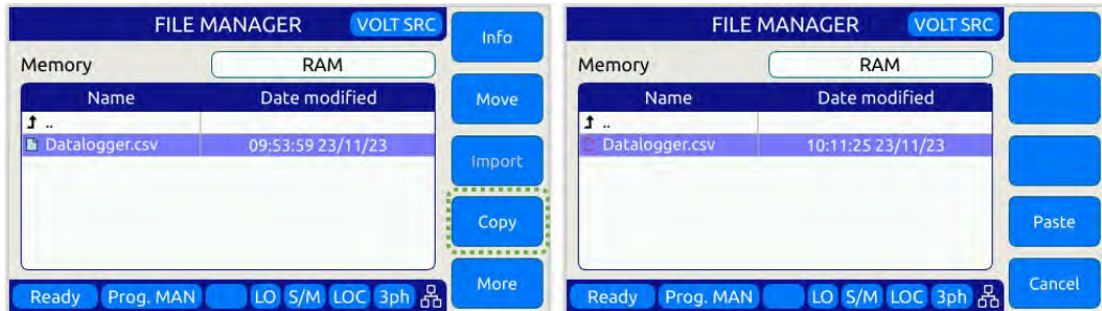

Changes the directory (and/or Memory) and then press “Paste”

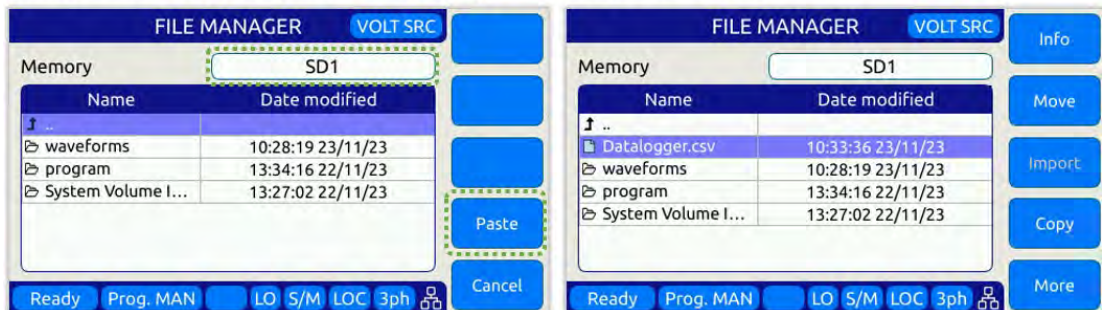

Deleting Files

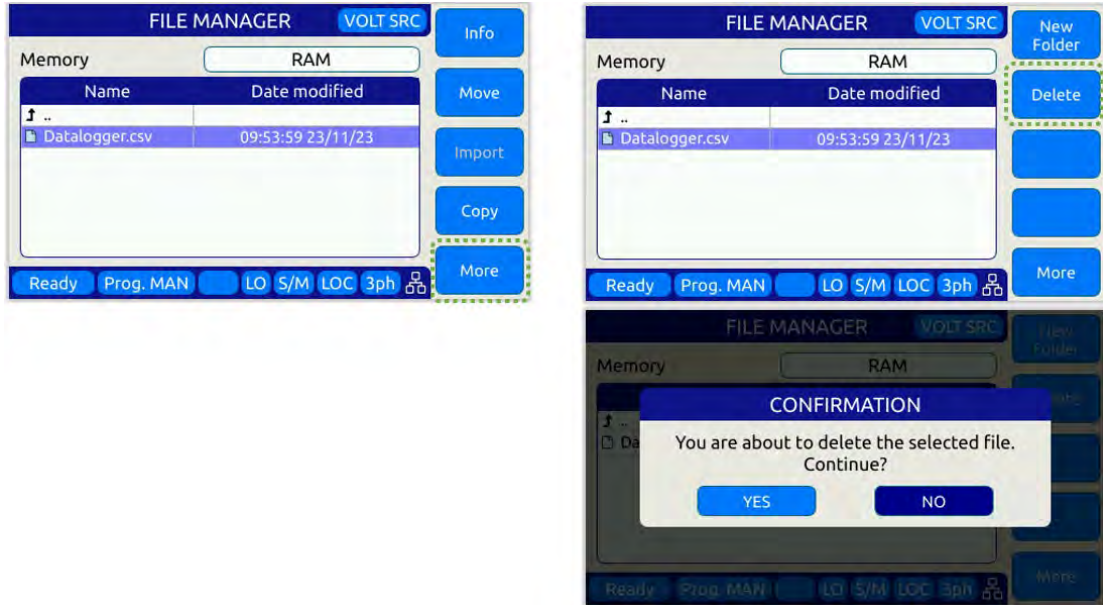

6.8.11 CALIBRATION MENU Screen

All power sources are shipped with a Certificate of Compliance to NIST traceable standards (“CoC”) from the factory. Output and Measurements are calibrated to an external reference DMM at the same time. A suitable current shunt or current transformer and a load will be required to perform calibration.

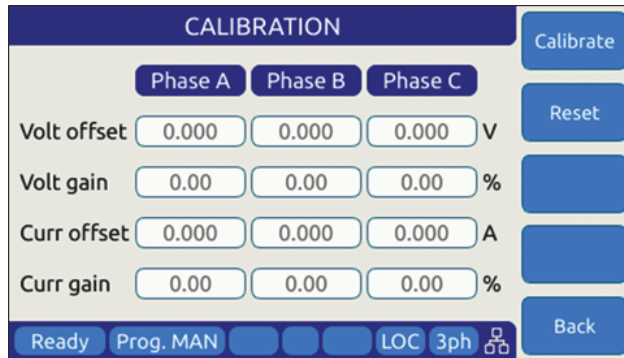

Figure 6-37: CALIBRATION MENU Screen

The following soft keys are available from the CALIBRATION MENU:

SOFT KEY	Description
Calibrate (SK1)	Enters calibration state
Reset (SK2)	Resets all calibration coefficients' previous values.
-	
-	

SOFT KEY	Description
Back (SK5)	Returns to previous screen

Table 6-37: Available CALIBRATION MENU screen soft keys

For details on calibration requirements and procedures, refer to the Calibration section towards the end of this manual. (Section 11, “Calibration”).

6.8.12 FIRMWARE UPDATE Screen

Firmware updates may be distributed via different media such as SD-Card, USB memory stick or on-line through Pacific’s FTP site. The FIRMWARE UPDATE screen provides the means for the end user to perform a firmware update.

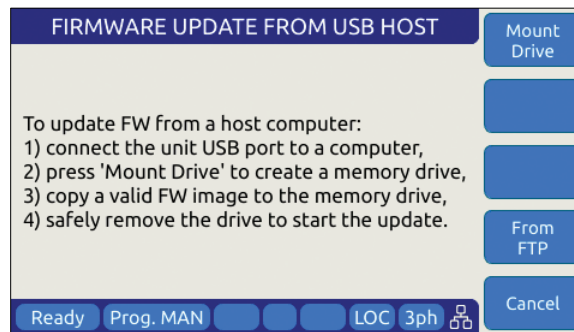

Figure 6-38: FIRMWARE UPDATE Screen

The following soft keys are available from the FIRMWARE UPDATE screen:

SOFT KEY	Description
Mount Drive (SK1)	Mount media that contains new firmware revision.
-	-
From FTP (SK4)	Install latest firmware from Pacific Power Sources’ FTP server.
Cancel (SK5)	Exit firmware update screen

Table 6-38: Available FIRMWARE UPDATE screen soft keys

6.8.13 REMOTE SUPPORT Screen

The REMOTE SUPPORT feature can be used to send information to customer support in case the user experiences an issue with the unit. It also provides a means to allow Pacific’s technical support team to access the unit remotely assuming it is connected to a network with Internet access.

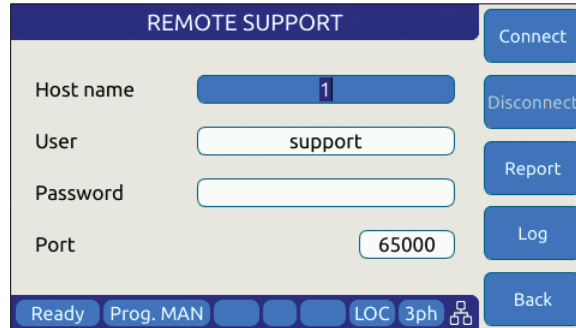

Figure 6-39: REMOTE SUPPORT Screen

The Report soft keys will cause a detailed report to be generated and sent to Pacific Power Source customer support so we can assist in resolving any technical support issues.

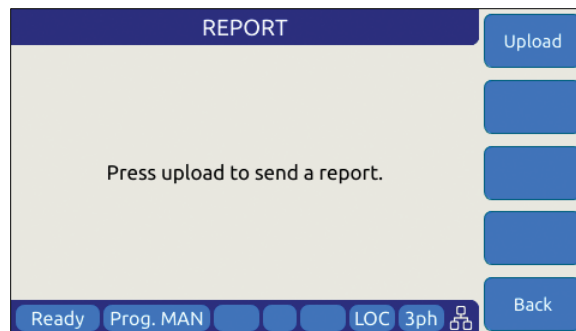

Figure 6-40: Remote Support REPORT Screen

The following soft keys are available from the LOGGING TOOL screen:

SOFT KEY	Description
Connect (SK1)	Connect to Pacific Power Support site
Disconnect (SK2)	Disconnect from Pacific Power Support site
Report (SK3)	Generates a report for Customer Support Department
Log (SK4)	Start Logging
Back (SK5)	Returns to the previous screen.

Table 6-39: Available LOGGING TOOL screen soft keys

7 Rear Panel, Connectors and Protection

This section describes the rear panel layout of the AFX Series® AC power source.

7.1 OUTPUT Terminals



CAUTION

HAZARDOUS OUTPUT: The power source output may be set to hazardous voltage levels. It provides basic isolation from the AC input mains. Therefore, the output must always be considered hazardous. Connections must be inaccessible to the operator in all situations when AC input mains voltage is applied.

Always disconnect power supply from the mains before connecting or disconnecting to the hazardous output terminals.



AVERTISSEMENT

SORTIE DANGEREUSE: La sortie de l'appareil peut être réglée à des niveaux de tension dangereux. L'appareil fournit une isolation de base du réseau d'entrée AC. Par conséquent, la sortie doit toujours être considérée comme dangereuse. Les connexions doivent être inaccessibles à l'opérateur dans toutes les situations où la tension d'entrée secteur est appliquée.

Toujours débrancher l'alimentation secteur avant de connecter ou déconnecter les bornes de sortie dangereuses.

The output terminal block for load connections is located near the center of the rear panel.

Note: Always refer to Section 2.3 “Safety Information” and Section 5.14, “Load Connections” on page 67 before making any load connections.

7.1.1 Output Power Connector Rating and Isolation

Maximum rated output voltage:	300V rms AC, 425Vdc
Maximum Current Rating:	60A
Connector Type:	Phoenix Contact SPC 16/ 6-STF-10, 16 - 1711417
Designated Use:	AC or DC Load Connection
Isolation Rating:	600V
Wire Stripping Length:	18 mm
Nominal Contact Cross Section	16 mm ²

7.1.2 Wire Size

A major consideration in making load connections is the wire size. The minimum wire size is required to prevent overheating and to maintain good regulation. It is recommended that the wires are sized large enough to limit the voltage drop at the maximum current rating of the AC power source to less than 0.5V per lead.

Wire size also depends on ambient temperature and total wires in the cable bundle. For example, for the full 41.7 amp current capability of a single output, at an ambient temperature of 30 °C, in a bundle of not more than three 75 °C rated wires, common electrical codes would recommend AWG 8 size (~10 mm²). However, maximum supported Wire Size for the output connector is AWG 6.

AWG	Diameter		Turns of wire, without insulation		Area	
	(in)	(mm)	(per in)	(per cm)	(kcmil)	(mm ²)
6	0.1620	4.115	6.17	2.43	26.3	13.3

7.1.3 Connecting a UUT

When setting up for a new test and connecting any equipment to the AC power source, proceed as follows:

1. Always make sure the AC power source is turned OFF at the POWER switch when making any wire connections.
2. Check that the output of the equipment under test is **OFF**.
Note: Some power equipment's output may still be energized even if the equipment has been turned off or its output is turned off. This is especially true for AC power sources.

Note: When working with batteries, it is recommended to provide a suitable

disconnect relay or switch so the AC power source can be physically disconnected from the battery for handling purposes.

3. Connect one end of the load wires to the output terminals on the rear panel.
4. Check the polarity of the connections and connect the other end of the load wires to the input terminals of the equipment under test.

7.2 External Voltage Sense Input Terminals



CAUTION

HAZARDOUS OUTPUT: The power source output may be set to hazardous voltage levels. It provides basic isolation from the ac input mains. Therefore, the external voltage sense must also always be considered hazardous. Connections must be inaccessible to operator in all situations when ac input mains voltage is applied.

Always disconnect power supply from the mains before connecting or disconnecting to the hazardous external voltage sense terminals.



AVERTISSEMENT

SORTIE DANGEREUSE: La sortie de l'appareil peut être réglée à des niveaux de tension dangereux. L'appareil fournit une isolation de base du réseau d'entrée AC. Par conséquent, la sortie doit toujours être considérée comme dangereuse. Les connexions doivent être inaccessibles à l'opérateur dans toutes les situations où la tension d'entrée secteur est appliquée.

Toujours débrancher l'alimentation secteur avant de connecter ou déconnecter les bornes de sortie dangereuses.

This section covers external voltage sensing. This feature improves voltage accuracy at the point of load when used correctly.

Note: External Voltage sense is sometimes referred to as Remote Voltage sense and Internal Voltage sense is sometimes referred to as Local Voltage sense. Both definitions are used in the industry. For consistency, External Voltage Sense and Internal Voltage Sense are used in this manual.

7.2.1 External Voltage Sense Connector Rating and Isolation

Maximum rated voltage:	400V rms AC, 425Vdc
Maximum Current Rating:	1A
Connector Type:	AFX L Version: Phoenix Contact P/N DFK-MSTBA 2,5 / 6-GF-5,08 – 1899029. Mating connector provided in ship kit is P/N FKC 2,5 / 6-STF-5,08 - 1873249 AFX A Version: Phoenix Contact P/N SPT 5 / 6-H-7,5-ZB - 1719231
Designated Use:	AC or DC Load Connection
Isolation Rating:	600V
Wire Stripping Length:	10 mm

7.2.2 Load Connection without External Voltage Sense

AFX Series® power sources can be operated with internal voltage sense. For higher current loads, the voltage at the load will drop due to the load cable impedance. Using the proper wire gauge for the rated current of the AC source is required to minimize load cable impedance.

7.2.3 Load Connection with External Voltage Sense.

The following points must be considered, when existing sense cables are connected directly to the load or to the central load distribution point:

1. Minimize the distance between the AC power source and the load as much as possible to keep load wire length to a minimum.
2. Directly connect **A, B, C** and **N** with **correct phasing** to the load distribution point
3. Twist each phase sense wire with a neutral sense wire to minimize cross talk. Three neutral connection points are provided for this purpose.

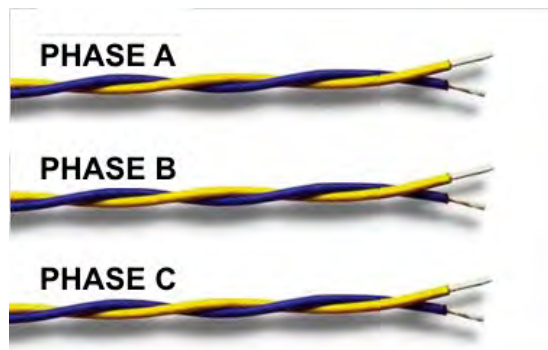

4. Avoid overload of power wires

Note: External voltage sense connections are at the programmed output voltage when the output is on so DO NOT connect or disconnect the external voltage sense lines while the AC power source is in use.

AFX L Version units are shipped with the mating sense connector installed but no wires to prevent contact with the sense connections. AFX A Version units don't require a mating connector.

7.3 Auxiliary I/O

The Auxiliary I/O functions are **only** available on 3xx0AFX-2AG and 3xx0AFX-4AG version power source models.

7.3.1 Auxiliary I/O Functions

The Auxiliary I/O board when added to an AFX Series power source adds the following functions and features:

- Digital Inputs for trigger functions and control.
- Digital Outputs for status indication and relay control.
- Analog Inputs for control of power source parameters.
- Analog Outputs for measurement monitoring.
- A 12Vdc power output to power external circuits.
- RS232 Serial Interface.
- Optional embedded GPIB Control Interface

The analog, digital and RS232 ports are accessible on a female DB25 connector located on the rear panel of the AFX master unit. This connector is mounted upside down so pin 1 is located in the lower right-hand corner when facing the back of the AFX master unit.

The USB, LAN and optional GPIB connectors are located to the left of the AUX I/O connector on the rear panel when facing the power source from behind.

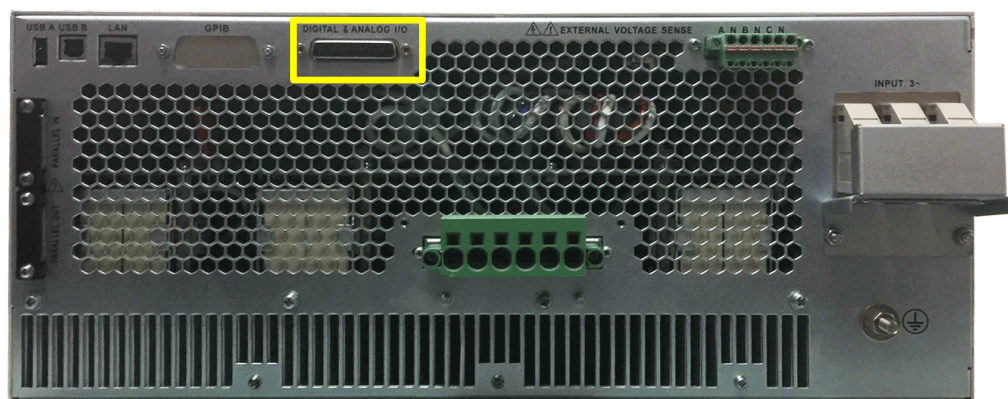

Figure 7-1: Rear Panel AUX I/O DB25 Connector Location

7.3.2 DB25 Connector AUX I/O Pin Locations

The pin locations for the various I/O signals on the DB25 connectors are shown in Figure 7-2 below. Note that the connector is installed “Upside” down due to mounting constraints.

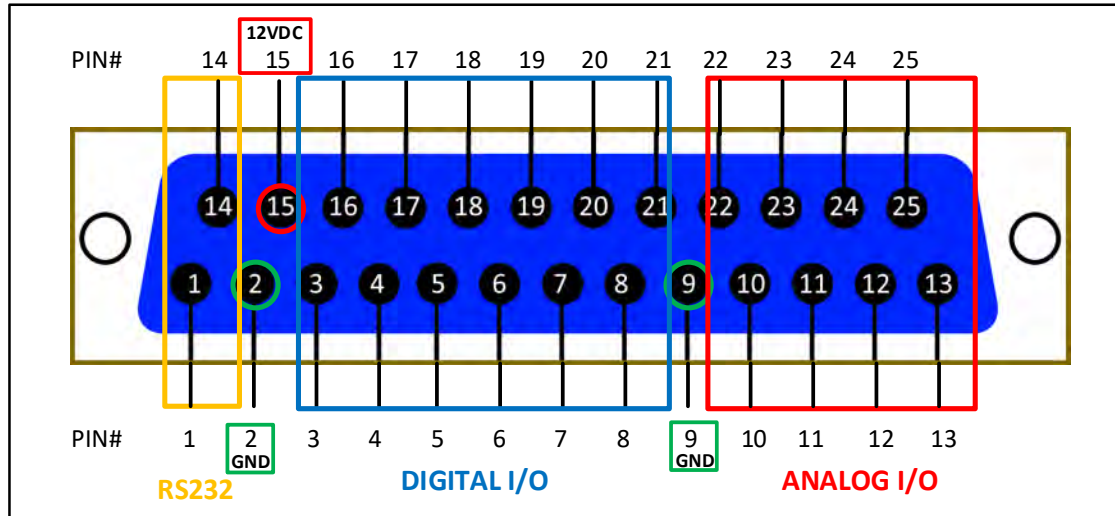

Figure 7-2: DB25 Connector AUX I/O Pin Locations

Functional grouping of pins by I/O function is done as shown in the figure above. The left hand side groups all **Analog I/O** signals on top on bottom row. The middle section is reserved for all **Digital I/O** pins. The **RS232** Transmit (Tx) and Receive (Rx) signals are located on the far left when facing the back of the unit.

7.3.3 I/O Signal Table by pin number

Pin assignments in order of pin number are shown in the table below.

Pin #	Name	Primary Function	Alternate Use / Comment	Type	Direction
1	RxD	RS232 Receive Data (Rx)		RS232	Input
2	GND	Chassis Ground		Ground	n/a
3	DI1	General Purpose Digital Input #1	Programmable	Digital	Input
4	DI2	General Purpose Digital Input #2	Programmable	Digital	Input
5	DI3	General Purpose Digital Input #3	Programmable	Digital	Input
6	RI	Remote Inhibit	Short to +12Vdc Pin 15	Digital	Input
7	TT	Transient Trigger Input		Digital	Input
8	Sync In	Phase Sync Input		Digital	Input
9	GND	Chassis Ground		Ground	n/a
10	AI1	Analog Input – Volt RMS Phase A	Any set point	Analog	Input
11	AI2	Analog Input – Volt RMS Phase B	Any set point	Analog	Input
12	AI3	Analog Input – Volt RMS Phase C	Any set point	Analog	Input
13	AI4	Analog Input – Current Limit RMS all phases	Any set point	Analog	Input
14	TxD	RS232 Transmit Data (Tx)		RS232	Output
15	12V	Output, 12Vdc	0.5 A max, current protected	Power	Output
16	DO3 /RC1	Relay Control #1 – FORM	Programmable, Open Collector, Current protected	Digital	Output
17	DO4 /RC2	Relay Control #2 - TRANSFORMER	Programmable, Open Collector, Current protected	Digital	Output
18	FS	Trigger Output / Function Strobe		Digital	Output
19	Sync Out	Phase Sync Output		Digital	Output
20	DO1	General Purpose Digital Output #1	Programmable	Digital	Output
21	DO2	General Purpose Digital Output #2	Programmable	Digital	Output
22	AO1	Analog output #1 – Volt RMS Measurements Phase A	Any other measurement	Analog	Output
23	AO2	Analog output #2 – Volt RMS Measurements Phase B	Any other measurement	Analog	Output
24	AO3	Analog output #3 – Volt RMS Measurements Phase C	Any other measurement	Analog	Output
25	AO4	Analog output #4 – Total Power (all phases combined)	Any other measurement	Analog	Output

Table 7-1: Auxiliary I/O DB25 Connector Pin numbers and Signals by DB25 pin number

7.3.4 I/O Signal Table by Function

Pin assignments in order of pin number are shown in the table below.

Pin #	Name	Primary Function	Alternate Use / Comment	Type	Direction
10	AI1	Analog Input – Volt RMS Phase A	Any set point	Analog	Input
11	AI2	Analog Input – Volt RMS Phase B	Any set point	Analog	Input
12	AI3	Analog Input – Volt RMS Phase C	Any set point	Analog	Input
13	AI4	Analog Input – Current Limit RMS all phases	Any set point	Analog	Input
22	AO1	Analog output #1 – Volt RMS Measurements Phase A	Any other measurement	Analog	Output
23	AO2	Analog output #2 – Volt RMS Measurements Phase B	Any other measurement	Analog	Output
24	AO3	Analog output #3 – Volt RMS Measurements Phase C	Any other measurement	Analog	Output
25	AO4	Analog output #4 – Total Power (all phases combined)	Any other measurement	Analog	Output
3	DI1	General Purpose Digital Input #1	Programmable	Digital	Input
4	DI2	General Purpose Digital Input #2	Programmable	Digital	Input
5	DI3	General Purpose Digital Input #3	Programmable	Digital	Input
20	DO1	General Purpose Digital Output #1	Programmable	Digital	Output
21	DO2	General Purpose Digital Output #2	Programmable	Digital	Output
18	FS	Trigger Output / Function Strobe		Digital	Output
16	DO3 /RC1	Relay Control #1 – FORM	Programmable, Open Collector, Current protected	Digital	Output
17	DO4 /RC2	Relay Control #2 - TRANSFORMER	Programmable, Open Collector, Current protected	Digital	Output
6	RI	Remote Inhibit	Short to +12Vdc Pin 15	Digital	Input
8	Sync In	Phase Sync Input		Digital	Input
19	Sync Out	Phase Sync Output		Digital	Output
7	TT	Transient Trigger Input		Digital	Input
15	12V	Output, 12Vdc	0.5 A max, current protected	Power	Output
2	GND	Chassis Ground		Ground	n/a
9	GND	Chassis Ground		Ground	n/a
1	RxD	RS232 Receive Data (Rx)		RS232	Input
14	TxD	RS232 Transmit Data (Tx)		RS232	Output

Table 7-2: Auxiliary I/O DB25 Connector Pin numbers and Signals by Signal Name

7.3.5 Dedicated Function Digital Inputs

- Remote Inhibit
- External Trigger Input
- External Phase Sync Input

7.3.5.1 Remote Inhibit

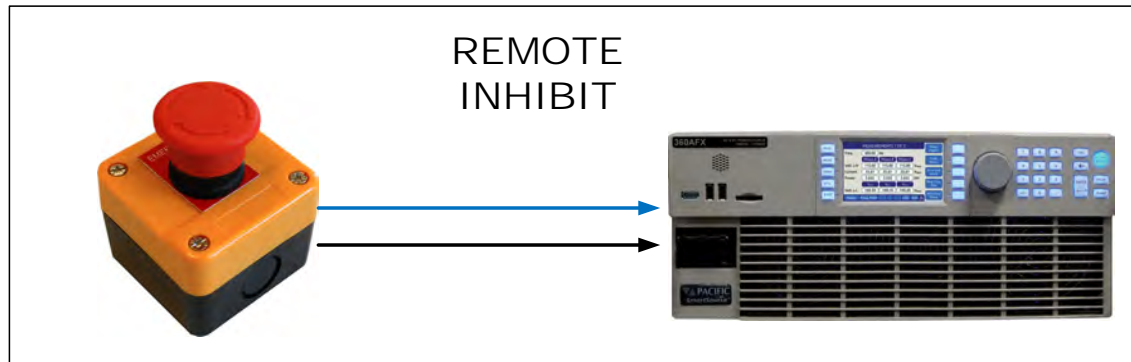

The mode can be selected from the SYST (SYSTEM) menu screen using the Interfaces, Remote Inhibit selection as shown below.

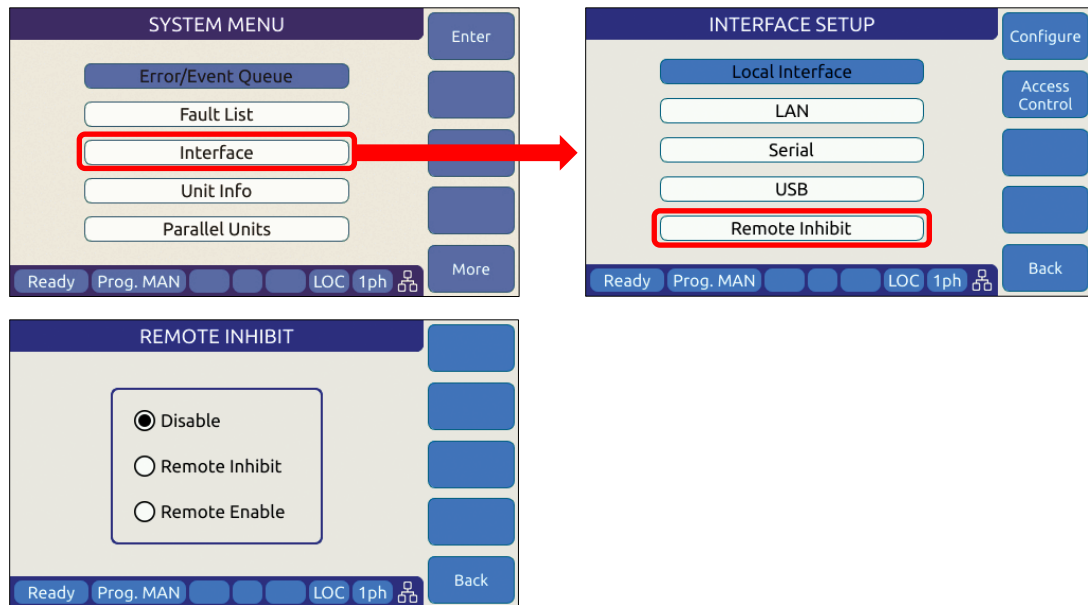

There are three modes of operation for this input:

4. **Disable mode:** In this mode, the Remote Inhibit inputs are not active so this function is turned off. No short between the RI pins is required to enable the output in this mode.

5. **Remote Inhibit mode:** The Remote Input pins 6 and 15 on the rear panel DB25 AUX I/O connector have to be shorted for the output to be enabled from the front panel or remote command. This is a necessary but not a sufficient condition to enable the output. If the output is enabled and the remote inhibit connection is open, a fault is generated. This mode is recommended for interlock safety applications such as safety cages and test fixture interlocks.

Command: SYSTem:DIO:REMOte:INHibit 0 | 1

6. **Remote Enable mode:** The output can be enabled by shorting pins 6 & 15 on the rear panel DB25 AUX I/O connector, regardless of the output enable command/button. It is a sufficient condition to enable the output.

Command: SYSTem:DIO:REMOte:ENABle 0 | 1

This function can be enabled or disabled at power on using

Command⁷: SYSTem:DIO:REMOte:ENABle:AUTO 0 | 1 (default = 1)

When AUTO is set to 1, output is enabled immediately after power up if the remote enable input is 1. When Auto is set to 0, output is enabled only when a 0 to 1 input level change is detected and disabled on a 1 to 0 level change.

Both settings can be changed by the user. Sending a sanitize command returns both back to 1 and 0 respectively.

Countdown beeping warning before enabling output, like a time boom. The warning pop-ups messages below are shown on LCD and webpage before enabling the output.

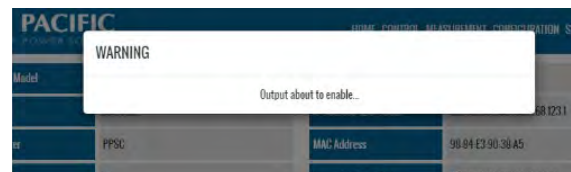
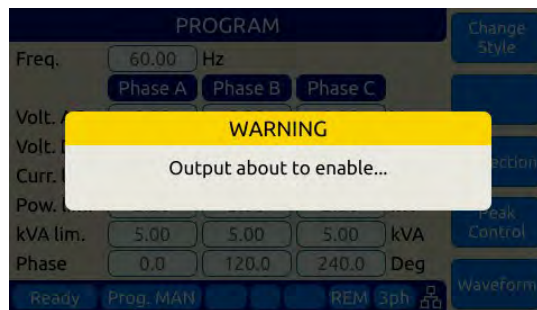

⁷ This command is supported with firmware revision 2.2.48 or higher only.

7.3.6 Transient Trigger Input

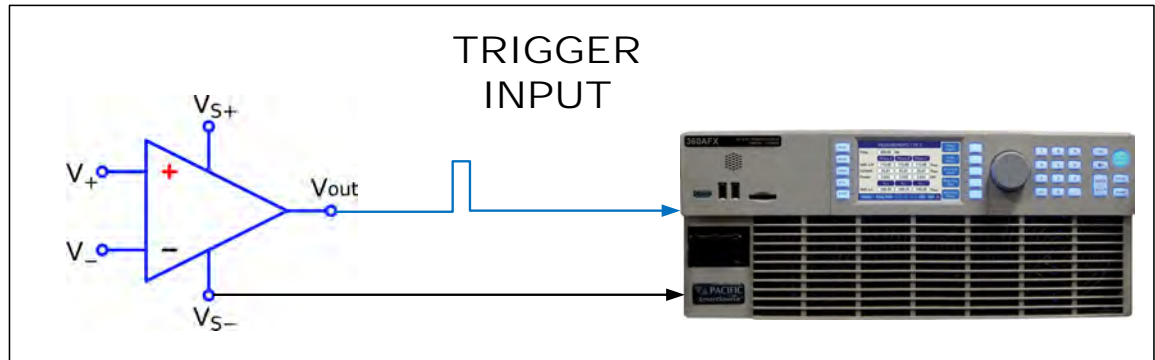

The external trigger input can be programmed to trigger the start of a transient program. This allows the power source output sequence to be initialized by an external sync signal.

In order to use the trigger input, the mode has to be active (from any of the graphical interfaces or using the SCPI command `PROG:TRANS:TRIG:IN`), and the transient program has to be executed first. The transient will wait and start execution when a rising edge is detected on this digital input.

The graphical interfaces (front panel and webpage) will show the state “Running” but with a progress of 0% until the transient program is actually started.

The following specifications apply to the external trigger input:

Input Voltage	Logic Low $V_{in} < 0.4\text{ V}$ Logic High $V_{in} > 2.0\text{ V}$
Impedance	10 k Ω
Edge Triggered	Rising edge

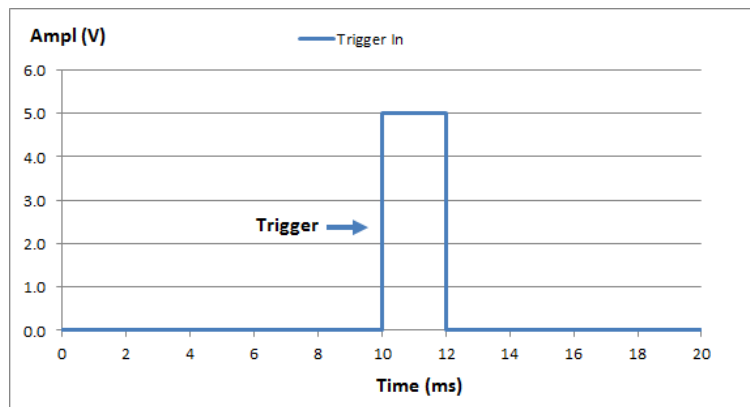
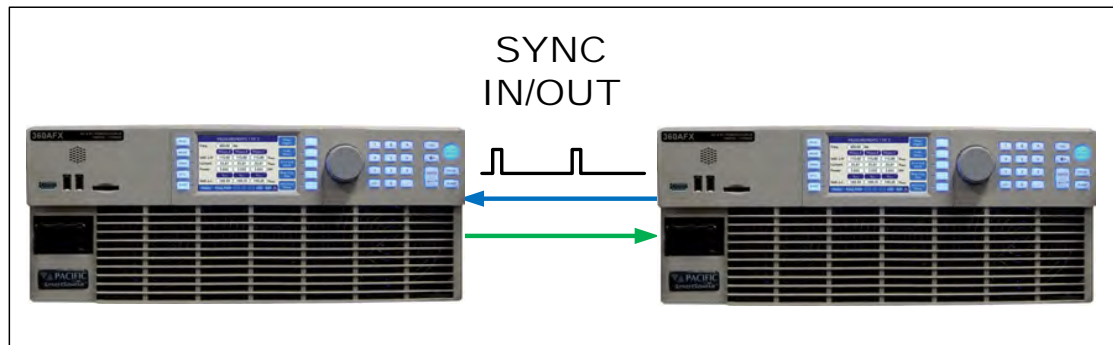

Figure 7-3: External Trigger Input Timing

7.3.7 External or Line Sync Input



The phase sync input can be used to synchronize in frequency and phase the internal waveform generation of the AFX to an external sync reference or to the AC mains. The reference must be within the specified frequency range of the power source and zero phase offset calibration for phase A may be required to compensate for any phase shifts. Note that Phase B and C are still phase related to A as programmed by B and C phase angles.

7.3.7.1 Principle of Operation

In AC Line sync mode, the AFX uses the L-L AC input voltage to generate the internal sync signal. The goal of the phase sync is to provide precise frequency synchronization, and consistent phase at a given operating point, but the phase shift between AC input and AC output is not automatically zero. A phase adjustment for Phase A must be made by the user to time-align the power source's phase A output voltage to the L1 leg of the actual three phase Grid voltage powering the AFX.

A couple of factors affect the phase shift:

- The internal AC sync circuits have some inherent delays. If more accuracy is required then the TTL input mode can be used instead using an external line sync circuit.
- Even if TTL input is used, there can be a phase shift that depends on the output load because of the finite bandwidth of the output inverter stages. This is particularly visible at higher frequencies. At 50Hz or 60Hz, the phase shift will be pretty small.

Note: When the sync input is enabled, the AFX frequency set point **must** be set to a value similar to the external sync signal. This minimizes the synchronization time and improves the stability of the generated frequency.

After the sync input is activated, or the external signal frequency/phase is changed, the Sync circuit's Phase Lock Loop (PLL) requires a short time to "lock" to the external source. The AFX reports the status of the PLL in the external interfaces (front panel and webpage) by showing a "Synced" or "Unsynced" message in the status bars.

The status can also be queried with the SCPI command "SOURCE:SYNChronize:STATE?".

The sync circuit is able to synchronize to any signal with a frequency if $F_{\text{SETPOINT}} \pm F_{\text{RANGE}}$, where F_{SETPOINT} is the normal frequency set point and F_{RANGE} is a configurable value (default is 10Hz)

The following specifications apply to the phase sync input at the DB25 port:

Input Voltage	Logic Low $V_{in} < 0.4 \text{ V}$ Logic High $V_{in} > 2.0 \text{ V}$
Impedance	10 k Ω
Frequency Range	15 Hz – 1200 Hz
Edge Triggered	Rising edge

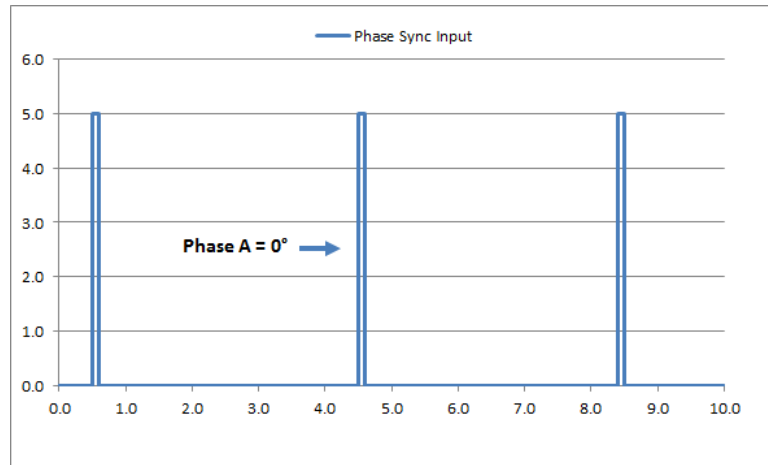

Figure 7-4: External Sync Input Pulses

7.3.7.2 SYNC Status Display

A “Synced” status field will be displayed in **Green** in the lower left corner of the LCD display. This field will toggle with the regular “Ready/Enabled/Fault” status field also shown in this location. The “Synced” status will be shown every 3 seconds for 1 second in place of the “Ready/Enabled/Fault” field. When the PLL is not locked to the external source, the unit will display an “Unsynced” status in **Orange**.

It is not recommended to enable the unit when it has not locked or synchronized to the external source because the frequency may be unknown.

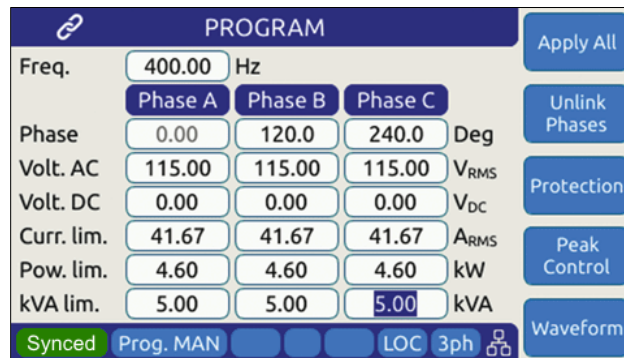

Figure 7-5: External Sync Input Sync Status Indication

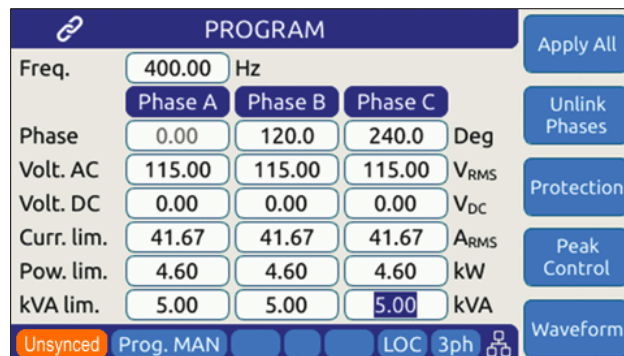

Figure 7-6: External Sync Input Sync Lost Status Indication

7.3.7.3 Sync Operation Settings

The AFX allows precise configuration of the synchronization parameters to optimize performance for each application. The parameters are:

- 1 **Phase shift:** Defines a fixed phase shift between phase A waveform generation and the external sync source. Used to calibrate any phase difference between the sync signal and the power source output on phase A.
Command: SOURce:SYNChronize:PHASEshift
- 2 **Speed:** Allows accelerating the speed of the internal synchronization engine (PLL) in case the external sync source is not constant and presents periodic or continuous

changes. A slower speed improves the stability of the waveform frequency, so it is recommended to use the smallest possible speed values.

Command: SOURce:SYNChronize:SPEed

- 3 **Range:** Allows configuration of how much the synchronization engine is able to deviate from the AFX programmed frequency. This helps to keep the waveform frequency under control, even if the external source is not present all the time. The synchronization engine is limited to frequencies of FSETPOINT +/- FRANGE.

Command: SOURce:SYNChronize:RANGe

7.3.8 Digital Output control signals

- External Relay Control #1 - FORM
- External Relay Control #2 - TRANSFORMER
- Trigger Output / Function Strobe
- Phase Sync Output

7.3.8.1 Function Strobe / Trigger Out

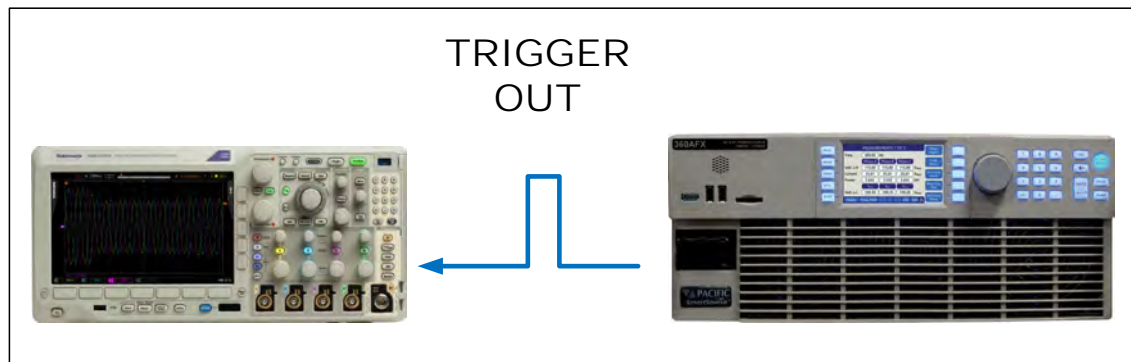

The external trigger output can be programmed to generate an output pulse on the following events:

- a. The start of a transient program (Transient Trigger)
- b. Output Replay State Change
- c. Any parameter change. Parameter changes that generate an output function strobe pulse are:
 - i. Voltage on any phase
 - ii. Frequency
 - iii. Waveform on any phase
 - iv. Phase angle

The mode can be set from the front panel or by using the following SCPI commands:

Transient start mode:	SYSTEM:DIO:STROBE:TRANSient 0/1	
	PROGram:TRANSient:TRIGger:OUTput 0/1	(alias)
Output Relay mode:	SYSTEM:DIO:STROBE:OUTPutstate 0/1	
Program Change mode:	SYSTEM:DIO:STROBE:SOURce 0/1	

The following specifications apply to the external trigger output:

Output Voltage @ 0.4 mA	Logic Low Vout < 0.4 V	
	Log High Vout > 4.6 V	
Max. Current	± 10 mA	
Output Impedance	100 Ω	
Pulse Width	190 us ± 10 us	For Transient Trigger mode
	2.0 msec ± 10 μs	For OUTPutstate & SOURce modes

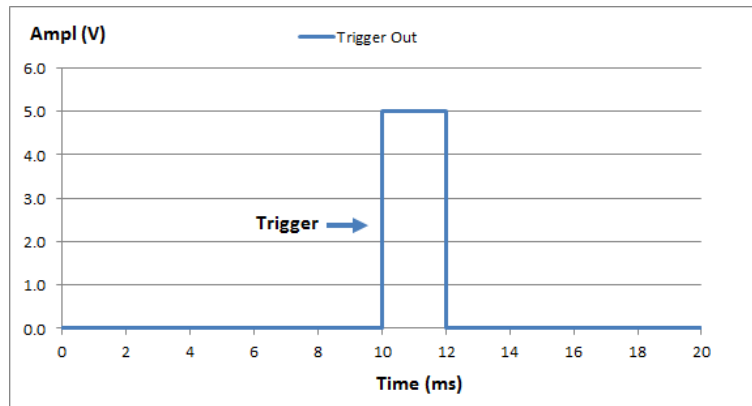

Figure 7-7: Transient Trigger Output Pulse

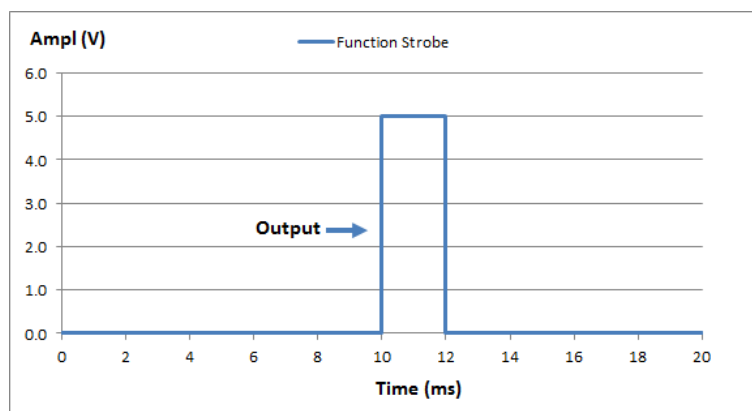
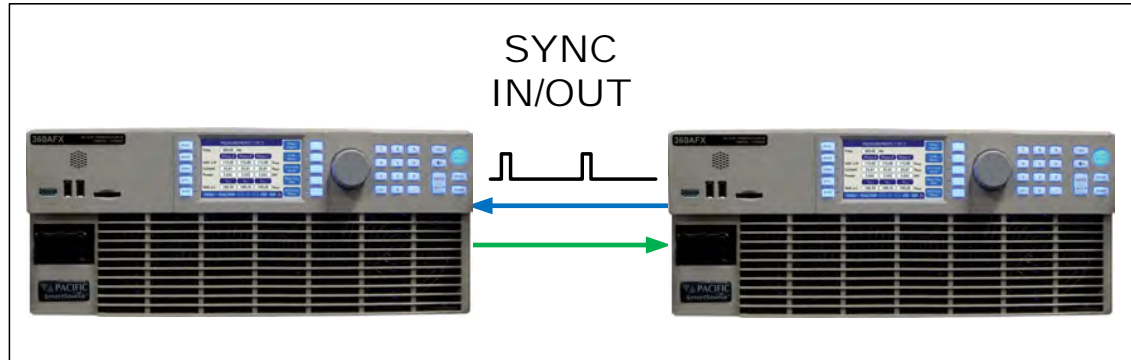

Figure 7-8: Function Strobe Output Pulse

7.3.8.2 Phase Sync Output



The phase sync output signal can be programmed to generate an output pulse at each zero crossing of the phase A voltage. This indicates the 0° phase angle output on Phase A.

The mode can be set from the front panel or by using the following SCPI commands:

The following specifications apply to the external trigger output:

Output Voltage @ 0.4 mA	Logic Low Vout < 0.4 V
	Logic High Vout > 4.6 V
Max. Current	± 10 mA
Output Impedance	100 Ω
Pulse Width	100 us ± 10 us

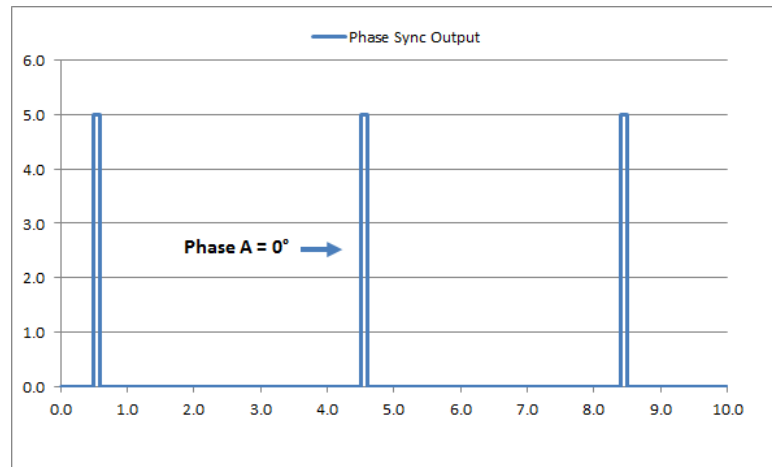
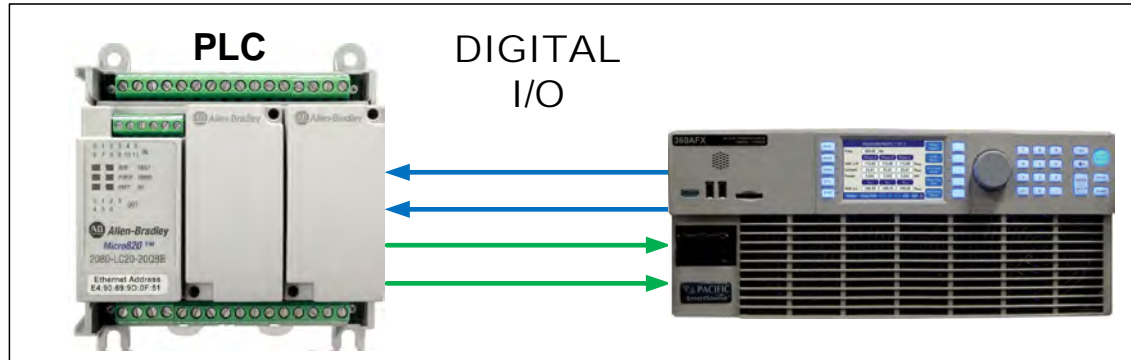

Figure 7-9: Phase A Zero Phase Sync Output Pulse

7.3.9 User Programmable Digital signals

Available user defined digital input and outputs are provided as part of the I/O feature. These signals may be assigned different purposes under software control.



User Programmable Digital Input signals functions are:

- DIO:INput1 - Digital Input #1
- DIO:INput2 - Digital Input #2
- DIO:INput3 - Digital Input #3

User Programmable Digital Output control signals are:

- DIO:OUTput1 - Digital Output – TTL level
- DIO:OUTput2 - Digital Output – TTL level
- DIO:OUTput3 - Digital Output – Open drain
- DIO:OUTput4 - Digital Output – Open drain

Digital outputs 3 and 4 are open drain with internal +5Vdc pull-ups.

7.3.9.1 Relay Control Outputs

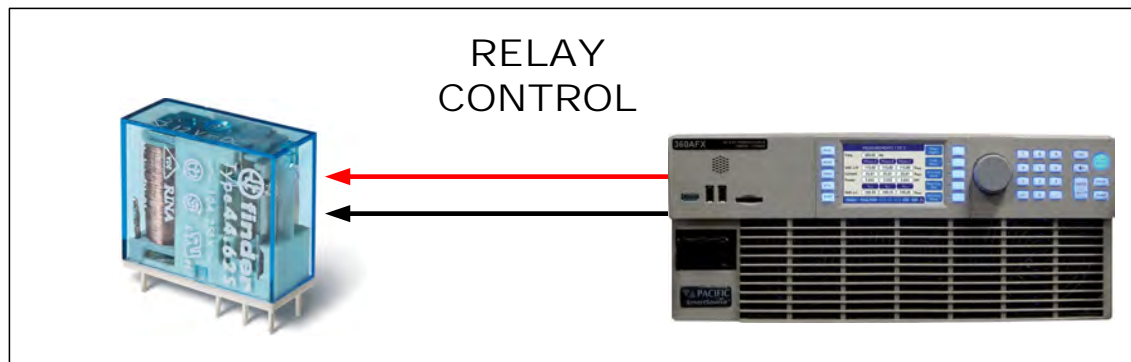

The external relay control output signals DO3 and DO4 can be used to control external relays. These control lines are user programmable for difference functions such as FORM relay control and Transformer Option control.

These relays are used to either short all outputs together for single-phase output mode or to connect and disconnect an external transformer for a higher voltage AC output range.

- Relay signal #3 is normally used for the FORM (Mode Change) Relay option on AFX cabinet systems.
- Relay signal #4 is normally used for the Transformer Option.
- A 12V dc output is provided as well to drive a small signal relay to operate a large contactor.

7.3.9.2 Digital User Inputs

The digital inputs allow any action to be executed at the rising and/or falling edge of the signal, by simply assigning a SCPI command for execution to that event.

For example, a digital input can be configured to enable the output at the rising edge and disable it at the falling edge of the signal. Alternatively, it can be configured to change any set point and either of those 2 events.

A total of three digital inputs are available. The following input characteristics can be programmed for each digital input (1, 2 and 3):

- **Command** to execute (a SCPI command string) at each edge. Rising and falling edges can have different commands.
- **Filter** Setting, to reduce sensitivity to short pulses that can be caused by electrical noise or some mechanical switches.

See SCPI command section 8.10.1.3 for commands that configure and read digital inputs.

7.3.9.3 Digital User Outputs

There are four programmable digital outputs (1 to 4), which can be configured to change state based on different conditions:

- 1=ON, 0=OFF it is used as general-purpose digital output, with the value set with a SCPI command.
- OUTPUT_STATE indicates output enabled (1) or disabled (0).
- FORM indicates single (1) or split/three (0).
- FAULT indicates fault (1) or no fault (0).
- TRANSIENT indicates when a transient is running/paused/stepping (1) or stopped (0).
- PROGRAM indicates when a program is in execution at steady state level (1) or manual mode (0).
- REMOTE indicates remote (1) or local (0).
- XFMR_COUPLING indicates direct (0) or transformer (1) coupling. This output is relevant only when an output transformer option is installed and configured.

Note: Each output can be also configured to invert its logic.

User defined digital inputs can be queried using the SYSTEM:DIO:OUTput# command.

Digital outputs 1 and 2 are TTL level signals (0 to 5V), and digital outputs 3 and 4 are open-drain type outputs (with an internal pull-up) that can be used to drive external relays. Each open-drain output has a current protection of 0.5A and internal clamping diode prepared to drive a relay coil.

See section 8.10.1.4 for commands that configure and read digital outputs.

7.3.10 Analog I/O Descriptions

Both analog inputs and outputs are available on the AUX I/O feature. Analog inputs are used to change output parameters such as voltage or frequency. Analog outputs are provided to allow monitoring the AFX measurements using external equipment.

7.3.10.1 Analog Inputs

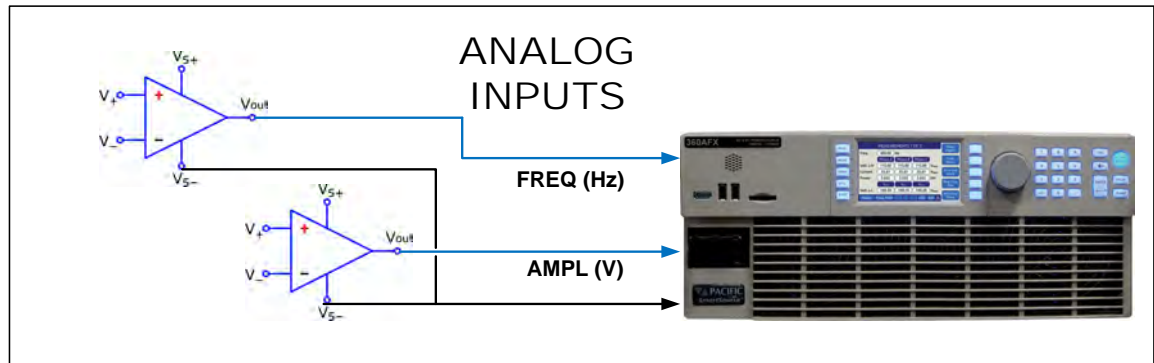

There are 4 analog inputs that accept DC signals up to 10Vdc and may be used to program the AFX output parameters such as voltage, frequency, current and power limits. Negative voltages of up to -10Vdc can be used to program DC voltage.

These inputs are sampled 20 times per second so updates of the assigned parameters occur at this rate. The full-scale range of the analog inputs can be programmed to be 5V, 10V or any value between 1 and 10V.

Note: Once enabled, make sure the input is not left floating or a small offset of about 2 to 3 % of full scale may be present affecting the programmed parameter. For example, when programmed to control AC voltage, no input on the analog input assigned will result in an output voltage of about 0.02 to $0.03 \times 300 = 6$ to 9 Vac.

The full-scale value for voltage programming depends on the selected operating mode. In AC and AC+DC modes, 10V input represents 300Vac RMS. In DC mode, ± 10 V input represents ± 425 Vdc.

For frequency programming, 0V represents 15Hz while 10V represents 1200Hz.

These analog inputs are all disabled by default. In order to use this feature, each analog input has to be assigned to an AFX parameter and phase, for example AC voltage of phase A.

7.3.10.2 Programming Analog Inputs

The range of the analog inputs can be changed with two parameters for each input, gain and offset. For example if an input is assigned to AC voltage programming the default gain is 300V and the offset is 0V. This means that 10V at the analog input port represents a programmed voltage of 300Vrms and 0V represents 0Vrms.

Different gain and offset combinations can be used to customize the range of the analog programming input, being the “gain” the programmed value that represents the maximum input at the analog port, and “offset” the value at 0V. For example, a gain of 150V and offset of 50V produce an output of 50V to 200V for analog programming signals of 0V to 10V.

Note: Different AFX parameters have different units (Volts, Amperes, Watts, Hertz, etc.), so when an analog input parameter is changed, the gain and offset are reset to default values (zero for offset and max full-scale values for gain).

7.3.10.3 Analog Outputs

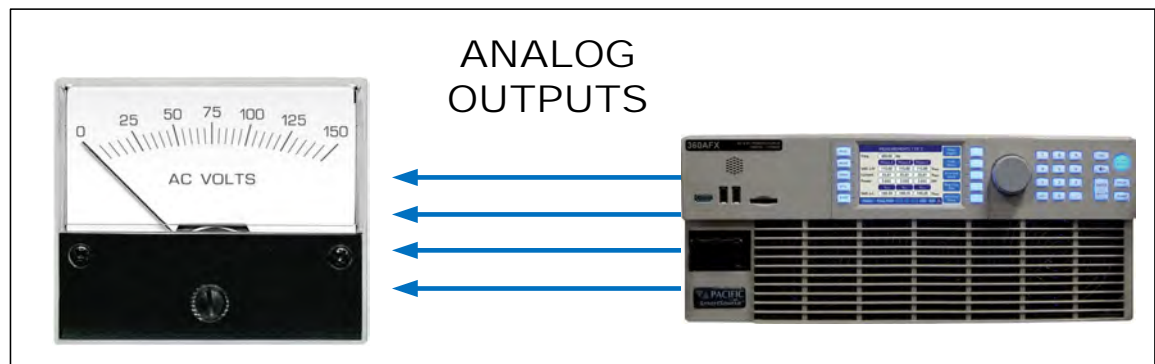

Analog outputs are available to monitor output values for voltage, current or power using external measurement equipment. A total of four analog outputs are provided, with an output voltage range of 0 to 5V. Output scaling is fully programmable for each measurement with an offset and gain.

For example, for RMS voltage measurements the default gain is 300V and offset is 0V. This means that measurements of 0 to 300V generate monitoring voltages of 0 to 5V. An offset of 50V and a gain of 150V will mean that measurements in the range of 50 to 200V will be mapped to the analog output range of 0 to 5V.

Analog outputs are available to monitor output values for voltage, current or power using external measurement equipment. A total of four analog outputs are provided. Output scaling is from 0 to 10V for zero to full scale.

Pin #	Signal	Programs
22	AO1	Volt RMS Measurements Phase A
23	AO2	Volt RMS Measurements Phase B
24	AO3	Volt RMS Measurements Phase C
25	AO4	Total Power (all phases combined)

Table 7-3: Default Analog Output Functions

7.3.11 12 DC Power Supply

A pin in the DB25 port provides a current limited, regulated 12V supply. The maximum current capability is 0.5A_{dc}.

There are no menus or commands associated with this output, as it is always active.

7.3.12 RS232 Description

The Tx and Rx signal on the AUX I/O connector may be used to connect to a serial port. Only Xon/Xoff handshake mode is supported on this RS232 port. For most situations, it is recommended to use the USB Device port for remote serial control applications.

7.3.13 Front Panel Operation of AUX I/O Functions

The auxiliary I/O functions can be configured and programmed from the front panel using the SYSTEM menu (Press SYST key to left of the LCD screen). This section describes the available AUX I/O program screens and parameters for each function.

7.3.13.1 Accessing AUX I/O Screens.

From the SYSTEM MENU, scroll to the INTERFACE entry and press the shuttle or ENTER key as indicated below. If the Interface selection is not visible, press the “More” soft key to display the second System Menu screen.

Next, scroll to the “Digital & Analog I/Os” entry at the bottom of the INTERFACE SETUP screen.

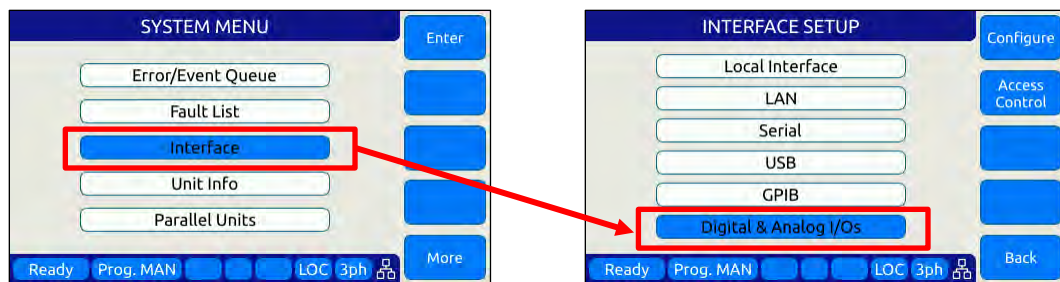

This will display a list of available Auxiliary I/O functions and features. To display the second of two DIGITAL & ANALOG I/Os screens, use the “More” soft key.



To select the desired function, use the knob to scroll up or down. Once selected, press the Shuttle knob or ENTER key to open the relevant I/O control screen.

Each screen is covered in the following sections in more detail.

7.3.13.2 Analog Inputs

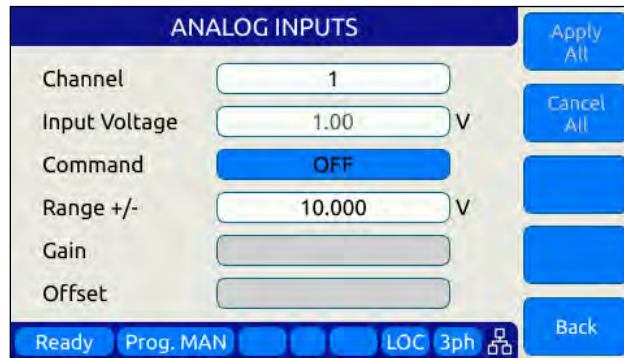

Analog inputs allow parameters settings to be controlled using DC input signals. The parameter to be controller by each of four available analog inputs can be assigned from the front panel.

Available settings or read-outs and parameter ranges are:

- CHANNEL [1 | 2 | 3 | 4]
- INPUT VOLTAGE Displays read back voltage
- COMMAND Select command from dropdown list or OFF for none. See table below
- RANGE 0.0000 to 10.000 V
- GAIN Gain
- OFFSET Offset value

The **Command** parameter allows the user to assign the selected analog input to the parameter that will be controlled by it. The list of available setting commands for these inputs is shown below.

Analog Input Command Values					
VOLT:AC	VOLT:DC	CURR:LIM	FREQ	KVA:LIM	POW:LIM
VOLT:AC1	VOLT:DC1	CURR:LIM1	PHAS2	KVA:LIM1	POW:LIM1
VOLT:AC2	VOLT:DC2	CURR:LIM2	PHAS3	KVA:LIM2	POW:LIM2
VOLT:AC3	VOLT:DC3	CURR:LIM3	OFF	KVA:LIM3	POW:LIM3

Table 7-4: AUX I/O Analog Input assignable Commands

The Gain and Offset parameters can be used to scale and shift the input value to the desired range for min. and max. output.

7.3.13.3 Analog Outputs

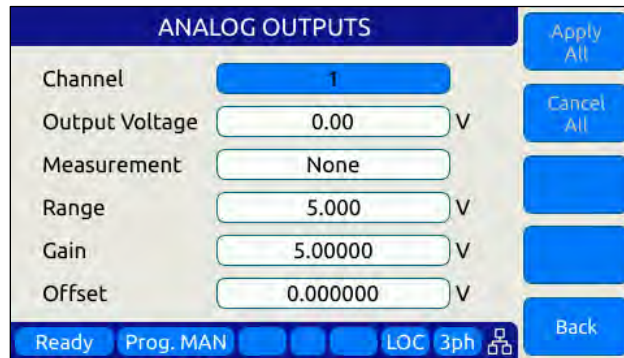

Analog outputs allow external equipment to monitor power source output values using an analog DC output signal. The assignment of measurement functions to each of four available outputs can be configured from the front panel.

Available settings are:

- CHANNEL [1 | 2 | 3 | 4]
- OUTPUT VOLTAGE Output setting
- MEASUREMENT Select measurement to be assigned to output
- RANGE 0.0000 to 5.000 V
- GAIN 0.000 to 1000
- OFFSET – 1000 to +1000

7.3.13.4 Digital Inputs

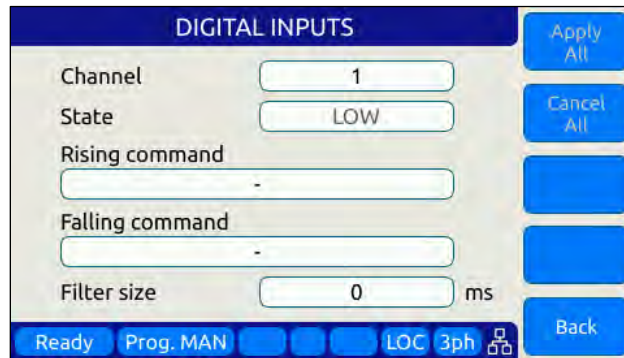

Digital Inputs allow external equipment such as PLCs. to control the power source operation. The assignment functions to each available input can be configured from the front panel.

Available settings are:

- CHANNEL [1 | 2 | 3]
- STATE Displays input state
- RISING CMD Set command string to execute on rising edge
- FALLING CMD Set command string to execute on falling edge
- FILTER SIZE 0 to 10,000,000 msec

7.3.13.5 Digital Outputs

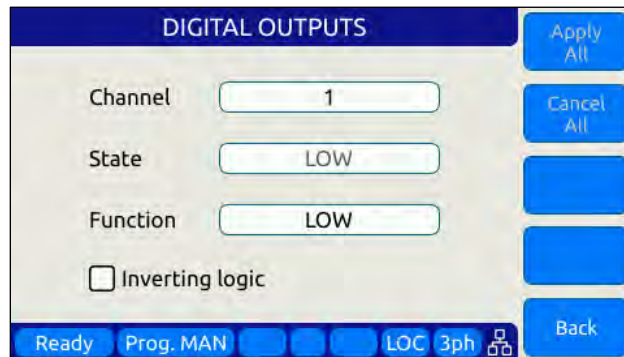

Digital Outputs can be used to trigger or control external equipment. The events assignable to each digital output can be selected using the **Function** field.

Available settings are:

- CHANNEL [1 | 2 | 3 | 4]
- STATE Displays current state
- FUNCTION Assigns state to selected channel. Available states are:
- INV. LOGIC [ON | OFF] Reverses polarity

Events that can be assigned to digital outputs are listed in the table below and can be set using the **Function** field.

Digital Output Assignable Events		
EVENT	Description	Indication
FAULT	Output goes high on fault event	1 = Fault occurred, 0 = No Fault
FORM	Output FORM state	1 = SINGLE, 0 = SPLIT/THREE
HIGH	Fixed Output high	1 = ON
LOW	Fixed Output low	0 = OFF
OUTPUT STATE	Output Relay State	1 = ON (enabled), 0 = OFF (disabled)
PROGRAM	Output goes high when Program is selected	1 = Steady State Program, 0 = Manual mode
REMOTE	Output goes high when unit is in REMOTE state	1 = REMOTE state, 0 = LOCAL state
TRANSIENT	Output goes high when transient is running	1 = Running/Paused/Stepping, 0 = Stopped
XFMR_COUPLING	Indicates output coupling mode	1 = Transformer Coupled, 0 = Direct Coupled

Table 7-5: AUX I/O Digital Output assignable Events or Conditions

7.3.13.6 Polarity Selection for DO3 and DO4 vs DO1 and DO2

The two open drain outputs DO3 and DO4 have internal 1 kΩ pull-up resistors to +5.5V. These outputs can be used as regular digital outputs (open-drain type) if needed. However, the logic will be inverted because a “direct” logic for the relay drive means an “inverted” logic for the open drain output. The FET being on means the relay coil active, but with a pull-up the output goes to low.

DO3 and DO4 use direct logic for the relay drive, which means that if the inverting logic is not active and there is a “1” written to the digital output, an internal FET will be activated causing a “low” in the open drain output.

Each digital output can be configured to have separate inverting logic, so the user can configure these 2 to be inverting and have the normal direct logic when used as open-drain outputs.

7.3.13.7 External Sync

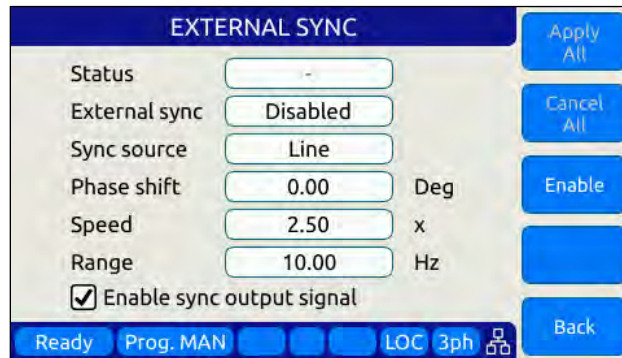

External sync is used to synchronize the power source’s phase A output to an external frequency.

Available settings are:

- STATUS Display SYNC Status
- EXTERNAL SYNC [ON | OFF]
- SYNC SOURCE Select Sync source
- Available sync sources are:
 - External sync input on I/O connector
 - LINE (AC input to power source)
- PHASE SHIFT Offset Phase A angle
- SPEED 1.00 to 10.00
- RANGE 0.10 to 500 Hz
- EXTERNAL SYNC [ON | OFF]

7.3.13.8 Trigger Input

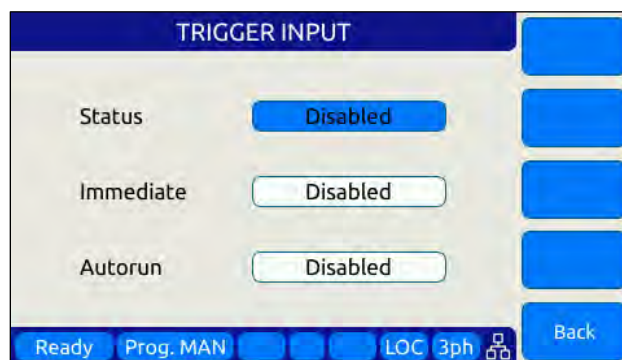

The External Trigger Input can be used to synchronize the power source’s transient execution to external equipment. This

Available settings are:

- STATUS [ON | OFF] Enabled or disabled

- IMMEDIATE [ON | OFF] Ignore phase update setting if ON
- AUTORUN [ON | OFF] No RUN command required if ON

7.3.13.9 Strobe Output

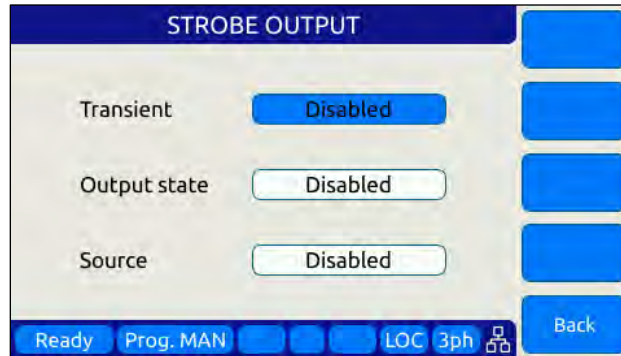

The Strobe Output is used to synchronize or trigger external equipment to an event occurring on the AC power source.

Available settings are:

- TRANSIENT ON = Strobe output on transient start
- OUTPUT STATE ON = Strobe output on relay close
- SOURCE ON = Strobe output on any program parameter change

7.3.13.10 Remote Control

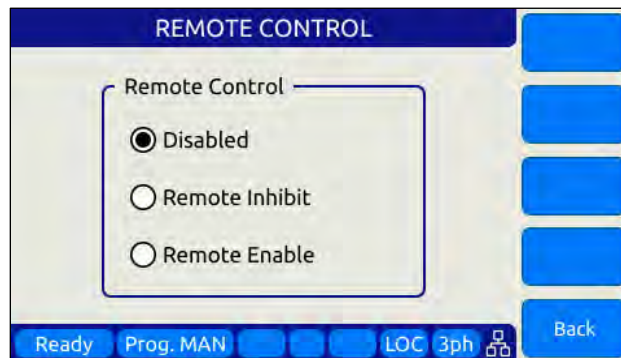

The remote control input is used to control operation of the output relay.

Available settings are:

- DISABLED No remote output control
- REMOTE INHIBIT Contact closure needed to close output relay
- REMOTE ENABLE Contact closure or front panel can control output relay

See Section 6.8.5.6.

7.4 System Interface Bus Connectors



CAUTION

SHOCK HAZARD: DO NOT remove safety covers from the two System Interface DVI Connectors.



AVERTISSEMENT

RISQUE DE CHOC: NE PAS retirer les capots de sécurité des deux connecteurs d'interface DVI

The system interface bus is not user-accessible. It consists of two Digital Visual Interface (DVI-I dual link) connectors that are covered by a protective cover. There are no user accessible signals on the system interface bus. It is used for system configuration cabinet systems only.

8 Remote Control Programming

8.1 Overview

If your unit is fitted with a computer interface option then RS232, USB or LAN connector will be present on the rear panel based on the order configuration. The interface allows the power source settings to be configured remotely and measurement data to be retrieved for analysis and test report generation.

The front panel LOCAL key allows the user to restore LOCAL CONTROL unless the Bus controller has sent a LOCAL LOCKOUT (LLO) message. The Bus Controller may restore LOCAL CONTROL by sending a GOTO LOCAL (GTL) message.

8.1.1 Programming Conventions and Notations

The following conventions and notations are used in this section of the manual:

1. COMMANDS are shown in the left hand column in BOLD with NO underline.
2. Command DESCRIPTIONS appear in the right hand column.
3. SCPI is "Standard Commands for Programmable Instruments -1992". Refer to the SCPI 1992 standard for more information. The full standard publication is available from the IVI Foundation at <http://www.ivifoundation.org/>
4. Some SCPI keywords are optional, and are ignored by the device. Optional keywords are enclosed in [] brackets.
5. Lowercase letters of commands shown are also optional.
6. The SCPI standard requires uppercase text in all SCPI commands (start with :), however, the command parser is not case sensitive and will accept commands sent in lower case. It is recommended that programming formats follow the SCPI standard.
7. Some SCPI commands have query command counterparts as noted. A query command consists of the command with a question mark (?) appended at the end. Parameters cannot be sent with a query. IEEE-488.2 commands do not have query counterparts unless explicitly shown with a question mark appended.
8. IEEE488.2 common commands start with an asterisk (*) and are not case sensitive.
9. All required Functional Elements for devices are implemented.
10. All numerical values are ASCII encoded decimal strings consisting of 1 or more ASCII digits. 8 and 16 bit register values are binary weighted values represented by an ASCII string of 1 or more decimal digits. One exception, the Serial Poll byte, is an 8 bit hexadecimal byte.
11. Multiple Commands and Queries may be sent in one Program Message but each must be separated by a semicolon (;). The term 'Program Message' refers to one or more

commands and/or queries sent to the controller as one continuous string and is not to be confused with Stored Programs (1-99) within the controller.

12. Multiple data parameter names and values must be separated by commas.
13. Voltage and Waveform parameter names without a channel number suffix (1,2,3) may be used to set all 3 channels (phases) simultaneously, as an alternative to setting each separately to the same value.
14. Multiple keyword messages may be sent without duplicating the first level SCPI keyword i.e., SOURce).
e.g., :SOURce:VOLTage1,120; FREQuency 60 >> Space Char before paramters
Alternative allowed: :SOURce:VOLTage1,120; FREQuency,60 >> Comma
A keyword is a single word beginning with a colon (:).
15. Program Messages MUST be terminated with a LINE FEED (0Ahex, 10dec) or END (EOI) signal. This is referred to as an end-of-string <eos>. A Carriage Return character (0Dhex, 13dec) is converted to a LINE FEED by the power source. Further SCPI commands shall begin with a first level keyword (i.e.,:SOURce:).
16. All values shown in angle brackets <> are examples of real values used with commands but labels are sometimes used to indicate a variable which is not known until actual time of use. e.g., <AMPS meter range> might actually be <50>. Units such as AAC, Hz. or % shown after the angle bracketed value are not to be included inside the value, but are shown as a reference to the units. The angle brackets are not part of the value.
17. The controller data input buffer is 8k bytes, as is its data output buffer. No program message may exceed this length.
18. All :SOURce: commands also support queries. An alternate method of writing or reading the presently active :SOURce:FORM, COUPLing, VOLTage, FREQuency, and CURRent:LIMit values is to use PROGram 0 (see examples). PROGram 0 contains the MANUAL MODE parameters.

NOTE: Sending any :SOURce: command invokes MANUAL MODE and REMOTE CONTROL.

19. Command strings may contain spaces.
20. The controller interface accepts IEEE-488.2 <nr1>, <nr2> and <nr3> numeric formats. Most query responses are <nr1> or <nr2> types. i.e., <nr1>=120, <nr2>=120.0, <nr3>=1.2E+02.
21. Follow any command (in the same Program Message) with *OPC to detect completion of the command or termination of a Transient event. An SRQ occurs when the command or Transient is complete (if ESB bit is set in SRE and OPC bit is set in ESE). *OPC? may be used in the same manner.

8.1.2 Command Terminators

Allowable terminator characters are:

Character	ASCII	Dec value	Hex value
Carriage Return	<CR>	13	0x0d
Line Feed	<LF>	10	0x0a

8.2 Remote Control Command Descriptions by Subsystem

This section covers detailed description of the available commands by category. The following command categories are defined.

Command Subsystem	Description
CALIBRATE	These commands perform calibration functions
MEASURE	These commands are used to measure voltage, current, power and any other measurement parameters from the instrument.
OUTPUT	These command control the power source output
PROGRAM	These commands control programmed settings and transient segments
SENSE	These commands control the voltage sense modes
SOURCE	These commands are used to set instrument settings
STATUS	These commands are used to control or query status and error messages.
SYSTEM	These commands are used to control system level setting such as interfaces, special operating modes or other special instrument specific functions.

Table 8-1: Available SCPI Command Subsystems

8.3 Calibration Commands

Calibration commands allow for fully automated calibration of the power source.

Note: It is not recommended for the end user to use these command unless calibration must be automated. Any errors in using these commands could invalidate user calibration data. Pacific Power Source recommends the use of a competent and authorized calibration lab to perform routine calibration.

The following calibration commands are supported. Commands marked “UPC” are provided for backward compatibility with UPC controller based PPS power sources.

8.3.1 AFX Calibration Commands

Command Syntax	CALibrate:COEFFicients:OFFSET:VOLTage
Description	Calibrates output DC voltage offset to lowest possible level.
Parameters	None
Parameter Format	n/a
Example	CAL:OFFSET:VOLT

Command Syntax	CALibrate:COEFFicients:OFFSET:CURRent
Description	Calibrates output DC current offset to lowest possible level
Parameters	None
Parameter Format	n/a
Example	CAL:OFFSET:CURR

Command Syntax	CALibrate:COEFFicients:NOISE:VOLTage
Description	Calibrates output voltage noise to lowest possible level.
Parameters	None
Parameter Format	n/a
Example	n/a

Command Syntax	CALibrate:COEFFicients:NOISE:CURRent
Description	Calibrates output current noise to lowest possible level.
Parameters	None
Parameter Format	n/a
Example	n/a

<p>Command Syntax Description</p>	<p>CALibrate:COEFFicients:GAIN:VOLTage[:AC] <cr> Loads values measured with an external DVM for calibration of AC voltage output and metering. The first 3 values are Voltages measured at the output relay of the power source for each phase. The second set of 3 values are Voltages measured at the external voltage sense points (at the load) for each phase.</p>
<p>Parameters Parameter Format Example</p>	<p>External reference voltage readings for each phase n/a n/a</p>
<p>Command Syntax Description</p>	<p>CALibrate:COEFFicients:GAIN:CURREnt[:AC] <cr> Loads values measured with an external shunt and DVM for calibration of AC current metering. The first 3 values are currents measured at the output of the power source for each phase.</p>
<p>Parameters Parameter Format Example Query Format Returned Data Format Query Example</p>	<p>External reference current reading n/a n/a No n/a n/a</p>
<p>Command Syntax Description</p>	<p>CALibrate:COEFFicients:GAIN:VOLTage:DC <cr> Loads values measured with an external DVM for calibration of DC voltage output and metering. The first 3 values are Voltages measured at the output relay of the power source for each phase. The second set of 3 values are Voltages measured at the EXTERNAL Sense point (at the load) for each phase</p>
<p>Parameters Parameter Format Example</p>	<p>None n/a n/a</p>
<p>Command Syntax Description</p>	<p>CALibrate:COEFFicients:GAIN:CURREnt:DC <cr> Loads values measured with an external shunt and DVM for calibration of DC current metering. The first 3 values are currents measured at the output of the power source for each phase.</p>
<p>Parameters Parameter Format Example</p>	<p>None n/a n/a</p>

Command Syntax	CALibrate:RESET
Description	Clears all calibration coefficients. Sending this command resets all calibration factors to defaults. After sending this command, programming and metering remains functional and will still meet spec.
Parameters	None
Parameter Format	n/a
Example	CAL:RESET
Query Format	CALibrate:COEFFicients:ALL?
Description	Returns all eighteen calibration factors as a comma delimited list.
Returned Data Format	<nr1>,...,<nr1>
Query Example	CAL:FACT:ALL? 0,0,0,0,0,0,0,0,0,0,0,0,0,0,0,0,0,0
Command Syntax	CALibrate:UPDATE
Description	Transfers cal factors from XML Calibration file to NVM. Required only if calibration.xml has been modified. Alternatively, the unit can be power cycled.
Parameters	None
Parameter Format	n/a
Example	n/a

8.3.2 UPC Mode Specific commands.

Following commands are included for UPC compatibility mode only and don't perform any function other than providing query responses for use with legacy software programs.

Query Format	CALibrate:VALue:XFMRRatio?
Query Format	CALibrate:VALue:AMPLIFIERS?
Command Syntax	CALibrate:KFACTORS <k_int_Va, k_int_Vb, k_int_Vc, k_ext_Va, k_ext_Vb, k_ext_Vc, k_la, k_lb, k_lc, k_oscA, k_oscB, k_oscC>
Query Format	CALibrate:KFACTors:ALL?

8.3.3 AUX I/O Interface Calibration Commands

For a list of AUX I/O calibration commands, see Section 8.10.4, "AUX I/O Calibration Command" on page 407.

8.4 Measurement Commands

Measurement commands are typically queries only and return power source measurement data values. This section is broken down into the commands for each measurement parameter.

The following measurement commands are supported.

8.4.1 Voltage Measurement Commands

Query Format	MEASure:VOLTage[:ACDC]#?
Description	Returns the measured RMS voltage for the selected phase #. If no phase number is specified, returns the reading for all phases.
Returned Data Format	<nr2>
Query Example	MEAS:VOLT:ACDC2? 230.0000
Query Format	MEASure:VOLTage:DC#?
Description	Returns the measured DC voltage for the selected phase #. If no phase number is specified, returns the reading for all phases.
Returned Data Format	<nr2>
Query Example	MEAS:VOLT:DC1? 2.2500
Query Format	MEASure:VOLTage:AC#?
Description	Returns the measured RMS voltage for the selected phase #. If no phase number is specified, returns the reading for all phases. This command is equivalent to “MEASure:VOLTage[:ACDC]#?” and is provided for backward compatibility with the UPC controllers.
Returned Data Format	<nr2>
Query Example	MEAS:VOLT:AC3? 230.0000
Query Format	MEASure:VLL#?
Description	Returns the measured RMS Line-to-Line voltage ¹ for the selected phase #. If no phase number is specified, returns the reading for all phases. Phase reference applies as follows: # = 1 V _{AB} , # = 2 V _{AC} , # = 3 V _{BC}
Returned Data Format	
Query Example	MEAS:VLL2? 398.3780

Note 1: Line to Line voltage measurements are calculated based on VLN and phase angles and are valid only for sinusoidal voltage waveforms with low levels of distortion and under balanced three phase load conditions.

8.4.2 Frequency Measurement Commands

Query Format	MEASure:FREQuency?
Description	Returns the fundamental frequency.
Returned Data Format	<nr2>
Query Example	MEAS:FREQ? 50.0000

8.4.3 Current Measurement Commands

Query Format	MEASure:CURRent[:ACDC]#?
Description	Returns the measured RMS current for the selected phase #. If no phase number is specified, returns the reading for all phases.
Returned Data Format	<nr2>
Query Example	MEAS:CURR:ACDC1? 21.1587

Query Format	MEASure:CURRent:PEAK#[:ABSolute]?
Description	Returns the measured peak current value for the selected phase #. If no phase number is specified, returns the reading for all phases.
Returned Data Format	<nr2>
Query Example	MEAS:CURR:PEAK? 45.5845, 47.3213, 48,2234

Query Format	MEASure:CURRent:PEAK#[:ABSolute]:HOLD?
Description	Returns the measured peak hold current value for the selected phase #. If no phase number is specified, returns the reading for all phases. This reading accumulates the highest recorded absolute peak current until reset using the MEASure:CURRent:PEAK#:RESet command.
Returned Data Format	<nr2>
Query Example	MEAS:CURR:PEAK:HOLD? 58.5845, 57.3213, 58,2234

Query Format	MEASure:CURRent:PEAK#:MINimum?
Description	Returns the lowest measured peak current value for the selected phase #. If no phase number is specified, returns the reading for all phases.
Returned Data Format	<nr2>
Query Example	MEAS:CURR:PEAK:MIN? 1.0001, 0.8451, 0.4871

Query Format Description	MEASure:CURRent:PEAK#:MINimum:HOLD? Returns the lowest measured peak hold current value for the selected phase #. If no phase number is specified, returns the reading for all phases. This reading accumulates the lowest recorded absolute peak hold current until reset using the MEASure:CURRent:PEAK#:RESet command.
Returned Data Format Query Example	<nr2> MEAS:CURR:PEAK:MIN:HOLD? 1.0001, 0.8451, 0.4871
Query Format Description	MEASure:CURRent:PEAK#:MAXimum? Returns the highest measured peak current value for the selected phase #. If no phase number is specified, returns the reading for all phases.
Returned Data Format Query Example	<nr2> MEAS:CURR:PEAK:MAX? 45.5845, 47.3213, 48,2234
Query Format Description	MEASure:CURRent:PEAK#:MAXimum:HOLD? Returns the highest measured peak hold current value for the selected phase #. If no phase number is specified, returns the reading for all phases. This reading accumulates the highest recorded absolute peak hold current until reset using the MEASure:CURRent:PEAK#:RESet command.
Returned Data Format Query Example	<nr2> MEAS:CURR:PEAK:MAX:HOLD? 58.5845, 57.3213, 58,2234
Command Syntax Description	MEASure:CURRent:PEAK#:RESet This command resets all peak hold current readings for the selected phase # to zero. If no phase number is specified, returns the reading for all phases.to zero.
Parameters	None
Parameter Format Example	n/a MEAS:CURR:PEAK1:RES
Query Format Description	MEASure:CURRent:CREST#? Returns the measured current crest factor for the selected phase #. If no phase number is specified, returns the reading for all phases.
Returned Data Format Query Example	<nr2> MEAS:CURR:CREST1? 2.1544

Query Format Description **MEASure:CURRent:DC#?**
Returns the measured DC current for the selected phase #. If no phase number is specified, returns the reading for all phases.

Returned Data Format <nr2>
Query Example MEAS:CURR:DC1?
0.0000

Query Format Description **MEASure:CURRent:AC#?"**
Returns the measured RMS current for the selected phase #. If no phase number is specified, returns the reading for all phases. This command is equivalent to "MEASure:CURRent[:ACDC]#?" and is provided for backward compatibility with the UPC controllers.

Returned Data Format <nr2>
Query Example MEAS:CURR:AC1?
21.1587

8.4.4 Power Measurement Commands

Query Format Description **MEASure:POWer#?**
Returns the true power for the selected phase # in kW. If no phase number is specified, returns the reading for all phases.

Returned Data Format <nr2>
Query Example MEAS:POWer1?
4.4203

Query Format Description **MEASure:POWer:MAXimum:HOLD?**
Returns the highest total power reading obtained for all phases. The reset this track and hold value, use the MEASure:POWer:RESET command.

Returned Data Format <nr2>, <nr2>, <nr2>
Query Example MEAS:POW:MAX:HOLD?
4800.0000, 4780.0000, 4687.0000

Query Format Description **MEASure:POWer:MINimum:HOLD?**
Returns the lowest total power reading obtained for all phases. If this command returns a **negative** value, then power has been fed back into the power source. For non-regenerative power sources, the ability to absorb energy from the load is very limited and the unit may FAULT. The reset this track and hold value, use the MEASure:POWer:RESET command.

Returned Data Format <nr2>, <nr2>, <nr2>
Query Example MEAS:POW:MIN:HOLD?
200.0000, -190.0000, 230.0000

Command Syntax **MEASure:POWER:RESET**
Description Clear the track and hold MINimum and MAXimum power hold readings.
Returned Data Format <nr2>
Query Example MEAS:POWer1?
4.4203

Query Format **MEASure:KVA#?**
Description Returns the true apparent for the selected phase # in kVA. If no phase number is specified, returns the reading for all phases.
Returned Data Format <nr2>
Query Example MEAS:KVA1?
4.8665

Query Format **MEASure:PF#?**
Description Returns the true apparent for the selected phase # in kVA. If no phase number is specified, returns the reading for all phases.
Returned Data Format <nr2>
Query Example MEAS:PF1?
0.9083

8.4.5 KWh Measurement Commands

Query Format **MEASure:KWHour#?**
Description Returns the accumulated energy measurement for the selected phase # in kWh. If no phase number is specified, returns the total summed kWh for all phases.
Returned Data Format <nr2>
Query Example MEASure:KWHour?
12.4203

Command Syntax **MEASure:KWHour:RESET**
Description This command resets all energy measurements to zero and resets the time counter.
Parameters None
Parameter Format n/a
Example MEAS:KWH:RESET

Query Format **MEASure:KWHour:ETIME?**
Description This command returns the accumulated energy measurement time in seconds.
Returned Data Format <nr2>
Query Example MEAS:KWH:ETIM?
120.5

Command Syntax	MEASure:KWHour[:STAtE]
Description	This command enables or disables the KWh measurements. When enabled, the energy time counter starts till reset with the MEASure:KWHour:RESET command.
Parameters	< 1 ON 0 OFF >
Parameter Format	
Example	MEAS:KWH ON
Query Format	MEASure:KWHour[:STAtE]?
Description	The query format of this command returns the setting of the KWh measurement as either 1 (ON) or 0 (OFF).
Returned Data Format	<nr1>
Query Example	MEAS:KWH? 1

8.4.6 Other Measurement Commands

Query Format **MEASure:TEMPerature:AMBient?**
 Description Returns the ambient temperature of the power source in degrees celcius.
 Returned Data Format <nr1>
 Query Example MEAS:TEMP:AMB?
 24

Query Format **MEASure:ALL#?**
 Description Returns 14 parametric measurements for the selected phase # as a comma delimited string. The # is used to specify phase A, B or C using 1, 2 or 3 respectively. If phase reference is omitted, measurement data for all three phases is returned. Value order for each phase is:

All Firmware Revisions	
1. Frequency (repeats for each phase)	2. VLL AC+DC
3. VLL AC RMS	4. VLL DC
5. VLN AC+DC	6. VLN AC
7. VLN DC	8. I AC
9. I DC	10. POWER
11. APP POWER	12. I PEAK
13. PF	14. CF
FW Rev 2.0.0 ~ 2.2.15	
15. PEAK CURRENT	16. KWH
17. Elapsed Time for KWH	
FW Rev 3.3.12	
15. PEAK CURRENT	16. VOLTAGE THD
17. CURRENAT THD	18. PF Angle
19.DISPLACEMENT FACTOR	20. DISTORTION FACTOR
21. KWH	22. Elapsed Time for KWH

Thus, each phase data set consists of 14 values. For all phases, a total of 42 comma separated values are returned.

Returned Data Format <nr2><nr2>,<nr2>,<nr2>
 Query Example MEAS:ALL1?
 1200.0000,519.5981,519.5981,0.0028,299.9990,299.9989,-
 0.0007,0.1711,-0.0016,0.0000,0.0513,0.4849,0.0000,0.0000

Query Format **MEASure:ALL:CATALOG?**
 Description Returns a comma-separated human-readable list of available measurements in the same order as the command returns it. See MEASure:ALL#? Command for parameter list as a function of Firmware revision.
Note: Available in FW Revisions 2.2.16 / 3.3.13 or higher.

Query Format	MEASure:ALL#? <OPTIONAL: List of measurements to return>
Description	Same as MEASure:ALL#? Command with optional user specified parameters list. Query command returns measurement parameters as included in list in the order they are specified by the list.
	Note: Available in FW Revisions 2.2.16 / 3.3.13 or higher.

8.4.7 Measurement Data Logging Commands

Command Syntax	MEASure:LOGger:START
Description	Starts the logging of measurements process. The process consists of taking measurements and saving them in a file. The log file can be found in the “datalogger” folder and is a comma separated value format (.csv) file. Measurements will be taken while the output is enabled only.
Parameters	None
Parameter Format	n/a
Example	MEAS:LOG:START
Query Format	None

Command Syntax	MEASure:LOGger:STOP
Description	Stops the logging process that was started with MEASure:LOGger:START.
Parameters	None
Parameter Format	n/a
Example	MEAS:LOG:STOP
Query Format	None

Query Format	MEASure:LOGger:STATe?
Description	Returns the state of the measurement data logging process as a number as follows: 0 – Stopped 1 – Running 2 – Paused
Returned Data Format	<nr1>
Query Example	MEAS:LOG:STAT? 1

<p>Command Syntax Description</p>	<p>MEASure:LOGger:LIMit <cr> Sets the number of samples to get. Once the logging process reach this limit it will stop.If the limit is set as OFF or 0 it will not stop unless MEAS:LOG:STOP is executed. The limit can be specified as a number of samples or in seconds if a character "S" is added to the number. If the limit is passed as seconds, the command will compute the number of samples based on the logging rate. The formula is: number of samples = seconds / rate. The rate can be set with: MEASure:LOGger:RATE <nr1> or queried with: MEASure:LOGger:RATE?. < OFF 0 > XS where X is a time limit in seconds X where X is the limit in number of samples</p>
<p>Parameters</p>	
<p>Parameter Format Examples</p>	<p><cr> MEAS:LOG:LIM OFF MEAS:LOG:LIM 20S MEAS:LOG:LIM 100</p>
<p>Query Format Returned Data Format Query Example</p>	<p>MEASure:LOGger:LIMit? 0 MEAS:LOG:LIM? 10000</p>
<p>Command Syntax Description</p>	<p>MEASure:LOGger:FILELimit <nr1> Sets the limit of samples to save in the file. If the limit is reached and the logging process continues, a new file will be created.</p>
<p>Parameters</p>	<p>Limit in number of samples.</p>
<p>Parameter Format Example</p>	<p><nr1> MEAS:LOG:FILEL 100</p>
<p>Query Format Returned Data Format Query Example</p>	<p>MEASure:LOGger:FILELimit? <nr1> MEAS:LOG:FILEL? 10000</p>
<p>Command Syntax Description</p>	<p>MEASure:LOGger:FILENAME <cr> Sets the data logging file name</p>
<p>Parameters</p>	<p>Filename between double quotes</p>
<p>Parameter Format Example</p>	<p><cr> MEAS:LOG:FILEN "Measurement-AC+DC"</p>
<p>Query Format Returned Data Format Query Example</p>	<p>MEASure:LOGger:FILENAME? <cr> MEAS:LOG:FILEN? Measurement-AC+DC</p>

<p>Command Syntax Description</p>	<p>MEASure:LOGger:MEMory <cr> Select the memory where the logging files will be saved. By default it is RAM unless a memory stick or USB drive was inserted and selected with this command: MEAS:LOG:MEM:CAT? can be used to get the available memories. Memory name between double quotes.</p>
<p>Parameters Parameter Format Example Query Format Returned Data Format Query Example</p>	<p><cr> MEAS:LOG:MEM "USBA" MEASure:LOGger:MEMory? <cr> MEAS:LOG:MEM? USBA</p>
<p>Query Format Description Returned Data Format Query Example</p>	<p>MEASure:LOGger:MEMory:CATalog? Returns the catalog of available memory names. <cr> MEAS:LOG:MEM:CAT? RAM, USBA</p>
<p>Command Syntax Description</p>	<p>MEASure:LOGger:RATE Sets the frequency at which the logging process will take measurements.</p>
<p>Parameters Parameter Format Example Query Format Returned Data Format Query Example</p>	<p>Frequency in Hz. Range is 1 Hz through 10 Hz. <nr1> MEAS:LOG:RATE 5 MEASure:LOGger:RATE? <nr1> MEAS:LOG:RATE? 5</p>
<p>Command Syntax Description</p>	<p>MEASure:LOGger:TIMEstamp <cr> Sets the time stamp format that will be attached to every measurement record in the measurement log file.</p>
<p>Parameters Parameter Format Example Query Format Returned Data Format Query Example</p>	<p>< DATE 0 TIME 1 ALL 2 > <cr> MEAS:LOG:TIME ALL MEASure:LOGger:TIMEstamp? <nr1> MEAS:LOG:TIME? 2</p>

8.4.8 Waveform Capture Commands

Waveform capture commands may be used to retrieve time domain voltage and current waveform captures similar to those of a digital oscilloscope.

Query Format Description	<p>FETCH:WAVEform:VOLTage#? Returns time domain data for voltage on selected phase #. # = 1, 2 or 3. Returns a string of <nr2> type numbers, comma delimited. Only a single waveform may be queried in a command. Note: In UPC Compatibility mode, a total of 512 data points are returned. In AFX mode, 1024 data points are returned.</p>
Returned Data Format Query Example	<p><nr2>, <nr2>, <nr2>,....., <nr2> FETCH:WAVE:VOLT1? 0.000, 0.0001, 0.0003....., 0.000</p>
Query Format Description	<p>FETCH[:WAVEform]:VLL#? Returns time domain data for voltage on selected Line to Line voltage #. # = 1, 2 or 3. Returns a string of <nr2> type numbers, comma delimited. Only a single waveform may be queried in a command. Note: In UPC Compatibility mode, a total of 512 data points are returned. In AFX mode, 1024 data points are returned.</p>
Returned Data Format Query Example	<p><nr2>, <nr2>, <nr2>,....., <nr2> FETCH:WAVE:VLL1? 0.000, 0.0001, 0.0003....., 0.000</p>
Query Format Description	<p>FETCH:WAVEform:CURREnt#? Returns time domain data for current on selected phase #. # = 1, 2 or 3. Returns a string of <nr2> type numbers, comma delimited. Only a single waveform may be queried in a command. Note: In UPC Compatibility mode, a total of 512 data points are returned. In AFX mode, 1024 data points are returned.</p>
Returned Data Format Query Example	<p><nr2>, <nr2>, <nr2>,....., <nr2> FETCH:WAVE:CURREnt? 0.000, 0.0001, 0.0003....., 0.000</p>
Query Format Description	<p>FETCH:WAVEform:INFO? Returns the output measurement frequency, date and time of capture for the last waveform data fetched.</p>
Returned Data Format Query Example	<p><nr2>, <dd/mm/yyyy>, <hh:mm:ss> FETCH:WAVE:INFO? 400.000, "05/21/2018", "14:34:20"</p>

Query Format	FETCH:WAVEform:PERIOD?
Description	Returns the number of periods captured. Minimum period is 1, max no. of periods is 4.
Returned Data Format	<nr2>, <dd/mm/yyyy>, <hh:mm:ss>
Query Example	FETCH:WAVE:PERIOD? 400.000, "05/21/2018", "14:34:20"

8.4.9 Harmonic Measurements Commands

Harmonic Measurements commands may be used to retrieve harmonic analysis data for voltage and current. These measurements are returned using the SPECTrum commands.

<p>Query Format Description</p>	<p>MEASure:SPECTrum:VOLTage#[:MAGnitude]? Returns harmonics spectrum for voltage on selected phase #. # = 1, 2 or 3. Returns a data set of 51, <nr2> type numbers, comma delimited. The 1st element is the magnitude of the fundamental, for reference. The 2nd element is the 2nd harmonic, etc. Values represent % of fundamental (relative). Only a single spectrum may be queried in a command.</p>
<p>Returned Data Format Query Example</p>	<p><nr2>, <nr2>, <nr2>,....., <nr2> MEAS:SPECT:VOLT1? 100.000, 0.001, 0.3....., 0.000</p>
<p>Query Format Description</p>	<p>MEASure:SPECTrum:VLL#[:MAGnitude]? Returns harmonics spectrum for three phase Line to Line voltage on selected phase #. # = 1, 2 or 3 (1 = Vab, 2 = Vbc, 3 = Vac). Returns a VLL data set of 51, <nr2> type numbers, comma delimited. The 1st element is the magnitude of the fundamental, for reference. The 2nd element is the 2nd harmonic, etc. Values represent % of fundamental (relative). Only a single spectrum may be queried in a command.</p>
<p>Returned Data Format Query Example</p>	<p><nr2>, <nr2>, <nr2>,....., <nr2> MEAS:SPECT:VLL1? 207.000, 0.001, 0.3....., 0.000</p>
<p>Query Format Description</p>	<p>MEASure:SPECTrum:VLL#:ABSolute? Returns absolute harmonics spectrum for three phase Line to Line voltage on selected phase #. # = 1, 2 or 3 (1 = Vab, 2 = Vbc, 3 = Vac). Returns a VLL data set of 51, <nr2> type numbers, comma delimited. The 1st element is the magnitude of the fundamental, for reference. The 2nd element is the 2nd harmonic, etc. Values represent % of fundamental (relative). Only a single spectrum may be queried in a command.</p>
<p>Returned Data Format Query Example</p>	<p><nr2>, <nr2>, <nr2>,....., <nr2> MEAS:SPECT:VLL1:ABS? 207.000, 0.001, 0.3....., 0.000</p>

Query Format Description	<p>MEASure:SPECTrum:CURRent#[:MAGnitude]?</p> <p>Returns harmonics spectrum for current on selected phase #. # = 1, 2 or 3. Returns a data set of 51, <nr2> type numbers, comma delimited. The 1st element is the magnitude of the fundamental, for reference. The 2nd element is the 2nd harmonic, etc. Values represent % of fundamental (relative).</p> <p>Only a single spectrum may be queried in a command.</p>
Returned Data Format Query Example	<p><nr2>, <nr2>, <nr2>,....., <nr2></p> <p>MEAS:SPECT:CURR1?</p> <p>4.6300, 0.001, 0.23....., 0.000</p>
Command Syntax Description	<p>MEASure:SPECTrum:PHASe:REFerence</p> <p>This command sets the phase reference for the harmonic analysis measurement function.</p>
Parameters	<p>Available settings are:</p> <ul style="list-style-type: none"> 0 None. 1 (DEFAULT) All phases measurements are referenced to phase A voltage. 2 Voltage and current phases measurements are referenced to the voltage of the same phase (A, B or C) 3 Voltage phase measurements are referenced to the voltage of the same phase (A, B or C). Current phase measurements are referenced to the current of the same phase (A, B or C)
Parameter Format Example	<nr1>
Query Format	MEAS:SPECT:PHAS:REF 2
Returned Data Format	MEASure:SPECTrum:PHASe:REFerence?
Query Example	<p><nr1></p> <p>MEAS:SPECT:PHAS:REF?</p> <p>2</p>
Query Format Description	<p>MEASure:SPECTrum:PHASe?</p> <p>Returns phase angles in degrees for the most recent voltage or current spectrum query. Returns a data set of 51, <nr2> type numbers, comma delimited. The 1st element is the phase angle of the fundamental, for reference. The 2nd element is the phase angle of the 2nd harmonic, etc.</p>
Returned Data Format Query Example	<p><nr2>, <nr2>, <nr2>,....., <nr2></p> <p>MEAS:SPECT:PHAS?</p> <p>0.000, 20.000, 30.000....., 0.000</p>

<p>Query Format Description</p>	<p>MEASure:SPECTrum:VOLTage#:PHASe? Same as “MEASure:SPECTrum:PHASe?” but selects voltage and phase #. Returns phase angles in degrees for the most recent voltage spectrum query. Returns a data set of 51, <nr2> type numbers, comma delimited. The 1st element is the phase angle of the fundamental, for reference. The 2nd element is the phase angle of the 2nd harmonic, etc.</p>
<p>Returned Data Format Query Example</p>	<p><nr2>, <nr2>, <nr2>,....., <nr2> MEAS:SPECT:VOLT1:PHAS? 0.000, 20.000, 30.000....., 0.000</p>
<p>Query Format Description</p>	<p>MEASure:SPECTrum:VLL#:PHASe? Same as “MEASure:SPECTrum:PHASe?” but selects Line to Line voltage and phase #. Returns phase angles in degrees for the most recent voltage spectrum query. Returns a data set of 51, <nr2> type numbers, comma delimited. The 1st element is the phase angle of the fundamental, for reference. The 2nd element is the phase angle of the 2nd harmonic, etc.</p>
<p>Returned Data Format Query Example</p>	<p><nr2>, <nr2>, <nr2>,....., <nr2> MEAS:SPECT:VLL1:PHAS? 0.000, 20.000, 30.000....., 0.000</p>
<p>Query Format Description</p>	<p>MEASure:SPECTrum:CURREnt#:PHASe? Same as “MEASure:SPECTrum:PHASe?” but selects current and phase #. Returns phase angles in degrees for the most recent current spectrum query. Returns a data set of 51, <nr2> type numbers, comma delimited. The 1st element is the phase angle of the fundamental, for reference. The 2nd element is the phase angle of the 2nd harmonic, etc.</p>
<p>Returned Data Format Query Example</p>	<p><nr2>, <nr2>, <nr2>,....., <nr2> MEAS:SPECT:CURR:PHAS? 0.000, 20.000, 30.000....., 0.000</p>
<p>Query Format Description</p>	<p>MEASure:SPECTrum:THD? Returns Total Harmonic Distortion of the most recent :MEASure:SPECTrum:parameter command</p>
<p>Returned Data Format Query Example</p>	<p><nr2> MEAS:SPECT:THD? 2.5600</p>
<p>Query Format Description</p>	<p>MEASure:SPECTrum:VOLTage#:THD? Same as “MEASure:SPECTrum:THD?” but selects voltage and phase #.Returns Total Harmonic Distortion of the selected phase voltage.</p>
<p>Returned Data Format Query Example</p>	<p><nr2> MEAS:SPECT:VOLT1:THD? 2.5600</p>

Query Format	MEASure:SPECTrum:VLL#:THD?
Description	Same as “MEASure:SPECTrum:THD?” but selects Line to Line voltage #.Returns Total Harmonic Distortion of the selected Line to Line voltage.
Returned Data Format	<nr2>
Query Example	MEAS:SPECT:VLL1:THD? 2.5600
Query Format	MEASure:SPECTrum:CURREnt#:THD?
Description	Same as “MEAS:SPECTrum:THD?” but selects current and phase #.Returns Total Harmonic Distortion of the selected phase currebt.
Returned Data Format	<nr2>
Query Example	MEAS:SPECT:CURR1:THD? 2.5600
Query Format	MEASure:SPECTrum:EHD?
Description	Returns Even Harmonic Distortion of the most recent :MEASure:SPECTrum:parameter command
Returned Data Format	<nr2>
Query Example	MEAS:SPECT:EHD? 3.5690
Query Format	MEASure:SPECTrum:VOLTage#:EHD?
Description	Same as “MEAS:SPECTrum:EHD?” but selects voltage and phase #.Returns Even Harmonic Distortion of the selected phase voltage.
Returned Data Format	<nr2>
Query Example	MEAS:SPECT:VOLT1:EHD? 10.5891
Query Format	MEASure:SPECTrum:VLL#:EHD?
Description	Same as “MEAS:SPECTrum:EHD?” but selects Line to Line voltage #.Returns Even Harmonic Distortion of the selected Line to Line voltage.
Returned Data Format	<nr2>
Query Example	MEAS:SPECT:VLL1:EHD? 10.5891
Query Format	MEASure:SPECTrum:CURREnt#:EHD?
Description	Same as “MEAS:SPECTrum:EHD?” but selects current and phase #.Returns Even Harmonic Distortion of the selected phase currebt.
Returned Data Format	<nr2>
Query Example	MEAS:SPECT:CURR1:EHD? 22.5948

Query Format	MEASure:SPECTrum:OHD?
Description	Returns Odd Harmonic Distortion of the most recent :MEASure:SPECTrum:parameter command
Returned Data Format	<nr2>
Query Example	MEAS:SPECT:OHD? 3.5690
Query Format	MEASure:SPECTrum:VOLTage#:OHD?
Description	Same as “MEAS:SPECTrum:OHD?” but selects voltage and phase #.Returns Odd Harmonic Distortion of the selected phase voltage.
Returned Data Format	<nr2>
Query Example	MEAS:SPECT:VOLT1:OHD? 10.5891
Query Format	MEASure:SPECTrum:VLL#:OHD?
Description	Same as “MEAS:SPECTrum:OHD?” but selects Line to Line voltage #.Returns Odd Harmonic Distortion of the selected Line to Line voltage.
Returned Data Format	<nr2>
Query Example	MEAS:SPECT:VOLT1:OHD? 10.5891
Query Format	MEASure:SPECTrum:CURREnt#:OHD?
Description	Same as “MEAS:SPECTrum:OHD?” but selects current and phase #.Returns Odd Harmonic Distortion of the selected phase currebt.
Returned Data Format	<nr2>
Query Example	MEAS:SPECT:CURR1:OHD? 22.5948

8.4.10 Measurement Resolution Setting Commands

All SCPI measurement commands return measurement data in a format with a specific resolution, i.e. a certain number of digits after the decimal point. The default resolution (number of positions after the decimal point) for each parameter is chosen based on the dimension (VA or KVA) and measurement accuracy of that specific parameter.

The user can increase or decrease the number of digits for each measurement parameter if so desired by using the RESolution commands listed in this section⁸.

Note: Increasing the resolution of a measurement for any parameter does NOT improve the specified measurement's accuracy specification. As such, digits added for to any measurement may not represent meaningful information.

The generic format for this command is:

MEASure:MMMnnn:RESolution <RESOLUTION>

MEASure:MMMnnn:RESolution?

Where MMMnnn is the measurement command syntax of the measurement for which the resolution is to be set. The Query command can be used to query a command's active resolution setting.

<RESOLUTION> is a formatted number that specifies the number of digits to include in the query response. For example:

0.1	Only one digit behind the decimal point
0.0001	4 digits behind the decimal point
0.00001	6 digits behind the decimal point

Example:

MEASure:POWer:RESolution 0.00001

This changes the number of digits for True Power measurements from the default 4 to 5. Since Power measurements are reported in KW, this is equivalent to changing the measurement resolution from 0.1 W /10mW to 0.01W / 10mW. All these settings are independent of each other so only the specified measurement command's resolution will be changed. To change multiple commands, send this command for each one.

Note: Changing the resolution for any measurement command does NOT affect the displayed resolution of measurements in any of the power sources' front panel display screen. This command only affects remote control bus measurement queries.

Note: Once a command's resolution has been changed using the MEASure:MMMnnn:RESolution <RESOLUTION> command, the new resolution format is persistent, i.e. it remains in effect between power on/off cycles. To change it back, a new RESolution command must be sent.

⁸ Requires Firmware Revision 2.2.11 or higher

The following table shows the available RESolution commands.

Measurement Resolution Command	Query Format
MEASure:VOLTage:RESolution <RESOLUTION>	MEASure:VOLTage:RESolution?
MEASure:VLL:RESolution <RESOLUTION>	MEASure:VLL:RESolution?
MEASure:FREQuency:RESolution <RESOLUTION>	MEASure:FREQuency:RESolution?
MEASure:CURRent:RESolution <RESOLUTION>	MEASure:CURRent:RESolution?
MEASure:CURRent:CREST:RESolution <RESOLUTION>	MEASure:CURRent:CREST:RESolution?
MEASure:POWer:RESolution <RESOLUTION>	MEASure:POWer:RESolution?
MEASure:KVA:RESolution <RESOLUTION>	MEASure:KVA:RESolution?
MEASure:PF:RESolution <RESOLUTION>	MEASure:PF:RESolution?
MEASure:TEMPerature:RESolution <RESOLUTION>	MEASure:TEMPerature:RESolution?
MEASure:SPECTrum:VOLTage:RESolution <RESOLUTION>	MEASure:SPECTrum:VOLTage:RESolution?
MEASure:SPECTrum:VLL:RESolution <RESOLUTION>	MEASure:SPECTrum:VLL:RESolution?
MEASure:SPECTrum:CURRent:RESolution <RESOLUTION>	MEASure:SPECTrum:CURRent:RESolution?
MEASure:SPECTrum:PHASe:RESolution <RESOLUTION>	MEASure:SPECTrum:PHASe:RESolution?
MEASure:SPECTrum:THD:RESolution <RESOLUTION>	MEASure:SPECTrum:THD:RESolution?
MEASure:SPECTrum:OHD:RESolution <RESOLUTION>	MEASure:SPECTrum:OHD:RESolution?
MEASure:SPECTrum:EHD:RESolution <RESOLUTION>	MEASure:SPECTrum:EHD:RESolution?
MEASure:KWHour:RESolution <RESOLUTION>	MEASure:KWHour:RESolution?
FETCH[:WAVEform]:VOLTage:RESolution <RESOLUTION>	FETCH[:WAVEform]:VOLTage:RESolution?
FETCH[:WAVEform]:VLL:RESolution <RESOLUTION>	FETCH[:WAVEform]:VLL:RESolution?
FETCH[:WAVEform]:CURRent:RESolution <RESOLUTION>	FETCH[:WAVEform]:CURRent:RESolution?

8.5 Output Control Commands

The output command subsystem is used to control the output state of the power source. The following measurement commands are supported.

Command Syntax	OUTPut:FAST
Description	Enable or disable fast energy savings startup mode (STANDBY mode) when output is closed. This mode does not completely shut down all inverters for energy savings while the output is off. This allows near immediate application of output to the load when the output command is received. When disabled, there is delay of 2.2 seconds to allow all power stages to start up and settle in.
Parameters	< 0 OFF 1 ON >
Parameter Format	
Example	OUTP:FAST ON
Query Format	OUTPut:FAST?
Returned Data Format	
Query Example	OUTP:FAST?
	1

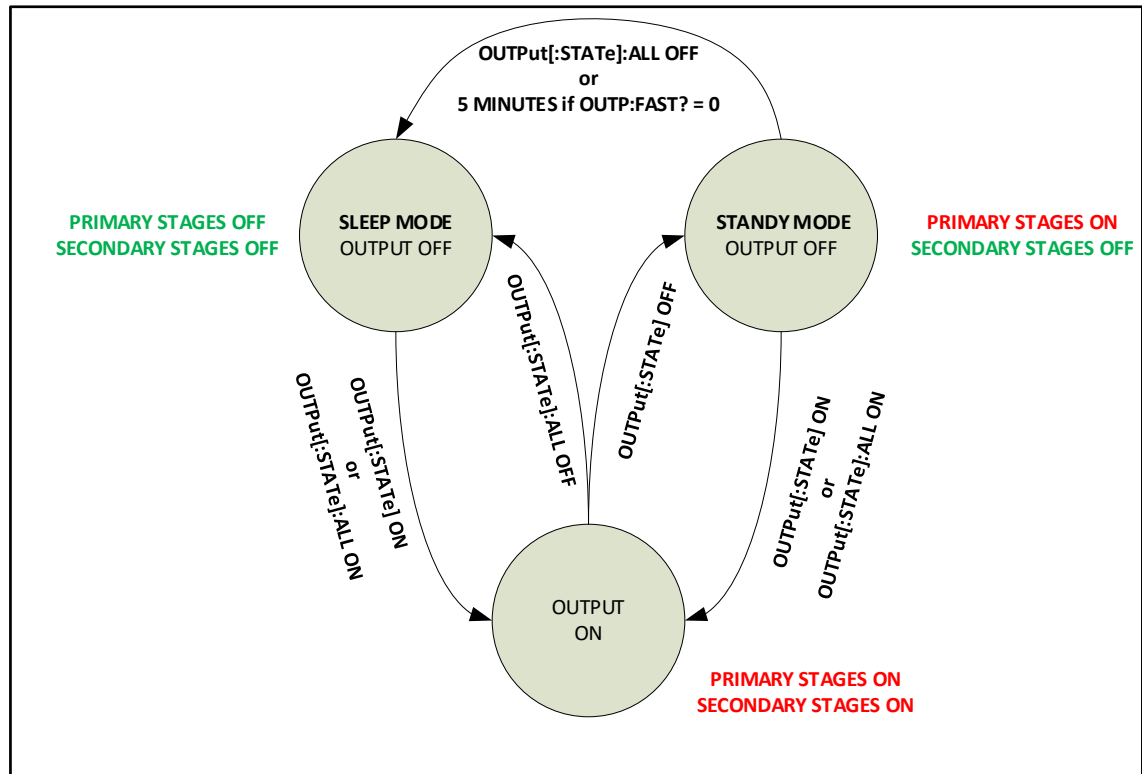

Figure 8-1: Energy Saving Modes and Output Commands State Diagram

Command Syntax Description	<p>OUTPut[:STATe]</p> <p>Enables or Disables power output. When enabled, all output relays are closed. When disabled, all output relays are open. The time it takes for the output to turn on is determined by the status of the OUTP:FAST setting.</p> <p>If the power source is in sleep mode (all power stages are off), it will take about 2.2 seconds before the output relays are closed. This is required to let all stages settle. If the power source is in standby mode, it will only take 200 msec to close the output relay as only the second (inverter) stage needs to settle.</p> <p>Note: Sending the OUTP OFF command will only cause the second stage to be turned off. The primary stages remain on and thus the AC source will be in standby mode. If OUTP:FAST = 0, the primary stages will turn off after 5 minutes of non-use and the AC source will enter sleep mode.</p> <p>Refer to section 6.2.2, “Energy Savings Modes” for more details.</p>
Parameters Parameter Format Example Query Format Returned Data Format Query Example	<p>< 0 OFF 1 ON ></p> <p></p> <p>OUTP ON</p> <p>OUTPut[:STATe]?</p> <p></p> <p>OUTP?</p> <p>1</p>
Command Syntax Description	<p>OUTPut[:STATe]:ALL</p> <p>This command enables or disables the output and is similar to the OUTPut[:STATe] command but always turns off all power stages, regardless of the energy savings mode set with the OUTP:FAST command. Thus, the OUTP:ALL OFF command will turn off all power stages and put the AC source in sleep mode.</p> <p>Note: The OUTP:ALL ON command has the same effect as the OUTP ON command.</p>
Parameters Parameter Format Example	<p>< 0 OFF 1 ON ></p> <p></p> <p>OUTP:ALL OFF</p>

Command Syntax Description OUTPut:AUTO = ON OUTPut:AUTO = OFF Parameters Parameter Format Example Query Format Returned Data Format Query Example	OUTPut[:STATe]:AUTO This commands determines the state of the OUTPUT when the power source is turned on (powered on). The output will be enabled at power on IF it was ON at the time the front panel circuit breaker of the unit was switched off. Thus, the output state will revert to the last state before power-off. This command in combination with the “[SOURce:]INITial” command allows the unattended resumption of a test station after a power failure. Note: This condition is potentially hazardous and should be used with caution. The output will always come up in the OFF state. < 0 OFF 1 ON > OUTP:AUTO ON OUTPut[:STATe]:AUTO? OUTP:AUTO? 1
Command Syntax Description Parameters Parameter Format Example Query Format Returned Data Format Query Example	OUTPut:DISABLEPHase This command sets the disable phase angle. This is the phase angle on phase A at which the power source output will be disabled. Available range is 0 ~ 360. Also allows a negative number that indicates a RANDOM phase angle/ Note: Available in units with Firmware revision 1.6.6 or higher. Refer also to the OUTPut:ZEROprogram command. 0.0 ~ 360.0 or negative number <nr2> OUTPDISABLEPH 90.0 OUTPDISABLEPH -1 OUTPut:DISABLEPHase? <nr2> OUTP:DISABLEPH? 90.000

Query Syntax	OUTPut:DISABLEPHase:MINimum OUTPut:DISABLEPHase:MAXimum OUTPut:DISABLEPHase:DEFault
Description	These query commands return minimum, maximum and default Output Disable Phase values respectively. Available range is -0.01 (Random) through 360.0. Note: Available in units with Firmware revision 1.6.6 or higher.
Returned Data Format	<nr2>
Query Example	OUTP:DISABLEPH:MIN? -0.010 OUTP:DISABLEPH:MAX? 360.000 OUTP:DISABLEPH:DEF? 0.000
Command Syntax Description	OUTPut:ZEROprogram This command sets the programmed output voltage to zero before opening the output relay when the OUTP OFF 0 command is sent. This feature is disabled by default but can be enabled by sending OUTP:ZERO ON 1. In this mode, the output of the power source goes to a low impedance state for 100 msec before disconnecting the load (output relay open) unless RAMP and DELAY are changed. Note: Available in units with Firmware revision 1.6.6 or higher. Refer also to the OUTPut:DISABLEPHase command.
Parameters	< 0 OFF 1 ON >
Parameter Format	
Example	OUTP:ZERO 1
Query Format	OUTPut:ZEROprogram?
Returned Data Format	
Query Example	OUTP:ZERO? 1
Command Syntax Description	OUTPut:ZEROprogram:RAMP <nr1> This command sets the voltage ramp down to zero time before opening the output relay when the OUTP OFF 0 command is sent. See Figure for reference. Default value is 0 msec. This command is intended for uses with XFMR units but configurable for both couplings. XFMR and direct parameters are independent. For direct coupling delay is 100ms and ramp 0ms by default but can be changed to any value. The ramp allows the voltage to reduce slowly, useful for reducing the magnetization of the transformer so at the next turn on, there is no excessive peak current due to remaining magnetization.
Parameters	Time in msecs.
Parameter Format	<nr1>
Example	OUTP:ZERO:RAMP? 50

Query Format	OUTPut:ZEROprogram:RAMP?
Returned Data Format	<nr1>
Query Example	OUTP:ZERO:RAMP?
	50

Command Syntax Description	OUTPut:ZEROprogram:DWELL <nr1> This command sets the voltage dwell time before opening the output relay when the OUTP OFF 0 command is sent. See Figure for reference. Default value is 100 msec. Note: Available in units with Firmware revision 2.2.12 or higher.
Parameters	Time in msecs.
Parameter Format	<nr1>
Example	OUTP:ZERO:DWELL? 20
Query Format	OUTPut:ZEROprogram:DWELL?
Returned Data Format	<nr1>
Query Example	OUTP:ZERO:DWELL?
	20

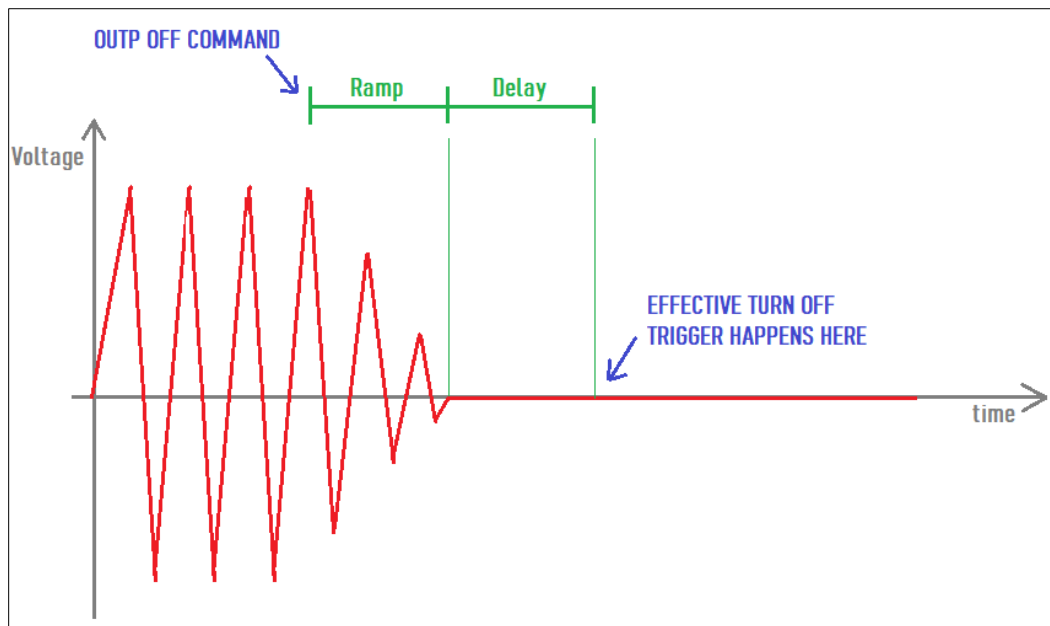

Figure 8-2: OUTP:ZERO Command Ramp and Dwell settings

8.6 Program Commands

Program commands allow management and programming of stored program segments for steady state and Transients. These commands are grouped by the following subsystems.

- Program Control Commands
- Execution Commands
- Transient Segment Commands
- Memory Management Commands

The Program commands are similar to those found on the Pacific Power UPC controllers used for other PPS AC power source models.

8.6.1 Program Control Commands

The following commands allow recall of stored programs and transient segments. Programs are selected and recalled using their memory location reference ranging from 1 through 99. Program location zero (0) is reserved for the Manual Mode setup. Optionally, a memory source may be specified. If none is provided, INTERNAL memory is used as a default.

Command Syntax	PROG ram:NAME [<nr1>,<cr>] [<cr>,<cr>] <cr>
Description	This command selects program <nr1> for execution deletion or copying.
Parameters	Option: PROGRAM, NUMBER [,<cr>} or [,<nr1>] - 0 through 99 Option: MEMORY [,<cr>} – Available are: INTERNAL RAM USB Parameter list define string <cr>,<cr>,<cr>,<cr>,<cr>
Parameter Format	<nr1> [,<cr>]
Example	PROG:NAME 4, USB
Query Format	PROG ram:NAME?
Description	The query format of this command returns the value of last program selected. Returned value range is 0 through 99.
Returned Data Format	<nr1>
Query Example	PROG:NAME? 4

Command Syntax Description	<p>PROG[:SELEcted]:DEFine [<nr1>] [<cr>] <cr></p> <p>This command programs all values stored in the selected program number. Both steady-state and transient segment parameter names and values may be sent. Program parameters are defined in the following sections.</p> <p>NOTE: Only commas may separate the values, NO Carriage Returns or Line Feeds may separate the values within a single command message.</p>
Parameters	<p>Option: PROGRAM, NUMBER [,<cr>} or [,<nr1>]</p> <p>Option: MEMORY [,<cr>] – Available are: INTERNAL RAM USB</p> <p>Parameter list define string <cr>,<cr>,<cr>,<cr></p> <p>Note 1: All the tags must be uppercase.</p> <p>Note 2:The order on the transient/step tags must be sequential.</p>
Steady State list Tags	<p>FORM,<n>, COUPLing,<s>, XFMRRATIO,<n.nn>, FREQUency,<n>, VOLTage,<n>, VOLTage1,<n>, VOLTage2,<n>, VOLTage3,<n>, CURRent:LIMit,<n>, CURRent:PROTect:LEVel,<n> CURRent:PROTect:TOUT,<n> PHASe2,<n>, PHASe3,<n>, WAVEFORM,<n>, WAVEFORM1,<n>, WAVEFORM2,<n>, WAVEFORM3,<n>, EVENTS,<n>, AUTORMS,<n> NSEGS, <n></p> <p>see Convention #13.</p> <p>see Convention #13.</p>
Optional Transient SEGment list Tags	<p>SEGment,<n>, FSEG,<n>, VSEG,<n>, VSEG1,<n>, VSEG2,<n>, VSEG3,<n>, VSEGDC, <n> VSEGDC1, <n> VSEGDC2, <n> VSEGDC3, <n> PSEG1, <n> PSEG2, <n> PSEG3, <n> WFSEG,<n> WFSEG1,<n>, WFSEG2,<n>, WFSEG3,<n>, TSEG,<n>, LAST</p> <p>Multiple segments per Program Message may be sent, see Convention 17.</p> <p>AC Voltage, see Convention #13.</p> <p>DC Voltage, see Convention #13.</p> <p>Cmd available for FW 3.6.x or higher only</p> <p>see Convention #13.</p> <p>Sent only if this is the LAST segment.</p>

Optional Transient STEP list Tags	<p>A STEP is composed of two segments, a ramp segment and at dwell segment. Multiple STEPs per Program Message may be sent, see Convention 17.</p> <p>FSTEP,<n></p> <p>VSTEP,<n> see Convention #13.</p> <p>VSTEP1,<n></p> <p>VSTEP2,<n></p> <p>VSTEP3,<n></p> <p>VSTEPDC,<n> see Convention #13.</p> <p>VSTEPDC1,<n></p> <p>VSTEPDC2,<n></p> <p>VSTEPDC3,<n></p> <p>PSETEP1, <n></p> <p>PSTEP2, <n></p> <p>PSTEP3, <n></p> <p>WFSEG,<n> see Convention #13.</p> <p>WFSEG1,<n></p> <p>WFSEG2,<n></p> <p>WFSEG3,<n></p> <p>RTSTEP,<n> Ramp time</p> <p>DTSTEP,<n> Dwell time</p> <p>LAST Sent only if this is the LAST segment.</p>
Parameter Format	<cr>,<cr>,<cr>,<cr>
Query Format	PROG[:SElected]:DEFine? [<nr1>] [<cr>]
Description	The Query format returns steady-state values of selected program and segment values of most recently selected segment or multiple segments if specified by a previous NSEGS parameter. "LAST" is returned with segment data if the segment is the last segment in the program.
Returned Data Format	Refer to parameter lists shown above
Query Example	PROG:DEF? 6 <nr1>, <cr>,<cr>,<cr>

Segment Example Program Strings:

TRANSIENT EXECUTION

RUN **STOP** **STEP** **RESTART**

STATE: **STOPPED**

PROGRESS: 0%

REPEAT TIMES COUNTER: 0

CONFIGURATION: **SETTINGS**

RUN FROM SEGMENT #: 1

RUN TO SEGMENT #: 2

REPEAT TIMES: Infinite

APPLY CANCEL

TRANSIENT TABLE

MODE: **STEP** **SEGMENT** EDIT MODE: **CYCLE BASED** **TIME BASED**

#	TIME [ms]	FREQ [Hz]	V _{AC} [V _{RMS}] A/B/C	V _{DC} [V] A/B/C	Waveform [#] A/B/C	Phase [Deg] A/B/C	
1	100.0	60.00	0.00	0.00	1	0.00/120.00/240.00	+ X
2	100.0	60.00	0.00	0.00	1	0.00/120.00/240.00	+ X

APPLY CANCEL

PROGram:DEFine

```
FORM,3,COUPL,DIRECT,VOLT:MODE,2,CONFIG,0,RANG,0,FREQ,60.000,VOLT1,0.000,VOLT2,0.000,VOLT3,0.000,VOLT:ALC:STAT,1,CURR:OV,0,CURR:LIM1,130.000,CURR:LIM2,130.000,CURR:LIM3,130.000,IPROT:STAT,0,CURR:PROT:LEV,130.000,IPEAK:LIM,360.000,PHAS1,0.000,PHAS2,120.000,PHAS3,240.000,WAVEFORM1,1,WAVEFORM2,1,WAVEFORM3,1,VOLT:DC1,0.000,VOLT:DC2,0.000,VOLT:DC3,0.000,POW:LIM1,17.2500,POW:LIM2,17.2500,POW:LIM3,17.2500,KVA:LIM1,17.2500,KVA:LIM2,17.2500,KVA:LIM3,17.2500,PPROT:STAT,0,POW:PROT:LEV,17.2500,KVA:PROT:LEV,17.2500,PROT:TDELAY,5,FREQ:SLEW,5.000,VOLT:SLEW,10.000,VOLT:DC:SLEW,10.000,UPDATEPH,0.000,RAMP,0.0002,VPEAK:MARG,100.000,EVENTS,0,AUTORMS,1,SEG,1,FSEG,60.00,VSEG1,0.00,VSEG2,0.00,VSEG3,0.00,VDCSEG1,0.00,VDCSEG2,0.00,VDCSEG3,0.00,PSEG2,120.00,PSEG3,240.00,WFSEG1,1,WFSEG2,1,WFSEG3,1,TSEG,0.1000,SEG,2,FSEG,60.00,VSEG1,0.00,VSEG2,0.00,VSEG3,0.00,VDCSEG1,0.00,VDCSEG2,0.00,VDCSEG3,0.00,PSEG2,120.00,PSEG3,240.00,WFSEG1,1,WFSEG2,1,WFSEG3,1,TSEG,0.1000,LAST (Note I removed NSEGS,2 PSEG1,0.00)
```

PROGram:DEFine:ALL?

```
FORM,3,COUPL,DIRECT,VOLT:MODE,2,CONFIG,0,RANG,0,FREQ,60.000,VOLT1,0.000,VOLT2,0.000,VOLT3,0.000,VOLT:ALC:STAT,1,CURR:OV,0,CURR:LIM1,130.000,CURR:LIM2,130.000,CURR:LIM3,130.000,IPROT:STAT,0,CURR:PROT:LEV,130.000,IPEAK:LIM,360.000,PHAS1,0.000,PHAS2,120.000,PHAS3,240.000,WAVEFORM1,1,WAVEFORM2,1,WAVEFORM3,1,VOLT:DC1,0.000,VOLT:DC2,0.000,VOLT:DC3,0.000,POW:LIM1,17.2500,POW:LIM2,17.2500,POW:LIM3,17.2500,KVA:LIM1,17.2500,KVA:LIM2,17.2500,KVA:LIM3,17.2500,PPROT:STAT,0,POW:PROT:LEV,17.2500,KVA:PROT:LEV,17.2500,PROT:TDELAY,5,FREQ:SLEW,5.000,VOLT:SLEW,10.000,VOLT:DC:SLEW,10.000,UPDATEPH,0.000,RAMP,0.0002,VPEAK:MARG,100.000,EVENTS,0,AUTORMS,1,NSEGS,2,SEG,1,FSEG,60.00,VSEG1,0.00,VSEG2,0.00,VSEG3,0.00,VDCSEG1,0.00,VDCSEG2,0.00,VDCSEG3,0.00,PSEG1,0.00,PSEG2,120.00,PSEG3,240.00,WFSEG1,1,WFSEG2,1,WFSEG3,1,TSEG,0.1000,SEG,2,FSEG,60.00,VSEG1,0.00,VSEG2,0.00,VSEG3,0.00,VDCSEG1,0.00,VDCSEG2,0.00,VDCSEG3,0.00,PSEG1,0.00,PSEG2,120.00,PSEG3,240.00,WFSEG1,1,WFSEG2,1,WFSEG3,1,TSEG,0.1000,LAST
```

Step Example Program Strings:

TRANSIENT EXECUTION

RUN STOP STEP RESTART RUN FROM STEP # 1 + -

STATE STOPPED RUN TO STEP # 1 + -

PROGRESS 0% REPEAT TIMES Infinite + -

REPEAT TIMES COUNTER 0

CONFIGURATION SETTINGS

APPLY CANCEL

TRANSIENT TABLE

MODE STEP SEGMENT EDIT MODE CYCLE BASED TIME BASED

#	RAMP [ms]	DWELL [ms]	FREQ [Hz]	V _{AC} [V _{RMS}] A/B/C	V _{DC} [V] A/B/C	Waveform [#] A/B/C	Phase [Deg] A/B/C
> 1	100.0	100.0	60.00	0.00	0.00	1	0.00/120.00/240.00

APPLY CANCEL + ADD ROW - DELETE ROW CLEAR

PROGram:DEFine

```
FORM,3,COUPL,DIRECT,VOLT:MODE,2,CONFIG,0,RANG,0,FREQ,60.000,VOLT1,0.000,VOLT2,0.000,VOLT3,0.000,VOLT:ALC:STAT,1,CURR:OV,0,CURR:LIM1,130.000,CURR:LIM2,130.000,CURR:LIM3,130.000,IPROT:STAT,0,CURR:PROT:LEV,130.000,IPEAK:LIM,360.000,PHAS1,0.000,PHAS2,120.000,PHAS3,240.000,WAVEFORM1,1,WAVEFORM2,1,WAVEFORM3,1,VOLT:DC1,0.000,VOLT:DC2,0.000,VOLT:DC3,0.000,POW:LIM1,17.2500,POW:LIM2,17.2500,POW:LIM3,17.2500,KVA:LIM1,17.2500,KVA:LIM2,17.2500,KVA:LIM3,17.2500,PPROT:STAT,0,POW:PROT:LEV,17.2500,KVA:PROT:LEV,17.2500,PROT:TDELAY,5,FREQ:SLEW,5.000,VOLT:SLEW,10.000,VOLT:DC:SLEW,10.000,UPDATEPH,0.000,RAMP,0.0002,VPEAK:MARG,100.000,EVENTS,0,AUTORMS,1,STEP,1,FSTEP,60.00,VSTEP1,0.00,VSTEP2,0.00,VSTEP3,0.00,VDCSTEP1,0.00,VDCSTEP2,0.00,VDCSTEP3,0.00,PSTEP2,120.00,PSTEP3,240.00,WFSTEP1,1,WFSTEP2,1,WFSTEP3,1,RTSTEP,0.1000,DTSTEP,0.1000,LAST
```

Note: NSTEPS,1, PSTEP1,0.00 not included in program command.

PROGram:DEFine:ALL?

```
FORM,3,COUPL,DIRECT,VOLT:MODE,2,CONFIG,0,RANG,0,FREQ,60.000,VOLT1,0.000,VOLT2,0.000,VOLT3,0.000,VOLT:ALC:STAT,1,CURR:OV,0,CURR:LIM1,130.000,CURR:LIM2,130.000,CURR:LIM3,130.000,IPROT:STAT,0,CURR:PROT:LEV,130.000,IPEAK:LIM,360.000,PHAS1,0.000,PHAS2,120.000,PHAS3,240.000,WAVEFORM1,1,WAVEFORM2,1,WAVEFORM3,1,VOLT:DC1,0.000,VOLT:DC2,0.000,VOLT:DC3,0.000,POW:LIM1,17.2500,POW:LIM2,17.2500,POW:LIM3,17.2500,KVA:LIM1,17.2500,KVA:LIM2,17.2500,KVA:LIM3,17.2500,PPROT:STAT,0,POW:PROT:LEV,17.2500,KVA:PROT:LEV,17.2500,PROT:TDELAY,5,FREQ:SLEW,5.000,VOLT:SLEW,10.000,VOLT:DC:SLEW,10.000,UPDATEPH,0.000,RAMP,0.0002,VPEAK:MARG,100.000,EVENTS,0,AUTORMS,1,NSTEPS,1,STEP,1,FSTEP,60.00,VSTEP1,0.00,VSTEP2,0.00,VSTEP3,0.00,VDCSTEP1,0.00,VDCSTEP2,0.00,VDCSTEP3,0.00,PSTEP1,0.00,PSTEP2,120.00,PSTEP3,240.00,WFSTEP1,1,WFSTEP2,1,WFSTEP3,1,RTSTEP,0.1000,DTSTEP,0.1000,LAST
```

8.6.1.1 Steady State Output Parameter List Table

The following table details the available parameters for the steady state program definitions.

Parameter	Description
FORM,<n>	sets Output Power Form of selected program n = <1>Single Φ , <2>Split Φ , or <3>Three Φ
COUPLing,<s>	sets Output coupling of selected program s = <DIRECT> <0> or <XFMR> <1>
XFMRRatio,<n.nn>	sets Output XFMR ratio (n.nn:1) of selected program n.nn = <0.0100> to <5.1111>
FREQuency,<n>	sets Output Frequency of selected program n = <:SOUR:FREQ:LIM:MIN> to <:SOUR:FREQ:LIM:MAX> Hz
VOLTage,<n>	sets Output VOLTAGE Φ A,B,C of selected program n = <0> to <300 x XFMRRatio> Volts
VOLTage1,<n>	sets Output VOLTAGE Φ A of selected program n = <0> to <300 x XFMRRatio> Volts
VOLTage2,<n>	sets Output VOLTAGE Φ B of selected program n = <0> to <300 x XFMRRatio> Volts
VOLTage3,<n>	sets Output VOLTAGE Φ C of selected program n = <0> to <300 x XFMRRatio> Volts
CURRent:LIMit,<n>	sets Output Current Limit of selected program n = <0> to <AMPS meter range> Amps
CURRent:PROTect:LEVel,<n>	sets Output Current level that triggers Current Protect mode n = <0> to <AMPS meter range> Amps
CURRent:PROTect:TOUT,<n>	sets time that the Output Current must exceed the Current Protect level before Current Protect disables the power source output. n = <1> to <65535>, 1 = 100mSec.
PHASe2,<n>	sets Output Phase Angle B of selected program n = <0> to <359> degrees
PHASe3,<n>	sets Output Phase Angle C of selected program n = <0> to <359> degrees
WAVEFORM,<n>	sets Output Waveform Φ A, Φ B, Φ C of selected program n = <1> to <16>
WAVEFORM1,<n>	sets Output Waveform Φ A of selected program n = <1> to <16>
WAVEFORM2,<n>	sets Output Waveform Φ B of selected program n = <1> to <16>
WAVEFORM3,<n>	sets Output Waveform Φ C of selected program n = <1> to <16>
EVENTS,<n>	sets number of times to repeat the transient portion of the selected program when the Transient is executed n = 0-65535. A value of 0 specifies continuous operation
AUTORMS,<n>	program Transient Waveform Auto RMS mode (4.5.2) n = 0, use program steady-state waveform RMS factor n = 1, calculate RMS factor based on transient waveform
NSEGS,<n>	Command: Specifies the number of Transient segments (all parameters) to return in a subsequent :PROG:DEFine? query. If NSEGS is not specified, 1 segment is returned by :PROG:DEFine? EXAMPLE: :PROG:DEF SEG,3,NSEGS,4;PROG:DEF? will return 4 transient segments, starting with Segment 3. NOTE: The value will revert back to 1 after each query.

Parameter	Description
	Query: The NSEGS parameter of a :PROG:DEF? query returns total number of Transient segments defined in the selected program

8.6.1.2 Transient Segment Output Parameter List Table

The following table details the available parameters for the transient segment program definitions.

Parameters	Description
SEGment,<n>	Transient segment n of the selected program to be edited. Also the starting segment when querying multiple segments (see NSEGS) n = <1> to <100>
FSEG,<n>	sets objective Frequency of selected segment n = <:SOUR:FREQ:LIM:MIN> to <:SOUR:FREQ:LIM:MAX> Hz
VSEG,<n>	sets objective voltage ΦA , ΦB , ΦC of selected segment n = <0> to <300 x XFMRRTATIO> Volts
VSEG1,<n>	sets objective voltage ΦA of selected segment n = <0> to <300 x XFMRRTATIO> Volts
VSEG2,<n>	sets objective voltage ΦB of selected segment n = <0> to <300 x XFMRRTATIO> Volts
VSEG3,<n>	sets objective voltage ΦC of selected segment n = <0> to <300 x XFMRRTATIO> Volts
WFSEG,<n>	sets Waveform ΦA , ΦB , ΦC of selected segment n = <1> to <16>
WFSEG1,<n>	sets Waveform ΦA of selected segment n = <1> to <16>
WFSEG2,<n>	sets Waveform ΦB of selected segment n = <1> to <16>
WFSEG3,<n>	sets Waveform ΦC of selected segment n = <1> to <16>
TSEG,<n>	sets execution time (to reach objective Voltage and Frequency) of selected segment n = <0> or <0.0002> to <300> seconds. Setting n to a negative value such as -5 selects cycle-based transient operation, i.e., each segment time is equal to the period of 5 cycles (1 cycle = 1/FREQ secs)
LAST	sets selected segment to be the last segment of selected transient

Command Syntax	PROG:EXECuted:DEFine# <cr>
Description	This command programs all values stored in the selected program number. Both steady-state and transient segment parameter names and values may be sent. Program parameters are defined in the following sections. The phase selection (#) allows saving in FORM2 and FORM3 as phases can be programmed for individual settings. NOTE: Only commas may separate the values, NO Carriage Returns or Line Feeds may separate the values within a single command message.
Parameters	Refer to PROG:SElected:DEFine command
Parameter Format	<cr>,<cr>,...,<cr>,<cr>
Example	
Query Format	PROG:EXECuted:DEFine#?
Returned Data Format	<cr>,<cr>,...,<cr>,<cr> The response separates each output transient with a semicolon (;)
Query Example	PROG:EXEC:DEF? -> parameter list grouped by

Transient Format Example:

```

<TRANSIENT>
  <OUTPUT_A>
    <EVENTS>0</EVENTS>
    <AUTORMS>1</AUTORMS>
    <STEP NUMBER=" 1 ">
      <FSTEP>60.00</FSTEP>
      <ACSTEP>10.00</ACSTEP>
      <DCSTEP>0.00</DCSTEP>
      <PSTEP>0.00</PSTEP>
      <WFSTEP>1</WFSTEP>
      <RTSTEP>0.1000</RTSTEP>
      <DTSTEP>2.0000</DTSTEP>
    </STEP>
    <STEP NUMBER=" 2 ">
      <FSTEP>60.00</FSTEP>
      <ACSTEP>15.00</ACSTEP>
      <DCSTEP>0.00</DCSTEP>
      <PSTEP>0.00</PSTEP>
      <WFSTEP>1</WFSTEP>
      <RTSTEP>0.1000</RTSTEP>
      <DTSTEP>2.0000</DTSTEP>
    </STEP>
  </OUTPUT_A>
  <OUTPUT_B>
    ---
    ---
  </OUTPUT_B>
  <OUTPUT_C>
    ---
    ---
  </OUTPUT_C>
</TRANSIENT>

```

Query Format	PROGram[:SElected]:DEFine:ALL?
Description	This query returns the parameter list for the selected program number or name.
Parameters	Option: PROGRAM, NUMBER [,<cr>] or [,<nr1>] Option: MEMORY [,<cr>]– Available are: INTERNAL RAM USB Parameter list define string <cr>,<cr>,<cr>,<cr>
Query Example	PROG:DEF:ALL? -> parameter list
Query Format	PROGram:EXECuted:DEFine:ALL?
Description	This query returns the parameter list for the executing program number or name.
Parameters	Option: PROGRAM, NUMBER [,<cr>] or [,<nr1>] Option: MEMORY [,<cr>] Parameter list define string <cr>,<cr>,<cr>,<cr>,<cr>
Query Example	PROG:EXEC:DEF:ALL? 3 -> parameter list
Command Syntax	PROGram[:SElected]:INFORmation <cr> [,<nr1>] [,<cr>]
Description	This command assigns program information data to the selected program.
Parameters	Information string <cr> Option: PROGRAM NUMBER [,<nr1>] Option: MEMORY [,<cr>]– Available are: INTERNAL RAM USB
Parameter Format	<cr> [,<nr1>] [,<cr>]
Example	PROG:INFO 3, INTERNAL, SAMPLE TEST
Query Format	PROGram[:SElected]:INFORmation? [<nr1>] [,<cr>]
Returned Data Format	<cr>
Query Example	PROG:INFO? 2, USB -> Program info string
Command Syntax	PROGram:EXECuted:INFORmation <cr> [,<nr1>] [,<cr>]
Description	This command assigns program information data to the executing program.
Parameters	Information string <cr> Option: PROGRAM NUMBER [,<nr1>] Option: MEMORY [,<cr>]– Available are: INTERNAL RAM USB
Parameter Format	<cr> [,<nr1>] [,<cr>]
Example	PROG:EXEC:INFO 3, INTERNAL, SAMPLE TEST
Query Format	PROGram:EXECuted:INFORmation? [<nr1>] [,<cr>]
Returned Data Format	<cr>
Query Example	PROG:EXEC:INFO? 2, USB -> Program info string

<p>Command Syntax Description</p> <p>Parameters</p> <p>Parameter Format Example Query Format Returned Data Format Query Example</p>	<p>PROGram[:SElected]:ALIAS <cr> [,<nr1>] [,<cr>]</p> <p>This command assigns a user provided alias string name to the selected program. Program number and memory type are optional parameters.</p> <p>Alias String <cr> Option: PROGRAM NUMBER [,<nr1>] Option: MEMORY [,<cr>]– Available are: INTERNAL RAM USB</p> <p><cr> [,<nr1>] [,<cr>]</p> <p>PROG:ALIAS TEST1</p> <p>PROGram[:SElected]:ALIAS? [,<nr1>] [,<cr>]</p> <p><cr></p> <p>PROG:ALIAS? TEST1</p>
<p>Command Syntax Description</p> <p>Parameters</p> <p>Parameter Format Example Query Format Returned Data Format Query Example</p>	<p>PROGram:EXECuted:ALIAS <cr> [,<nr1>] [,<cr>]</p> <p>This command assigns a user provided alias string name to the executing program. Program number and memory type are optional parameters.</p> <p>Alias String <cr> Option: PROGRAM NUMBER [,<nr1>] Option: MEMORY [,<cr>]– Available are: INTERNAL RAM USB</p> <p><cr> [,<nr1>] [,<cr>]</p> <p>PROG:EXEC:ALIAS TEST2</p> <p>PROGram:EXECuted:ALIAS? [,<nr1>] [,<cr>]</p> <p><cr></p> <p>PROG:EXEC:ALIAS? TEST2</p>
<p>Query Format Description</p> <p>Parameters</p> <p>Returned Data Format Query Example</p>	<p>PROGram[:SElected]:SST? [,<nr1>] [,<cr>]</p> <p>This command returns the Steady State Table settings of the selected program only. The transient table data is not returned.</p> <p>Option: PROGRAM NUMBER [,<nr1>] Option: MEMORY [,<cr>]– Available are: INTERNAL RAM USB</p> <p><cr></p> <p>PROG:SST? 2, USB -> steady state table program data</p>
<p>Query Format Description</p> <p>Parameters</p> <p>Returned Data Format Query Example</p>	<p>PROGram:EXECuted:SST? [,<nr1>] [,<cr>]</p> <p>This command returns the Steady State Table settings of the executing program only. The transient table data is not returned.</p> <p>Option: PROGRAM NUMBER [,<nr1>] Option: MEMORY [,<cr>]– Available are: INTERNAL RAM USB</p> <p><cr></p> <p>PROG:EXEC:SST? -> steady state table program data</p>

Query Format Description	<p>PROGram:TT? [<nr1>][,<nr1>] [<cr>]</p> <p>This command returns the Transient Table settings of the program number specified. The format in which the data is returned can be specified with the first parameter.</p> <p>If no program number is passed as a parameter, the selected program data is returned. See PROG:NAME for the selected program. The steady state table data is not returned.</p> <p>If no memory type is specified, the transient table stored in the selected memory type is returned. See PROG:MEMORY for the selected memory type.</p>
Parameters	<p>Option: STYLE [<nr1>]</p> <p>0 = Human readable Style A (default if omitted)</p> <p>1 = Human readable Style B</p> <p>2 = Binary Data Format. Can be more useful to search for differences between programs.</p> <p>Option: PROGRAM NUMBER [<nr1>]</p> <p>Option: MEMORY [<cr>]– Available are: INTERNAL RAM USB</p>
Returned Data Format Query Example	<p><cr></p> <p>PROG:TT? 1,2</p> <p>-> transient table program data</p> <p>Formats for transient table shown below are:</p> <p>Style A: 3,1,1,100.0,100.0,60.000,0.000,1.000 2.000 3.000,1,0.0 120.0 240.0S</p> <p>Style B: 3,1,1,100.0,100.0,60.000,0.000,0.000,0.000,0.000,1.000,1.000,2.000,3.000,1,1,1,1,0.0,120.0,240.0</p> <p>Binary: 0000704200000000000000000000000000000000000000803F00000040000040400 000F0420000704301010100F401000000007042000000000000000000 0000000000803F00000040000040400000F0420000704301010100F40 10000</p>
Query Format Description	<p>PROGram[:SElected]:TT? [<nr1>] [<cr>]</p> <p>This command returns the Transient Table settings of the selected program only. The steady state table data is not returned.</p>
Parameters	<p>Option: STYLE [<nr1>]</p> <p>0 = Human readable Style A (default if omitted)</p> <p>1 = Human readable Style B</p> <p>2 = Binary Data Format. Can be more useful to search for differences between programs.</p> <p>See PROGram:TT? Command for formats</p> <p>Option: PROGRAM NUMBER [<nr1>]</p> <p>Option: MEMORY [<cr>]– Available are: INTERNAL RAM USB</p>
Returned Data Format Query Example	<p><cr></p> <p>PROG:TT? 1</p> <p>-> transient table program data</p>

<p>Query Format Description</p> <p>Parameters</p> <p>Returned Data Format Query Example</p>	<p>PROG:EXECuted:TT? [,<nr1>] [,<cr>]</p> <p>This command returns the Transient Table settings of the executing program only. The steady state table data is not returned.</p> <p>Option: STYLE [,<nr1>] 0 = Human readable Style A (default if omitted) 1 = Human readable Style B 2 = Binary Data Format. Can be more useful to search for differences between programs.</p> <p>See PROG:TT? Command for formats</p> <p>Option: PROGRAM NUMBER [,<nr1>] Option: MEMORY [,<cr>]– Available are: INTERNAL RAM USB <cr></p> <p>PROG:EXEC:TT? 2 -> transient table program data</p>
<p>Query Format Description</p> <p>Parameters</p> <p>Returned Data Format Query Example</p>	<p>PROG[:SElected]:CHECK? [,<nr1>] [,<cr>]</p> <p>This command performs a check on the selected program steady state and transient tables looking for the following conditions:</p> <ul style="list-style-type: none"> • Hardware Limit violations • User Limit violations • Saturation limits. <p>If no violations are present, this command returns OK and the program can be executed without generating any errors. If the selected program cannot be run due to one or more issues with its content, one or more errors detailing the issues will be returned. For example, if the upper voltage user limit is set to 100V and the program contains a setting of 300V, a “Cannot load program, Run PROGRAM:CHECK?” error will be generated when attempting to execute this program. When sending the PROGRAM:CHECK? Query, the response will be “VOLT1 AC voltage set point cannot change due to user limit”.</p> <p>Option: PROGRAM NUMBER [,<nr1>] Option: MEMORY [,<cr>]– Available are: INTERNAL RAM USB <cr></p> <p>PROG:CHECK? VOLT1 AC voltage set point cannot change due to user limit</p>
<p>Query Format Description</p> <p>Parameters</p> <p>Returned Data Format Query Example</p>	<p>PROG:EXECuted:CHECK? [,<nr1>] [,<cr>]</p> <p>This command serves the same purpose as the PROG:CHECK? Command but applies to a program that is executing.</p> <p>Option: PROGRAM NUMBER [,<nr1>] Option: MEMORY [,<cr>]– Available are: INTERNAL RAM USB <cr></p> <p>PROG:EXEC:CHECK? VOLT1 AC voltage set point cannot change due to user limit</p>

<p>Command Syntax Description</p> <p>Parameters Parameter Format Example</p>	<p>PROGram[:SElected]:DELeTe</p> <p>This command deletes the selected program. Attempting to DELeTe an EXECuting Program will result in an Error.</p> <p>Program number</p> <p><nr1></p> <p>PROG:DEL 9</p>
<p>Query Format Description</p> <p>Parameters</p> <p>Returned Data Format Decoding</p> <p>Query Example Example</p>	<p>PROGram[:SElected]:CHANges? <nr1>, <cr></p> <p>This command compares the program that is executing with another program stored in the memory type and location passed as parameters. The results of the comparison is returned as a decimal number ranging from 0 to 15 representing a four bit binary value. This result can be decoded as shown below.</p> <p>Option: PROGRAM NUMBER [,<nr1>]</p> <p>Option: MEMORY [,<cr>]– Available are: INTERNAL RAM USB</p> <p><nr>1</p> <p>Bit 0: If set to 1, there are differences in the steady state table (SST)</p> <p>Bit 1: If set to 1, there are differences in the transient table (TT)</p> <p>Bit 2: If set to 1, there are differences in the ALIAS of the program</p> <p>Bit 3: If set to 1, there are differences in INfOrmation of the program</p> <p>PROG:CHAN?</p> <p>16</p> <p>If the query returns zero (0), the program executing is identical to the stored program referenced.</p> <p>If the command returns three (3), the program executing has differences with the referenced program in both the steady state table and the transient table.</p>
<p>Command Syntax Description</p> <p>Parameters</p> <p>Parameter Format Example</p>	<p>PROGram[:SElected]:COpy <nr1> [,<cr>]</p> <p>This command copies the selected program as previously specified by the PROG:NAME <nr1> command to destination program number.</p> <p>NOTE: The destination Program specified cannot be currently executing.</p> <p>DESTINATION PROGRAM NUMBER <nr1></p> <p>Option: MEMORY [,<cr>]– Available are: INTERNAL RAM USB</p> <p><nr1>, [,<cr>.]</p> <p>PROG:COpy 2, USB</p>
<p>Command Syntax Description</p> <p>Parameters</p> <p>Parameter Format Example</p>	<p>PROGram:EXECuted:COpy <nr1> [,<cr>]</p> <p>This command copies the executed program to destination program number.</p> <p>DESTINATION PROGRAM NUMBER <nr1></p> <p>Option: MEMORY [,<cr>]– Available are: INTERNAL RAM USB</p> <p><nr1>, [,<cr>.]</p> <p>PROG:EXEC:COpy 2, USB</p>

8.6.2 Execution Commands

The following commands may be used to control stored program executions.

Command Syntax	PROG ram[:SElected]:EXECute [<nr1> [,<cr>]
Description	This command executes the selected program (default) or the program number passed as the first parameter.
Parameters	Option: PROGRAM NUMBER [,<nr1>] Option: MEMORY [,<cr>]– Available are: INTERNAL RAM USB
Parameter Format	[<nr1> [,<cr>]
Example	PROG:EXEC 2
Query Format	PROG ram[:SElected]:EXECute ?
Description	The query format returns the number of the program that is in effect.
Parameter Format	<nr1>
Example	PROG:EXEC? 23
Command Syntax	PROG ram:EXECute:TRANS [<nr1> [,<cr>]
Description	This command executes the selected program’s (default) transient table or the program number passed as the first parameter.
Parameters	Option: PROGRAM NUMBER [,<nr1>] Option: MEMORY [,<cr>]– Available are: INTERNAL RAM USB
Parameter Format	[<nr1> [,<cr>]
Example	PROG:EXEC:TRANS 2
Command Syntax	PROG ram:EXECute:TRANS:RESET
Description	This command serves the same purpose as the “PROG
	ram:TRANSient STOP” command. See next.
	This command resets the active transient execution. This command is included to support UPC compatibility mode although it is not documented in the UPC manual. Not recommended for new programs.
Parameters	None
Parameter Format	n/a
Example	PROG:EXEC:TRANS:RESET

8.6.3 Transient Segments Commands

The following commands may be used to control stored transient program executions.

Command Syntax	PROG:TRANSient
Description	This command controls transient execution
Parameters	RUN STOP PAUSE STEP REStart
Parameter Format	<cr>
Example	PROG:TRAN RUN
Query Format	PROG:TRANSient?
Description	Query format returns the transient execution state as either RUN, STOP, PAUS, STEP or REST
Returned Data Format	<cr>
Query Example	PROG:TRAN? RUN
Command Syntax	PROG:TRANSient:AUTORMS <BOOLEAN>
Description	If enabled, the value of any waveform used in a transient segment is normalized in order to match the RMS set point. If disabled, the waveform is reproduced without any normalization. This function is useful for waveform substitution at the steady state level. Note: This function is related to the AUTORMS function in the steady state segment.
Parameters	[0 OFF 1 ON]
Parameter Format	
Example	PROG:TRAN:AUTORMS 1
Query Format	PROG:TRANSient:AUTORMS?
Returned Data Format	
Query Example	PROG:TRAN:AUTORMS? 1
Command Syntax	PROG:TRANSient:CR <BOOLEAN>
Description	This command enables or disables the Cycle Reset mode during transient execution. When on, Cycle Reset will resync each transient run in repeat mode to the start phase angle.
Parameters	[0 OFF 1 ON]
Parameter Format	
Example	PROG:TRAN:CR 1
Query Format	PROG:TRANSient:CR?
Returned Data Format	<nr1>
Query Example	PROG:TRAN:CR? 0

<p>Command Syntax Description</p>	<p>PROG:TRANSient:HOLD <ON OFF> This commands turns the Transient HOLD mode on or off. If ON, the power source holds the last segment values at steady state after the transient ends. If OFF, the output of the power source returns to the steady state settings in effect before the transient segment ran.</p>
<p>Parameters Parameter Format Example Query Format Returned Data Format Query Example</p>	<p>[0 OFF 1 ON] <cr> PROG:TRAN:HOLD ON PROG:TRANSient:HOLD? PROG:TRAN:MODE? 1</p>
<p>Command Syntax Description</p>	<p>PROG:TRANSient:MODE This commands selected between legacy UPC controller mode SEGMENT transient mode or STEP mode. Segment mode is backward compatible with PPS UPC controllers and use a steady state table and a transient table for each segment. A total of 99 segments can be programmed. STEP mode uses the conventional SCPI LIST system of a list of transient steps executed sequentially.</p>
<p>Parameters Parameter Format Example Query Format Returned Data Format Query Example</p>	<p>[0 SEGMENT 1 STEP] <cr> PROG:TRAN:MODE STEP PROG:TRANSient:MODE? <nr1> PROG:TRAN:MODE? 1</p>
<p>Query Format Description</p>	<p>PROG:TRANSient:PROGress? This command returns the progress status of a running transient. The response data content depends on the selected transient mode, SEGMENT or STEP. (Refer to the “PROG:TRANSient:MODE” command) The following information is returned in the order shown below. Values are separated by a “/” character:</p>
<p>Return Data Format</p>	<p>A. Progress as a percent of the total between 0 to 100. B. Current element progress. A percent between 0 and 100 of the element executing. C. Active step or segment in execution. D. Active step or segment time. In multiples of 0.2 ms. E. Total time. In multiples of 0.2 ms. F. Total number of steps or segments.</p>
<p>Returned Data Format Query Example</p>	<p><nr1> / <nr1> / <nr1> / <nr1> / <nr1> / <nr1> PROG:TRAN:PROG? 57/31/3/1554/20000/4</p>
<p><i>Continues next page</i></p>	

TRANSIENT TABLE						
TRANSIENT MODE						
			STEP	SEGMENT		
#	TIME (ms)	FREQ (Hz)	V _{AC} [V _{RMS}] A/B/C	V _{DC} [V] A/B/C	Phase [deg B/C]	
> 1	1000.0	60.00	0.00	0.00	120.00/240.0	
> 2	1000.0	60.00	0.00	0.00	120.00/240.0	
> 3	1000.0	60.00	0.00	0.00	120.00/240.0	
> 4	1000.0	60.00	0.00	0.00	120.00/240.0	

Example Return data for transient table shown above in STEP mode would be

57/31/3/1554/20000/4

- A. Progress = 57% of total time or $0.57 * 4000 \text{ ms} = 2280 \text{ ms}$
- B. Current element progress = 31% or $0.31 * 1000 \text{ ms} = 310 \text{ ms}$
- C. Active step = 3
- D. Active step time = $1554 * 0.2 \text{ ms} = 310.8 \text{ ms}$
- E. Total time = $20000 * 0.2 \text{ ms} = 4000 \text{ ms}$
- F. Total number of steps = 4.

Relationship between data fields

$A = (((\text{Summing of the element times between 1 and C-1}) / 0.2 + D) / E) * 100$

For the example $A = ((1000+1000)/0.2+1554)/20000 = 57\%$

$B = (D / (\text{Time of the element C} / 0.2)) * 100$

For the example $B = (1554/(1000/0.2))*100 = 31\%$

Query Format
Description

PROG:TRANSient:EIE?

This query command returns the active Element In Execution. An element is either a STEP when in transient STEP mode or a SEGMENT when in transient SEGMENT mode.

Note: the data returned on this query is the same as the “C” data returned by the “PROG:TRANSient:PROGress?” command.

Returned Data Format
Query Example

<nr1>
PROG:TRAN:EIE?
3

Query Format
Description

PROG:TRANSient:ETE?

This query command returns the active Element To Execute. An element is either a STEP when in transient STEP mode or a SEGMENT when in transient SEGMENT mode.

The ETE query is useful when a transient execution has been PAUSED by the “PROG:TRANSient PAUSE” command. For example, if the execution is paused in the middle of an element (step or segment) execution for element “n”, the ETE value will be “n”. If it is paused at the end of element “n”, the ETE value will be “n+1”.

Returned Data Format
Query Example

<nr1>
PROG:TRAN:ETE?
4

Command Syntax Description	<p>PROG:TRAN:MODE</p> <p>This commands selected between legacy UPC controller mode SEGMENT transient mode or STEP mode. Segment mode is backward compatible with PPS UPC controllers and use a steady state table and a transient table for each segment. A total of 99 segments can be programmed. STEP mode uses the conventional SCPI LIST system of a list of transient steps executed sequentially.</p>
Parameters Parameter Format Example Query Format Returned Data Format Query Example	<p>< 0 SEGMENT 1 STEP ></p> <p><cr></p> <p>PROG:TRAN:MODE STEP</p> <p>PROG:TRAN:MODE?</p> <p><cr></p> <p>PROG:TRAN:MODE?</p> <p>1</p>
Command Syntax Description	<p>PROG:TRAN:CSC</p> <p>This command turns the CSC Mode during transient execution on (1) or off (0). This allows load regulation adjustment during transient execution. However, keep in mind that CSC adjustments are based on RMS voltage measurement, which take several cycles to run so turning on CSC on fast changing voltage transients is not recommended as the CSC may interfere with the programmed transient voltages.</p> <p>Note 1: In UPC compatibility mode, the CSC is always off during transient execution regardless of this setting to match the UPC controller operation.</p> <p>Note 2: This command is available on units with firmware revision 1.3.0 or higher.</p>
Parameters Parameter Format Example Query Format Returned Data Format Query Example	<p>< 0 OFF 1 ON ></p> <p><cr></p> <p>PROG:TRAN:CSC ON</p> <p>PROG:TRAN:CSC?</p> <p><cr></p> <p>PROG:TRAN:CSC?</p> <p>1</p>

Command Syntax	PROG:TRANSient:FROM
Description	This command sets the first transient step number at which step mode execution is to begin. The step specified must exist or an error message will be generated.
Parameters	STEP number from 1 ~ 99
Parameter Format	<nr1>
Example	PROG:TRAN:FROM 5
Query Format	PROG:TRANSient:FROM?
Returned Data Format	<nr1>
Query Example	PROG:TRAN:FROM? 5
Command Syntax	PROG:TRANSient:TO
Description	This command sets the transient step number at which step mode execution is to end. The step specified must exist or an error message will be generated.
Parameters	STEP number from 1 ~ 99
Parameter Format	<nr1>
Example	PROG:TRAN:TO 25
Query Format	PROG:TRANSient:TO?
Returned Data Format	<nr1>
Query Example	PROG:TRAN:TO? 25
Command Syntax	PROG:TRANSient:EVENTs <nr1>
Description	This command sets the number of repetitions for executing the selected transient. A zero value is equivalent to infinite execution until aborted by "PROG:TRAN STOP" command.
Parameters	Repetition, range is 0 ~ 99999
Parameter Format	<nr1>
Example	PROG:TRAN:EVEN 5
Query Format	PROG:TRANSient:EVENTs?
Returned Data Format	<nr1>
Query Example	PROG:TRAN:EVEN? 5
Command Syntax	PROG:TRANSient:GOTO <nr1>
Description	This command forces transient execution to move to the element argument passed (STEP in STEP mode or SEGMENT in segment mode).
Parameters	ELEMENT
Parameter Format	<nr1>
Example	PROG:TRAN:GOTO 3

8.6.4 Memory Management Commands

The Program memory subsystem commands allow management of Program memory contents.

Command Syntax	PROG:MEMory <cr>
Description	This command selects the specific program memory type for storing and retrieving programs. Default is INTERNAL memory. Alternatives are RAM and USB devices. The memory type can also be specified as an optional parameter with several PROG:MEM commands where indicated in this manual.
Parameters	Memory types: INTERNAL RAM USB. For a complete list of available memory types, use the "PROG:MEMory:CATalog?" Command.
Parameter Format	<cr>
Example	PROG:MEM USB
Query Format	PROG:MEMory?
Returned Data Format	<cr>
Query Example	PROG:MEM? USB
Query Format	PROG:MEMory:CATalog?
Description	This query command returns a comma separated list of available memory types that can be selected for storage of steady state and transient table information.
Returned Data Format	INTERNAL, RAM, SD1, SD2, SD3, USB
Memory Types	INTERNAL = Internal Flash Memory. (Default selection) RAM = Internal RAM. Content will be lost when power source is turned off. USB[X][Y] = USB memory stick devices. X = port number, Y = partition number SD[Y] = SC Card, Y = partition number X = symbolizes different memory sticks connected to various available USB ports. Y = symbolizes different logical partitions on a USB memory stick or SD card. INTERNAL and RAM are always available. INTERNAL is default selection. Use the "PROG:MEMory <cr>" command to select active memory selection.
Query Example	PROG:MEM:CAT? INTERNAL,RAM,USBA1

<p>Query Format Description</p>	<p>PROG:EXECuted:MEMory?</p> <p>This command selects the specific program memory type for storing and retrieving programs. Default is INTERNAL memory. Alternatives are RAM and USB devices. The memory type can also be specified as an optional parameter with several PROG:EXEC commands where indicated in this manual.</p>
<p>Parameters Parameter Format Example Query Format Returned Data Format Query Example</p>	<p>Memory types: INTERNAL RAM USB</p> <p><cr></p> <p>PROG:EXEC:MEM USB</p> <p>PROG:EXECuted:MEMory?</p> <p><cr></p> <p>PROG:EXEC:MEM?</p> <p>USB</p>
<p>Command Syntax Description</p>	<p>PROG:POWOn <nr1></p> <p>Returns the number of the stored program that will be recalled at power on.</p>
<p>Parameters Parameter Format Example Query Format Returned Data Format Query Example</p>	<p>Program number</p> <p><nr1></p> <p>PROG:POWO 1</p> <p>PROG:POWOn?</p> <p><nr1></p> <p>PROG:POWO?</p> <p>1</p>
<p>Command Syntax Description</p>	<p>PROG:DELeTe:ALL <cr></p> <p>This command deletes all programs, waveforms and setup values, performs device RESET, loads Program #1 with *RST default values, executes MANUAL MODE with *RST values. Waveforms (1-16) are re-loaded from internal Flash memory. Attempting to DELeTe an EXECuting Program will result in an error message.</p>
<p>Parameters Parameter Format Example</p>	<p>Optional: Memory type: INTERNAL RAM USB</p> <p><cr></p> <p>PROG:DEL:ALL USB</p>
<p>Query Format Description</p>	<p>PROG:CATalog? <cr></p> <p>This query returns a comma separated list of <nr1> values representing stored programs (e.g. 1,2,7...). If the MANUAL MODE program setup exists, the list will include 0. If no programs are stored at all, this query returns a 1</p>
<p>Parameters Parameter Format Returned Data Format Query Example</p>	<p>Optional: Memory type: INTERNAL RAM USB</p> <p><cr></p> <p><nr1>,<nr1>,...,<nr1>,<nr1></p> <p>PROG:CAT?</p> <p>0,1,2,9,12</p> <p>PROG:CAT? INTERNAL</p> <p>0</p>

<p>Query Format</p> <p>Description</p> <p>Parameters</p> <p>Parameter Format</p> <p>Returned Data Format</p> <p>Query Example</p>	<p>PROGram:CRC? <cr></p> <p>This query command calculates and returns the checksum value of the selected program. This CRC may be used to verify the program data integrity is intact. This command is provided for UPC compatibility mode and not recommended for new programs.</p> <p>Optional: Memory type: INTERNAL RAM USB</p> <p><cr></p> <p><nr1></p> <p>PROG:CRC? RAM</p> <p>08ad55</p>
<p>Query Format</p> <p>Description</p> <p>Parameters</p> <p>Parameter Format</p> <p>Returned Data Format</p> <p>Query Example</p>	<p>PROGram:BROWse?</p> <p>This command returns the list of available programs stored in the memory selected or passed as a parameter.</p> <p>Optional: Memory type: INTERNAL RAM USB</p> <p><cr></p> <p><nr1>, <nr1>,...,<nr1></p> <p>PROG:BROW?</p> <p>1,8,9,23</p>
<p>Query Format</p> <p>Description</p> <p>Returned Data Format</p> <p>Query Example</p>	<p>PROGram:WFBANK?</p> <p>This query command returns the waveform bank number. It is provided for UPC compatibility mode and not recommended for new programs. It always returns a minus one (-1) response.</p> <p>-1</p> <p>PROG:WFBANK?</p> <p>-1</p>
<p>Query Format</p> <p>Description</p> <p>Returned Data Format</p> <p>Query Example</p>	<p>PROGram:WFCRC?</p> <p>This query command calculates and returns the checksum value of all waveforms. The CRC may be used to verify the waveform data integrity is intact. This command is provided for UPC compatibility mode and not recommended for new programs.</p> <p><nr1></p> <p>PROG:WFCRC?</p> <p>-31893,18622,25404,-20201,15032,-2662,-28577,-5178,-3736,-23017,-19989,-25093,-2813,3096,-32131,4403</p>

8.7 Source Commands

Source commands control the settings of the power source. This includes all operating modes, voltages, frequency, current and power limits and phase angles as well as transient operation. Since the SOURCE subsystem is the primary system, the SOURce portion of these commands is optional. The following status commands are supported broken down by SOURCE sub groups.

8.7.1 Source Configuration Programming Commands

Command Syntax	[SOURce:]CONFIG
Description	Selects alternative loop compensation mode for improved transient response. The effect of this command depends on the selected output mode as follows: AC Mode: Changes the AC loop compensation DC Mode: Changes the DC loop compensation AC+DC Mode: Changes both the AC and DC loop compensations Note: The alternative compensation configuration setting is saved separately saved for DC and AC (only and +DC). When changed to off while in DC mode, it will be saved as off for DC only. Also if you are in AC only (or AC+DC) and you change it to 1, it is saved separately.
Parameters	< 0 1 > (0 = Normal loop, 1 = Faster Loop)
Parameter Format	
Example	SOUR:CONFIG 1
Query Format	[SOURce:]CONFIG?
Returned Data Format	
Query Example	CONFIG? 0
Command Syntax	[SOURce:]CONFIG:AC
Description	Selects alternative AC loop compensation mode for improved AC transient response. The effect of this command depends on the selected output mode as follows: AC Mode: Changes the AC loop compensation DC Mode: No effect AC+DC Mode: Changes the AC loop compensations Note: Available in units with Firmware revision 1.6.0 or higher.
Parameters	< 0 1 > (0 = Normal loop, 1 = Faster Loop)
Parameter Format	
Example	SOUR:CONFIG:AC 1
Query Format	[SOURce:]CONFIG:AC?
Returned Data Format	
Query Example	CONFIG:AC? 0

<p>Command Syntax Description</p>	<p>[SOURCE:]CONFIG:DC </p> <p>Selects alternative DC loop compensation mode for improved DC transient response.</p> <p>The effect of this command depends on the selected output mode as follows:</p> <p>AC Mode: No effect DC Mode: Changes the DC loop compensation AC+DC Mode: No effect</p> <p>Note: Available in units with Firmware revision 1.6.0 or higher.</p>
<p>Parameters Parameter Format Example Query Format Returned Data Format Query Example</p>	<p>< 0 1 > (0 = Normal loop, 1 = Faster Loop)</p> <p></p> <p>SOUR:CONFIG:DC 1</p> <p>[SOURCE:]CONFIG:DC?</p> <p></p> <p>CONFIG:DC?</p> <p>0</p>

<p>Command Syntax Description</p>	<p>[SOURCE:]CONFIG:HFreq </p> <p>This command enables high-frequency output current protection extension mode. In this mode, the protection for high frequency content at the output of the power source is held off for up to 2 seconds to allow short time events to ride through without tripping the normal protection mode.</p> <p>Note: Available in units with Firmware revision 1.6.6 or higher.</p>
<p>Parameters Parameter Format Example Query Format Returned Data Format Query Example</p>	<p>< 0 OFF 1 ON > (0 = Off, 1 = On)</p> <p></p> <p>SOUR:CONFIG:HF 1</p> <p>[SOURCE:]CONFIG:HFreq?</p> <p></p> <p>CONFIG:HF?</p> <p>1</p>

Command Syntax	[SOURce:]COUPLing <cr>
Description	<p>Selects the output coupling mode. On AFX Series®, this command only accepts DIRECT as a setting unless the optional output transformer is connected and configured. The output voltage ratio of the transformer can be queried using the “SYSTem:XFMRATIO?” command. The output voltage range is 300Vac x Ratio full scale Line to Neutral.</p> <p>If no transformer option is installed and configured, selecting XMFR coupling will generate a 2019 Error code. Do not select XMFR coupling if the SYSTem:XFMRATIO? query returns a 0.0000 value.</p>
Parameters	<p>< DIRECT 0 XMFR 1 ></p> <p>0 = DIRECT</p> <p>1 = XMFR</p>
Parameter Format	<cr>
Example	COUPL DIRECT
Query Format	[SOURce:]COUPLing?
Returned Data Format	<cr>
Query Example	COUPL? 0

Command Syntax	[SOURce:]INITial <n>
Description	Sets source output settings initialization mode. This command in combination with the "OUTPut[:STATE]:AUTO" command allows the unattended resumption of a test station after a power failure. Note: This condition is potentially hazardous and should be used with caution.
[SOURce:]INITial? = ON	Set points of the unit at power on will be the last set after power off. The set points affected by this command are: - Frequency - Voltage AC1 - Voltage AC2 - Voltage AC3 - Voltage DC1 - Voltage DC2 - Voltage DC3 - Form (THREE , SPLIT or SINGLE) - Range (High or Low) - Compatibility Mode (UPC or NORMAL)
[SOURce:]INITial? = OFF	Set points of the unit at power on will have a default value of: - Frequency = 60Hz - Voltage AC1 = 0V - Voltage AC2 = 0V - Voltage AC3 = 0V - Voltage DC1 = 0V - Voltage DC2 = 0V - Voltage DC3 = 0V - Form = THREE - Range = HIGH - Compatibility = NORMAL
Parameters	< 0 OFF 1 ON >
Parameter Format	
Example	:INIT ON
Query Format	[SOURce:]INITial?
Returned Data Format	
Query Example	INIT? 0
Command Syntax	[SOURce:]FORM <nr1>
Description	Set phase mode or FORM. Allowable arguments are 1, 2 or 3.
Parameters	< 1 2 3 >
Parameter Format	<nr1>
Example	FORM 3
Query Format	[SOURce:]FORM?
Returned Data Format	<nr1>
Query Example	FORM? 3

<p>Command Syntax Description</p>	<p>[SOURCE:]RANGe Selects high or low voltage range. Although the AFX Series® has only a single voltage range, this commands allows simulation of a dual range AC voltage source which is more familiar to some users. Despite this virtual low range capability, no actual physical range change takes places so the output is never interrupted. Note: When switching from HIGH to LOW range, the output voltage may be reduced to the highest available voltage on the low range.</p>
<p>Parameters Parameter Format Example Query Format Returned Data Format Query Example</p>	<p>< 0 LOW 1 HIGH > RANG HIGH [SOURCE:]RANGe? RANG? 1</p>
<p>Command Syntax Description</p>	<p>[SOURCE:]RAMP# Sets voltage slew rate for selected phase number or for all phases if no phase number is specified.</p>
<p>Parameters Parameter Format Example Query Format Description Returned Data Format Query Example</p>	<p>Slew rate <nr2> SOUR:RAMP3 10.5 [SOURCE:]RAMP#? Returns voltage slew rate setting for specified phase (1, 2 or 3) or for phase 1 (A) if no phase number is specified. SOUR:RAMP3? 10.5000</p>
<p>Command Syntax Description</p>	<p>[SOURCE:]SERIES Changes output configuration to series connection on AFXS units when set to ON. Requires the SPMS (Series parallel Mode Stich) hardware option. Returns to parallel output connection mode when OFF.</p>
<p>Parameters Parameter Format Example Query Format Description Returned Data Format Query Example</p>	<p>< 0 OFF 1 ON > <nr1> SERIES ON [SOURCE:]SERIES? Returns Series Mode setting on AFXS models. SOUR:SERIES? 1</p>

Command Syntax	[SOURce:]UPDATEPHase
Description	Set the phase angle at which programmed voltage changes on phase A will take place. This applies to output on and off phase angle placement as well. Available range is from 0° through 360.0° inclusive. Values higher than 360.0° will be truncated to 360.0000° automatically.
Parameters	< 0.0000 - 360.0000 >
Parameter Format	<nr2>
Example	UPDATEPH 90.00
Query Format	[SOURce:]UPDATEPHase?
Returned Data Format	<nr2>
Query Example	SOURce:UPDATEPH? 90.0000

8.7.2 Voltage Programming Commands

Note that most of the voltage programming commands are phase specific so in three or split phase mode, each phase voltage can be individually programmed. This is done by appending 1, 2 or 3 for the “#” symbol shown in the syntax below. If the “#” value is omitted, all available phase (1, 2 or 3 in single, split or three phase mode respectively) will be set to the same amplitude. This allows the same program code to be used for any phase mode as long as the phase amplitudes need to be balanced.

The following command sets each phase to a different amplitude when in three phase mode.

```
SOUR:VOLT:AC1 15;;SOUR:VOLT:AC2 30;;SOURCE:VOLT:AC3 45
```

This command sets all phases to the same amplitude, regardless of phase mode:

```
SOUR:VOLT:AC 100
```

The query format for these phase specific commands will return the value for the phase number appended to the command. If the phase number reference is omitted, the setting for phase 1 (A) is returned.

Command Syntax	[SOURCE:]VOLTage:MODE
Description	Results voltage mode as 0 for AC, 1 for DC or 2 for ACDC. Note: In UPC compatibility mode, only AC mode is available
Parameters	< 0 AC 1 DC 2 ACDC >
Parameter Format	<nr1>
Example	VOLT:MODE DC
Query Format	[SOURCE:]VOLTage:MODE?
Returned Data Format	<nr1>
Query Example	VOLT:MODE? 1
Command Syntax	[SOURCE:]VOLTage:CSC[:STATE#] [SOURCE:]CSC:STATE#
Description	Turns the Continuous Source Calibration (CSC) mode on or off.
Parameters	<0 OFF 1 ON>
Parameter Format	
Example	VOLT:CSC ON
Query Format	[SOURCE:]VOLTage:CSC[:STATE]?
Returned Data Format	<nr1>
Query Example	VOLT:CSC? 1

Command Syntax	[SOURce:]VOLTage[:AC]#
Description	Sets AC voltage for phase #. If # is omitted, sets all available phases to value specified.
Parameters	Range 0.0000 - 300.0000
Parameter Format	<nr2>
Example	VOLT:AC1 100.00
Query Format	[SOURce:]VOLTage[:AC]#?
Description	Returns voltage setting for specified phase. If phase is omitted, returns voltage setting for phase A.
Returned Data Format	<nr2>
Query Example	VOLT:AC1? 100.0000
Command Syntax	[SOURce:]VOLTage[:AC]#:SLEW
Description	Sets AC voltage slew rate for phase # in Volts per msec. If # is omitted, sets phase A slew rate to value specified.
Parameters	Range 0.01 – 300.0
Parameter Format	<nr2> and <nr3>
Example	VOLT:AC1:SLEW 300.00
Query Format	[SOURce:]VOLTage[:AC]#:SLEW?
Description	Returns voltage slew rate setting for specified phase. If phase is omitted, returns voltage setting for phase A.
Returned Data Format	<nr2>
Query Example	VOLT:AC1:SLEW? 300.0000
Command Syntax	[SOURce:]VOLTage[:AC]:LIMit:MINimum
Description	Sets low user limit for AC voltage programming. User limits must fall within actual hardware limits of the power source. Also, MIN limit must be less than MAX limit.
Parameters	0.000 – 300.000
Parameter Format	<nr2>
Example	VOLT:LIM:MIN 20.0
Query Format	[SOURce:]VOLTage[:AC]#:LIMit:MINimum?
Returned Data Format	<nr2>
Query Example	VOLT:LIM:MIN? 20.0000

Command Syntax	[SOURce:]VOLTage[:AC]:LIMit:MAXimum
Description	Sets high user limit for AC voltage programming. User limits must fall within actual hardware limits of the power source. Also, MAX limit must be greater than MIN limit.
Parameters	0.000 – 300.000
Parameter Format	<nr2>
Example	VOLT:LIM:MAX 240.0
Query Format	[SOURce:]VOLTage[:AC]#:LIMit:MAXimum?
Returned Data Format	<nr2>
Query Example	VOLT:LIM:MAX? 240.0000
Query Format	[SOURce:]VOLTage[:AC]#:LIMit:RANGE?
Description	Returns available AC voltage range low and high limits.
Returned Data Format	<nr2>,<nr2>
Query Example	VOLT:AC1:LIM:RANG? 0.0000,300.0000
Query Format	[SOURce:]VOLTage[:AC]#:LIMIT:SATuration:RANGE?
Description	Returns the upper and lower limit sine wave RMS voltage at which saturation of the output inverter will occur. Saturation limits are determined in the maximum peak voltage capability of the AC+DC components at the output of the power source. For the AFX Series®, these limits are -425 and +425V. The VOLT:AC1:LIM:SAT:RANG? returns the min and max. RMS of a sine wave that may be programmed based on the programmed DC component. Maximum allowable values are: Maximum positive peak voltage: $V_{peak_max} = V_{AC_peak_max} + V_{DC}$ Minimum negative peak voltage: $V_{peak_min} = V_{AC_peak_min} + V_{DC}$ For a sinusoidal AC waveform, these limits are: $V_{rms_sat} = (425 - V_{dc}) / 1.4142$ $V_{rms_sat} = (-425 + V_{dc}) / 1.4142$
Examples	$V_{DC} = 0$ $425 = 1.41 * 300 + 0$ (V_AC_rms_sat = 300) $V_{DC} = 100$ $425 = 1.41 * 229 + 100$ (V_AC_rms_sat = 229) $V_{DC} = 425$ $425 = 1.41 * 0 + 425$ (V_AC_rms_sat = 0)
Returned Data Format	<nr2>
Query Example	VOLT:AC3:LIM:SAT:RANG? 300.5204

Query Format Description	[SOURCE:]VOLTage[:AC]#:LIMIT:SATuration:MAXimum? Returns maximum sine wave RMS voltage at which saturation of the output inverter will occur. See [SOURCE:]VOLTage[:AC]#:LIMIT:SATuration:RANGe? for details.
Returned Data Format Query Example	<nr2> VOLT:AC3:LIM:SAT:MAX? 301.154
Query Format Description	[SOURCE:]VOLTage[:AC]#:LIMIT:SATuration:MINimum? Returns minimum sine wave RMS voltage at which saturation of the output inverter will occur. See [SOURCE:]VOLTage[:AC]#:LIMIT:SATuration:RANGe? for details.
Returned Data Format Query Example	<nr2> VOLT:AC3:LIM:SAT:MIN? 0.000
Command Syntax Description	[SOURCE:]VOLTage[:AC]:INITial This command is equivalent to the “[SOURCE:]INITial <n>” command but applies only to the AC1, AC2 and AC3 parameters.
VOLT:INIT? = ON	Set points of the unit at power on will be the last set after power off. The set points affected by this command are: - Voltage AC1 - Voltage AC2 - Voltage AC3
VOLT:INIT? = OFF	Set points of the unit at power on will have a default value of: - Voltage AC1 = 0V - Voltage AC2 = 0V - Voltage AC3 = 0V
Parameters	< 0 OFF 1 ON >
Parameter Format	
Example	VOLT:AC:INIT OFF
Query Format	[SOURCE:]VOLTage[:AC]:INITial?
Returned Data Format	
Query Example	VOLT:AC:INIT? 0

Command Syntax	[SOURce:]VOLTage:DC#
Description	Sets DC voltage for phase #. If # is omitted, sets all available phases to value specified. Note: Source must be in DC or AC+DC mode and UPC compatibility mode must be disabled.
Parameters	Range 0.0000 - 425.0000
Parameter Format	<nr2>
Example	VOLT:DC1 375.0
Query Format	[SOURce:]VOLTage:DC#?
Returned Data Format	<nr2>
Query Example	VOLT:DC1? 375.0000
Command Syntax	[SOURce:]VOLTage:DC#:SLEW
Description	Sets DC voltage slew rate for phase #. If # is omitted, sets all available phases to value specified. Note: Source must be in DC or AC+DC mode and UPC compatibility mode must be disabled.
Parameters	Range 0.01- 850.00
Parameter Format	<nr2> and <nr3>
Example	VOLT:DC1:SLEW 850.00
Query Format	[SOURce:]VOLTage:DC#:SLEW?
Returned Data Format	<nr2>
Query Example	VOLT:DC1:SLEW? 850.0000
Command Syntax	[SOURce:]VOLTage:DC#:LIMit:MINimum
Description	Sets low user limit for DC voltage programming for phase #. If # is omitted, sets all available phases to value specified. User limits must fall within actual hardware limits of the power source. Also, MIN limit must be less than MAX limit.
Parameters	-425.0 – 425.0
Parameter Format	<nr2>
Example	VOLT:LIM:DC1:MIN 20.0
Query Format	[SOURce:]VOLTage:DC#:LIMit:MINimum?
Returned Data Format	<nr2>
Query Example	VOLT:DC1:LIM:MIN? -425.000

Command Syntax	[SOURce:]VOLTage:DC#:LIMit:MAXimum
Description	Sets upper user limit for DC voltage programming for phase #. If # is omitted, sets all available phases to value specified. User limits must fall within actual hardware limits of the power source. Also, MIN limit must be less than MAX limit.
Parameters	-425.0 – 425.0
Parameter Format	<nr2>
Example	VOLT:LIM:DC1:MAX 270.0
Query Format	[SOURce:]VOLTage:DC#:LIMit:MAXimum?
Returned Data Format	<nr2>
Query Example	VOLT:DC1:LIM:MAX? -425.000
Query Format	[SOURce:]VOLTage:DC#:LIMit:RANGE?
Description	This query returns both upper and lower user limits for DC voltage programming.
Returned Data Format	<nr2>,<nr2>
Query Example	VOLT:DC1:LIM:RANG? -425.0000,425.0000
Query Format	[SOURce:]VOLTage:DC#:LIMit:SATuration:RANGE?
Description	Returns maximum DC voltage at which saturation of the output inverter will occur. Saturation limits are determined in the maximum peak voltage capability of the AC+DC components at the output of the power source. For the AFX Series®, these limits are -425 and +425V. The VOLT:DC1:SAT? returns the max. DC level that may be programmed based on the programmed AC wave shape and RMS level.
Examples	<p>Maximum allowable values are:</p> <p>Maximum positive peak voltage: $V_{DC} = V_{peak_max} - V_{AC_peak_max}$</p> <p>Minimum negative peak voltage: $V_{DC} = V_{peak_min} + V_{AC_peak_min}$</p> <p>V_AC = 300Vrms sine wave $V_{DC} = 425 - 1.41 * 300$ (V_DC_sat = 0)</p> <p>V_AC = 120Vrms sine wave $V_{DC} = 425 - 1.41 * 120$ (V_DC_sat = 255)</p> <p>V_AC = 0Vrms $V_{DC} = 425 - 0$ (V_DC_sat = 425)</p>
Returned Data Format	<nr2>
Query Example	VOLT:DC1:LIM:SAT:RANG? -225, + 225

Query Format	[SOURCE:]VOLTage:DC#:LIMit:SATuration:MAXimum?
Description	Returns maximum sine wave RMS voltage at which saturation of the output inverter will occur. See [SOURCE:]VOLTage:DC#:LIMit:SATuration:RANGe? for details.
Returned Data Format	<nr2>
Query Example	VOLT:DC3:LIM:SAT:MAX? 254.946
Query Format	[SOURCE:]VOLTage:DC#:LIMit:SATuration:MINimum?
Description	Returns minimum sine wave RMS voltage at which saturation of the output inverter will occur. See [SOURCE:]VOLTage:DC#:LIMit:SATuration:RANGe? for details.
Returned Data Format	<nr2>
Query Example	VOLT:DC3:LIM:SAT:MIN? -254.946
Command Syntax	[SOURCE:]VOLTage:EXTend
Description	This command grants access to a higher voltage range extension mode. When enabled, AC voltage settings up to 333V L-N are supported.
Parameters	[0 OFF 1 2] 0 = Off, 312Vac max. 1 = 320Vac max 2 = 333Vac max
Parameter Format	<bool>
Example	VOLT:EXT 1
Query Format	[SOURCE:]VOLTage:EXTend?
Returned Data Format	<nr1>
Query Example	VOLT:EXT? 1

8.7.3 Frequency Programming Commands

Command Syntax	[SOURce:]FREQuency
Description	Sets output frequency for all phases. Not valid when the source is in DC mode. Sending a FREQ command while the source is in DC mode will result in an error. The query form will return 0.000 when in DC mode.
Parameters	15.00 – 1200.0
Parameter Format	<nr2>
Example	FREQ 400.0
Query Format	[SOURce:]FREQuency?
Returned Data Format	<nr2>
Query Example	FREQ? 400.0000
Command Syntax	[SOURce:]FREQuency:EXTend
Description	Enables extended output higher frequency mode (1200Hz ~ 3000Hz) for all phases. Note that maximum voltage and power levels are reduced for extended frequency operation.
Parameters	[0 OFF 1 ON]
Parameter Format	<nr2>
Example	FREQ:EXT 1
Query Format	[SOURce:]FREQuency:EXTend?
Returned Data Format	
Query Example	FREQ:EXT? 1
Command Syntax	[SOURce:]FREQuency:LOWrange
Description	Enables extended output lower frequency mode (1Hz ~ 15Hz) for all phases. Note that maximum voltage and power levels are reduced for extended frequency operation.
Parameters	[0 OFF 1 ON]
Parameter Format	<nr2>
Example	FREQ:LOW 1
Query Format	[SOURce:]FREQuency:LOWrange?
Returned Data Format	
Query Example	FREQ:LOW? 1

<p>Command Syntax Description</p>	<p>[SOURCE:]FREQUENCY:LIMit:MINimum Sets the lower user limit for frequency programming. Not that the lower limit set value must be less than the upper limit set value or an error will be generated and no change to the set value will take place. The lower limit set value must fall within the source specified frequency range capability.</p>
<p>Parameters Parameter Format Example Query Format Returned Data Format Query Example</p>	<p>1.00 – 1200.0 <nr2> FREQ:LIM:MIN 47.0 [SOURCE:]FREQUENCY:LIMit:MINimum? <nr2> FREQ:LIM:MIN? 47.0000</p>
<p>Command Syntax Description</p>	<p>[SOURCE:]FREQUENCY:LIMit:MAXimum Sets the upper user limit for frequency programming. Note that the upper limit set value must be greater than the lower limit set value or an error will be generated and no change to the set value will take place. The upper limit set value must fall within the source specified frequency range capability.</p>
<p>Parameters Parameter Format Example Query Format Returned Data Format Query Example</p>	<p>15.00 – 3000.0 <nr2> FREQ:LIM:MAX 63.0 [SOURCE:]FREQUENCY:LIMit:MAXimum? <nr2> FREQ:LIM:MAX? 63.0000</p>
<p>Query Format Description</p>	<p>[SOURCE:]FREQUENCY:LIMit:RANGe? This command returns the lower and upper frequency user limit set value.s</p>
<p>Returned Data Format Query Example</p>	<p><nr2>, <nr2> FREQ:LIM:RANG? 53.0000,63.0000</p>
<p>Command Syntax Description</p>	<p>[SOURCE:]FREQUENCY:SLEW Sets the frequency slew rate in Hz/msec. This command is not valid when in DC mode.</p>
<p>Parameters Parameter Format Example Query Format Returned Data Format Query Example</p>	<p>0.01 – 1200.00 <nr2> FREQ:SLEW 100.0 [SOURCE:]FREQUENCY:SLEW? <nr2> FREQ:SLEW? 100.0000</p>

Query Format	[SOURce:]FREQuency:SPAN?
Description	This command is provided to support backward compatibility with Pacific Power UPC controllers. Refer also to the “ SYSTem:COMPAtible ” command. For AFX Series®, this query always returns 1200.0000
Returned Data Format	<nr2>
Query Example	FREQ:SPAN? 1200.0000

8.7.4 Current Programming Commands

Command Syntax	[SOURce:]CURRent:LIMit#
Description	This command sets the programmable current level for the selected phase #. If # is omitted, sets all phases to current level specified. The value set cannot exceed the maximum current capability of the power source as returned by the “ [SOURce:]CURRent:LIMit#:MAX? ” command. If the load current exceeds the current limit set point, the source will go into constant current mode to maintain the load current at the set limit level.
Parameters	0.00 – MAX
Parameter Format	<nr2>
Example	CURR:LIM 20.5
Query Format	[SOURce:]CURRent:LIMit#?
Returned Data Format	<nr2>
Query Example	CURR:LIM? 41.667,41.667,41.667
Query Format	[SOURce:]CURRent:LIMit#:MAX?
Description	This command returns the maximum available programmable current limit setting. Note that the returned value is a function of the “ SYSTem:COMPAtible ” setting
UPC	If UPC mode is enabled, this command always returns 2000.0000 to emulate the UPC controllers
DISABLED	With UPC mode disabled, this command returns the max. available current output per phase. This value is a function of the AFX model and the number of units that are connected in parallel.
Returned Data Format	<nr2>
Query Example	CURR:LIM:MAX? 41.6667
Query Format	[SOURce:]CURRent:LIMit#:DEFault?
Description	This command returns the default current limit setting at power up for the referenced phase.
Returned Data Format	<nr2>
Query Example	CURR:LIM1:DEF? 41.67

Query Format	[SOURce:]CURRent:LIMit#:MAXimum?
Description	This command returns the maximum current limit setting available for the referenced phase.
Returned Data Format	<nr2>
Query Example	CURR:LIM:MAX1? 41.67
Query Format	[SOURce:]CURRent:LIMit#:MINimum?
Description	This command returns the minimum current limit setting available for the referenced phase.
Returned Data Format	<nr2>
Query Example	CURR:LIM:MIN1? 0.000
Command Syntax	[SOURce:]CURRent:LIMit:AUTO
Description	This commands enables or disables the Auto Current Limit function. This function automatically adjusts the programmed current limit level as a function of programmed voltage along the constant power curve of the voltage range. For example: On a 3150AFX model in three phase mode, if VOLT = 0 and CURR:LIM = 41.67 and voltage is changed to V = 300, the CURR:LIM will change to: 5000 VA / 300 Vac = 16.0. If CURR:LIM:AUTO = OFF then the CURR:LIM setting will remain at 41.67A and the power source will power limit at 5000VA instead if the load draws more than 16Aac.
Parameters	< 0 OFF 1 ON >
Parameter Format	
Example	CURR:LIM:AUTO ON
Query Format	[SOURce:]CURRent:LIMit:AUTO?
Returned Data Format	
Query Example	CURR:LIM:AUTO? 1
Command Syntax	[SOURce:]CURRent:OVERload
Description	This command turns the overload current mode on or off
Parameters	[0 OFF 1 ON]
Parameter Format	
Example	SOUR:CURR:OV ON
Query Format	[SOURce:]CURRent:OVERload?
Returned Data Format	
Query Example	CURR:OV? 1

8.7.5 Phase Programming Commands



Command Syntax	[SOURCE:]PHAS#
Description	This command programs the phase angle for the selected phase. A phase reference (#) must be specified. Note that unless external sync mode is used, the A phase (# = 1) cannot be programmed is fixed at 0 degrees.
Parameters	0.0 – 359.9
Parameter Format	<nr2>
Example	PHAS2 122.5
Query Format	[SOURCE:]PHAS#?
Returned Data Format	<nr2>
Query Example	PHAS2? 122.5
Command Syntax	[SOURCE:]PHAS#:SLEW
Description	This command sets slew rate for the phase angle for the selected phase. A phase reference (#) must be specified. Note that unless external sync mode is used, the A phase (# = 1) slew rate cannot be programmed is fixed at 0 degrees.
Parameters	0.01 – 359.91
Parameter Format	<nr2>
Example	PHAS3:SLEW 10.25
Query Format	[SOURCE:]PHAS#:SLEW?
Returned Data Format	<nr2>
Query Example	PHAS3:SLEW? 10.2500
Command Syntax	[SOURCE:]PHAS:ROTation
Description	This command sets default phase rotation at power on. Available settings are POSITIVE (1) or NEGATIVE (0). This setting effectively swaps phases B and C and may be used to set the required phase rotation for AC motors.
Parameters	[0 NEGative 1 POSitive] 0 = NEGATIVE 1 = POSITIVE
Parameter Format	
Example	PHAS:ROT POS
Query Format	[SOURCE:]PHAS:ROTation?
Returned Data Format	
Query Example	PHAS:ROT? 1

Command Syntax	[SOURce:]PHASe:SPLIT
Description	This command sets the split phase mirroring mode. This mode allows non-symmetrical AC arbitrary waveforms to be used when in split phase mode. Default state is on.
Parameters	[0 OFF 1 ON] 0 = OFF 1 = ON
Parameter Format	
Example	PHAS:SPLIT ON
Query Format	[SOURce:]PHASe:SPLIT?
Returned Data Format	
Query Example	PHAS:SPLIT? 1
Command Syntax	[SOURce:]UPDATEPHase <nr2>
Description	This command sets the start phase angles at which any voltage or frequency setting change will take place. It also determines the start phase angle for phase A for the start of a transient execution.
Parameters	0.0 to 359.9
Parameter Format	<nr2>
Example	UPDATEPH 90.0
Query Format	[SOURce:]UPDATEPHase?
Returned Data Format	<nr2>
Query Example	UPDATEPH? 90.0

8.7.6 Waveform Programming Commands

Waveform Storage

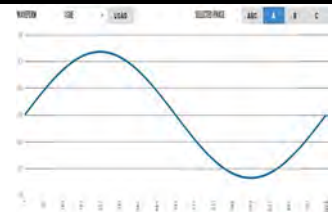
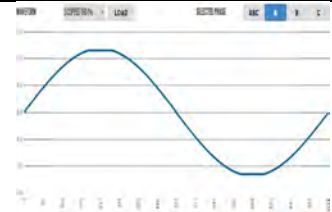
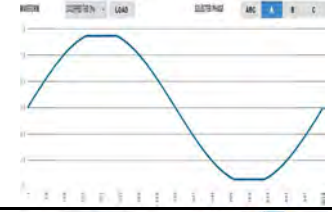
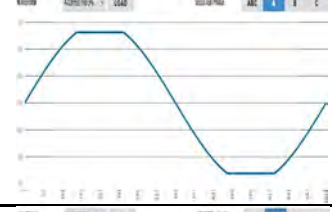
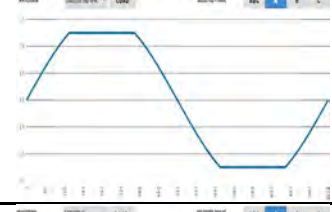
The AFX Series® offers full arbitrary waveform programming capability in addition to the standard waveforms that are provided. A total of 16 waveform registers are available. The default content of these registers is shown in the table below. Also shown are the waveform number names and the waveform description each waveform.

Name	Description	Image	Notes
1	SINE		Standard sine wave. No harmonic content. This is also the default selected waveform at power on unless a power-on setup is recalled.
2	CLIPPED THD 1%		Clipped sine with 1% total harmonic voltage distortion due to flat topping of sinewave peaks.
3	CLIPPED THD 2%		Clipped sine with 2% total harmonic voltage distortion due to flat topping of sinewave peaks.
4	CLIPPED THD 5%		Clipped sine with 5% total harmonic voltage distortion due to flat topping of sinewave peaks.
5	CLIPPED THD 10%		Clipped sine with 10% total harmonic voltage distortion due to flat topping of sinewave peaks.
6	SQUARE LF		Square wave. Consists of fundamental and all odd harmonics. The LF (low frequency) version is recommended for use below 100Hz.

Name	Description	Image	Notes
7	SQUARE HF		Square wave. Consists of fundamental and all odd harmonics. The HF (high frequency) version is recommended for use above 100Hz.
8	SAWTOOTH LF		Saw tooth. Consist of fundamental and both odd and even harmonics. Note: Not recommended for conventional power applications. LF use < 100Hz.
9	SAWTOOTH HF		Saw tooth. Consist of fundamental and both odd and even harmonics. Note: Non-linear! Not recommended for conventional power applications. HF use > 100Hz.
10	TRIANGLE		Triangle. Similar to saw tooth but at same fundamental as a sine wave. Contains fundamental and odd harmonics with amplitudes that roll off as the inverse square of the harmonic number. (1/3, 1/9, 1/25 etc).
11~200	USER DEFINED	Number, ALIAS	User defined waveforms

Table 8-2: Available Included AFX Series® Waveforms

Commands

<p>Command Syntax Description</p>	<p>[SOURCE:]WAVEFORM:AUTORMS <BOOLEAN> If enabled, the value of the waveform is normalized in order to match the RMS set point. If disabled, the waveform is reproduced without any normalization. This function is useful for waveform substitution at the steady state level. Note: This function is related to the AUTORMS function in the transient segment but it is not the same. Note: UPC has AUTORMS always enabled for steady state. It is not an option in UPC Mode.</p>
<p>Parameters Parameter Format Example Query Format Returned Data Format Query Example</p>	<p>0 1 ON OFF WAVEFORM:AUTORMS OFF [SOURCE:]WAVEFORM:AUTORMS? SOURCE:WAVEFORM:AUTORMS? 0</p>
<p>Query Format Description</p>	<p>[SOURCE:]WAVEFORM:CATalog? This command returns the list of available waveforms by name. Names can only be numbers. For more descriptive names, see the .”[SOURCE:]WAVEFORM:CATalog:ALIAS?” command instead.</p>
<p>Returned Data Format Query Example</p>	<p><cr> WAVEFORM:CAT? 1,2,3,4,5,6,7,8,9,10,11,12,13,14,15,16</p>
<p>Query Format Description</p>	<p>[SOURCE:]WAVEFORM:CATalog:ALIAS? This command returns the list of available waveforms by description. For each waveform, both the name (number) and description are returned in a comma separated list.</p>
<p>Returned Data Format Query Example</p>	<p><cr> WAVEFORM:CAT:ALIAS? Sine,Clipped THD 1%,Clipped THD 2%,Clipped THD 5%,Clipped THD 10%,Square Fast,Square Slow,Sawtooth Fast,Sawtooth Slow,Triangle,Clip 5% THD,Clip 6% THD,Clip 7% THD,Clip 8% THD,Clip 9% THD,Clip 10% THD</p>
<p>Command Syntax Description</p>	<p>[SOURCE:]WAVEFORM:COPY This command copies the waveform file specified as a PATH parameter to the waveform number specified. The path name is a delimited string.</p>
<p>Parameters Parameter Format Example</p>	<p><PATH>,<NUMBER> <cr>,<nr1> WAVEFORM:COPY “internal/waveforms/1.csv”,25</p>

<p>Command Syntax Description</p>	<p>[SOURCE:]WAVEFORM:DEFine This command sends a string of 1024 data points that constitute a single period of an arbitrary waveform. The data is sent as a comma separated list of <nr2> values. The waveform name to which to apply the new data values is the first parameter in the list and can be from 1 through 16. Note: Data values are scaled based on an RMS value of 1 so for a sine wave, the max data value is 1.414 and the min data value is -1.414 1024 data values separated by commas</p>
<p>Parameters Parameter Format Example</p>	<p><nr1>,<nr2>, <nr2>,.....,<nr2> WAVEFORM:DEF 16,0.0000,0.0068,0.0135,0.0203,....,-0.0203,-0.0135,-0.0068</p>
<p>Query Format Returned Data Format Query Example</p>	<p>[SOURCE:]WAVEFORM:DEFine? <nr1> <nr2>, <nr2>,.....,<nr2> SOURCE:WAVEFORM:DEF? 16 0.0000,0.0068,0.0135,0.0203, ,-0.0203,-0.0135,-0.0068</p>
<p>Command Syntax Description</p>	<p>[SOURCE:]WAVEFORM:DElete <nr1> This command deletes a user defined waveform from any location higher than 1.</p>
<p>Parameters Parameter Format Example</p>	<p>Waveform number <nr1> WAVEFORM:DEL 16</p>
<p>Query Format Description</p>	<p>[SOURCE:]WAVEFORM:EXIST? <nr1> This command returns a 1 if the waveform location referenced contains waveform data or a 0 is the waveform location is empty (No waveform exists).</p>
<p>Returned Data Format Query Example</p>	<p><nr1> WAVEFORM:EXIST? 34 0</p>
<p>Command Syntax Description</p>	<p>[SOURCE:]WAVEFORM#:LOAD This command loads the currently selected waveform to the actual output register of the controller causing it output the waveform on the selected phase #.</p>
<p>Parameters Parameter Format Example Query Format Returned Data Format Query Example</p>	<p>1, 2, 3 <nr1> WAVEFORM1:LOAD [SOURCE:]WAVEFORM#:LOAD? <nr1> <nr1>, <cr> SOURCE:WAVEFORM1:LOAD? 1 1, Sine</p>

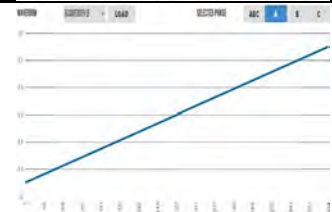
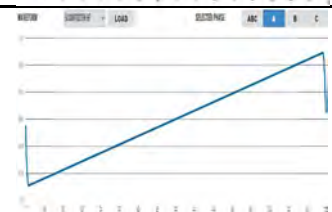
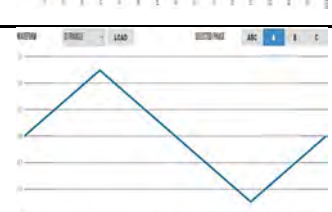
Command Syntax Description	[SOURCE:]WAVEFORM:RESTORE This command restores the first 16 waveforms registers by replacing waveform 1 to 16 with the factory defaults. See section 8.7.6. Note: This command is useful if waveforms 2 through 15 were overwritten with user-defined waveforms.
Parameters Parameter Format Example Query Format	None n/a WAVEFORM:RESTORE None
Command Syntax Description	[SOURCE:]WAVEFORM#:SElect This command selects a waveform by alias (name) or number. When using the WAVEFORM:x commands, the ALIAS NUMBER is not passed as it uses the selected one. This is to avoid passing the waveform number to every command
Parameters	<ALIAS NUMBER, OPT: ALIAS NUMBER , OPT: ALIAS NUMBER > The first parameter is required. Additional optional waveforms or numbers may be added when operating the source in 2 or 3 phase mode. The waveform selection sequence by phase is A, B, C.
Parameter Format Example	<cr> or <nr1> WAVEFORM:SEL SINE WAVEFORM:SEL 1,2,3 WAVEFORM:SEL 5
Query Format Returned Data Format Query Example	[SOURCE:]WAVEFORM#:SElect? <cr> or <nr1> WAVEFORM:SEL? 1,1,1 (FORM 3) WAVEFORM:SEL? 1,1 (FORM 2) WAVEFORM:SEL? 1 (FORM 1)

Command Syntax Description	[SOURCE:]WAVEFORM:SINEwave This command modifies the #1 Sinewave harmonic content to reduce voltage distortion at lower frequencies (< 100Hz). It does so by disabling the 3 rd Harmonic component that is normally included to improve voltage distortion at high frequencies. Turning this OFF (0) is recommended for Harmonics and Flicker system applications at 50 and 60 Hz. For Avionics and Defense applications at 400Hz or higher, this mode should re-enabled (1). Not that this setting is saved in non-volatile memory and is retained between power on/off cycles of the power source.
Parameters Parameter Format Example Query Format Query Example	 n/a SOUR:WAVEFORM:SINE 0 SOURCE:WAVEFORM:SINEwave? SOUR:WAVEFORM:SINE? 0
Command Syntax Description	[SOURCE:]WAVEFORM:SMOOTHen <NUMBER> This command Sets the smoothing filter size that is applied to the waveform, in sample counts. A value of 1 makes the filter have no effect (Disabled) and the maximum value is 101. Only odd numbers are considered. The type of filter used is a moving-average-filter, or MAF. The smoothing filter is used to reduce slew rates of waveform edges. This is useful in certain applications to make the waveform reproduction more consistent and reduce potential distortion due to the sampling rate of the controller, especially when reproducing waveforms at high frequency.
Parameters Parameter Format Example Query Format Returned Data Format Query Example	NUMBER <nr1> WAVEFORM:SMOOTH 33 [SOURCE:]WAVEFORM:SMOOTHen? <nr1> WAVEFORM:SMOOTH? 33

<p>Command Syntax Description</p>	<p>[SOURCE:]WAVEFORM#:NAME Set waveform for selected phase to the waveform name passed as a parameter. If no waveform name parameter is specified, the query format returns the name of the selected waveform. See WAVEFORM#[[:NAME]] command.</p>
<p>Parameters Parameter Format Example Query Format Returned Data Format Query Example</p>	<p>1 – 16 <nr1> WAVEFORM1 4 [SOURCE:]WAVEFORM#:NAME? <nr1> SOUR:WAVEFORM1? 4</p>
<p>Command Syntax Description</p>	<p>[SOURCE:]WAVEFORM#:ALIAS Analogous to the WAVEFORM#[[:NAME]] command but in place of the waveform name, the waveform description is passed as a quoted string.</p>
<p>Parameters Parameter Format Example Query Format Description Returned Data Format Query Example</p>	<p>Waveform description as quoted string. <cr> WAVEFORM1:NAME:ALIAS "Triangle" [SOURCE:]WAVEFORM#:ALIAS? Analogous to the WAVEFORM#[[:NAME]]? query command but in place of the waveform name, the alias is returned as a string. <cr> WAVEFORM1:ALIAS? Triangle</p>
<p>Command Syntax Description</p>	<p>[SOURCE:]WAVEFORM#:LOAD Sets the waveform name (1 – 16) to be loaded for the selected phase # for the next SWITCH command. If # is omitted, sets all available phases to waveform name specified. Note: The waveform LOAD command loads the selected phase's waveform registers with the waveform data for the specified waveform name but does not cause it to appear at the output until the WAVEFORM:SWITCH command is received.</p>
<p>Parameters Parameter Format Example Query Format Returned Data Format Query Example</p>	<p>1 – 16 <nr1> WAVEFORM2:LOAD 12 [SOURCE:]WAVEFORM#:LOAD? <nr1> or <nr1>,<nr1>,nr1> WAVEFORM:LOAD? 1,12,1</p>

Command Syntax	[SOURCE:]WAVEFORM#:SWITCH
Description	When sent for the selected phase, the output waveform is switched over to the new waveform name that was last set with the WAVEFORM#:LOAD command. . If # is omitted, sets all available phases' waveforms are switched.
Parameters	None other than phase selected in command string
Parameter Format	n/a
Example	WAVEFORM1:SWITCH

8.7.7 Voltage Protection Programming Commands

Note: For all protection commands, # = Phase 1, 2 or 3 select or omit for all phases.

Command Syntax	[SOURce:]PROTeCt:PEAK:VOLTage#:STATe
Description	This command enables or disables the peak voltage protection.
Parameters	< 0 OFF 1 } ON >
Parameter Format	
Example	PROT:PEAK:VOLT1:STAT 1
Query Format	[SOURce:]PROTeCt:PEAK:VOLTage#:STATe?
Returned Data Format	<nr1>
Query Example	PROT:PEAK:VOLT1:STAT? 1

Command Syntax	[SOURce:]PROTeCt:PEAK:VOLTage#:MODE <MARGin LEVeL BOTH>
Description	This command sets the voltage peak mode.
Parameters	<MARGin 0 LEVeL 1 BOTH 2 >
	Encoding:
	MARGin 0 Relative level
	LEVeL 1 Absolute level
	BOTH 2 Both
Parameter Format	<cr> <nr1>
Example	PROT:PEAK:VOLT1:MODE BOTH
Query Format	[SOURce:]PROTeCt:PEAK:VOLTage#:MODE?
Returned Data Format	<nr2>
Query Example	PROT:PEAK:VOLT1:MODE? 2

Command Syntax	[SOURce:]PROTeCt:PEAK:VOLTage#:MARGin <VOLTAGE MARGIN>
Description	This command sets the maximum voltage peak margin. If the output voltage peak exceeds the programmed peak margin by more than this amount, an error is tripped.
Parameters	<VOLTAGE MARGIN>
Parameter Format	<nr2>
Example	PROT:PEAK:VOLT:MARG 120.0
Query Format	[SOURce:]PROTeCt:PEAK:VOLTage#:MARGin?
Returned Data Format	<nr2>
Query Example	PROT:PEAK:VOLT1:MARG? 120.000

Query Syntax	[SOURce:]PROTeCt:PEAK:VOLTage:MARGin:MINimum?
Description	This command returns the minimum voltage peak margin setting. # = Phase 1, 2 or 3 select or none.
Query Example	PROT:PEAK:VOLT:MARG1:MIN? 0.000

Query Syntax	[SOURCE:]PROTECT:PEAK:VOLTage:MARGin:MAXimum?
Description	This command returns the maximum voltage peak margin setting
Query Example	PROT:PEAK:VOLT:MARG:MAX? 500.000
Query Syntax	[SOURCE:]PROTECT:PEAK:VOLTage:MARGin:DEFault?
Description	This command returns the default voltage peak margin setting
Query Example	PROT:PEAK:VOLT:MARG:DEF? 100.000
Command Syntax	[SOURCE:]PROTECT:PEAK:VOLTage#:LEVel <VOLTAGE LEVEL>
Description	This command sets the maximum voltage peak level. If the output voltage peak exceeds the programmed peak level by more than this amount, an error is tripped.
Parameters	<VOLTAGE LEVEL>
Parameter Format	<nr2>
Example	PROT:PEAK:VOLT1:LEV 120.0
Query Format	[SOURCE:]PROTECT:PEAK:VOLTage#:LEVel?
Returned Data Format	<nr2>
Query Example	PROT:PEAK:VOLT:LEV? 500.000
Query Syntax	[SOURCE:]PROTECT:PEAK:VOLTage:LEVel:MINimum?
Description	This command returns the minimum voltage peak level setting.
Query Example	PROT:PEAK:VOLT:LEV1:MIN? 0.000
Query Syntax	[SOURCE:]PROTECT:PEAK:VOLTage:LEVel:MAXimum?
Description	This command returns the maximum voltage peak level setting
Query Example	PROT:PEAK:VOLT:LEV:MAX? 500.000
Query Syntax	[SOURCE:]PROTECT:PEAK:VOLTage:LEVel:DEFault?
Description	This command returns the default voltage peak level setting
Query Example	PROT:PEAK:VOLT:LEV:DEF? 500.000
Query Syntax	[SOURCE:]PROTECT:PEAK:VOLTage:TRIPped?
Description	This command returns 1 if the voltage peak protection has been tripped or 0 if no trip occurred.
Query Example	PROT:PEAK:VOLT1:TRIP? 0.000
Command Syntax	[SOURCE:]PROTECT:PEAK:VOLTage:TRIPped:CLEar

Description This command clears the peak voltage protection trip status. Once cleared, the power source output can be re-enabled.

Parameters <VOLTAGE LEVEL>

Parameter Format <nr2>

Example PROT:PEAK:VOLT1:TRIP:CLE

Command Syntax **[SOURCE:]PROTECT:RMS:OV#:LEVEL <VOLTAGE LEVEL>**

Description This command sets the over-voltage level. If the output voltage exceeds the programmed level, an error is tripped.

Parameters <VOLTAGE LEVEL>

Parameter Format <nr2>

Example PROT:RMS:OV1:LEV 120.0

Query Format **[SOURCE:]PROTECT:RMS:OV#:LEVEL?**

Returned Data Format <nr2>

Query Example PROT:RMS:OV:LEV?
500.000

Command Syntax **[SOURCE:]PROTECT:RMS:OV#:STATE**

Description This command enables or disables the over-voltage level protection.

Parameters < 1 } 0 >

Parameter Format

Example PROT:RMS:OV1:LEV 120.0

Query Format **[SOURCE:]PROTECT:RMS:OV#:VOLTAGE#:STATE?**

Returned Data Format <nr2>

Query Example PROT:RMS:OV:STAT?
500.000

Command Syntax **[SOURCE:]PROTECT:RMS:UV#:LEVEL <VOLTAGE LEVEL>**

Description This command sets the under-voltage level. If the output voltage drops below the programmed level, an error is tripped.

Parameters <VOLTAGE LEVEL>

Parameter Format <nr2>

Example PROT:RMS:UV1:LEV 120.0

Query Format **[SOURCE:]PROTECT:RMS:UV#:LEVEL?**

Returned Data Format <nr2>

Query Example PROT:RMS:UV:LEV?
500.000

Command Syntax	[SOURCE:]PROTECT:RMS:UV#:STATE
Description	This command enables or disables the under-voltage level protection.
Parameters	< 1 } 0 >
Parameter Format	
Example	PROT:RMS:UV1:LEV 120.0
Query Format	[SOURCE:]PROTECT:RMS:UV#:VOLTage#:STATE?
Returned Data Format	<nr2>
Query Example	PROT:RMS:UV:STAT? 1

8.7.8 Current Protection Programming Commands

Note: For all protection commands, # = Phase 1, 2 or 3 select or omit for all phases.

Command Syntax	[SOURce:]PROTect[:RMS]:CURRent[#:STATe] <ON OFF>
Description	This command enables or disables the rms current protection. If the protection is tripped the power source output is disabled.
Parameters	< ON 1 OFF 0 >
Parameter Format	<nr1> <cr>
Example	PROTect:CURRent1 ON
Query Format	[SOURce:]PROTect[:RMS]:CURRent#[:STATe]?
Returned Data Format	<nr2>
Query Example	PROTect:CURRent? 1

Command Syntax	[SOURce:]PROTect[:RMS]:CURRent#:LEVel <LEVEL>
Description	This command sets the rms current protection level.
Parameters	< LEVEL >
Parameter Format	<nr2>
Example	PROT:CURR1:LEVel 40.0
Query Format	[SOURce:]PROTect[:RMS]:CURRent#:LEVel?
Returned Data Format	<nr2>
Query Example	PROT:CURR:LEV? 40.000

Query Syntax	[SOURce:]PROTect[:RMS]:CURRent:LEVel:MINimum?
Description	This command returns the minimum rms current protection level setting.
Query Example	PROT:CURR:LEV:MIN? 0.000

Query Syntax	[SOURce:]PROTect[:RMS]:CURRent:LEVel:MAXimum?
Description	This command returns the maximum rms current protection level setting.
Query Example	PROT:CURR:LEV:MAX? 41.667

Query Syntax	[SOURce:]PROTect[:RMS]:CURRent:LEVel:DEFault?
Description	This command returns the default rms current protection level setting. This value will be a function of the power source model.
Query Example	PROT:CURR:LEV:DEF? 41.667

<p>Command Syntax Description</p> <p>Parameters Parameter Format Example Query Format Returned Data Format Query Example</p>	<p>[SOURCE:]PROTECT[:RMS]:CURRENT#:TDELAY <DELAY> This command sets the rms current protection trip delay in 100 msec increments, i.e. as setting of 5 means 500 msec.</p> <p>< DELAY > <nr1> PROTECT:CURRE:TDELAY 5</p> <p>[SOURCE:]PROTECT[:RMS]:CURRENT#:TDELAY? <nr1> PROT:CURRE:LEV? 5</p>
<p>Query Syntax Description</p> <p>Query Example</p>	<p>[SOURCE:]PROTECT[:RMS]:CURRENT:TDELAY:MINIMUM? This command returns the minimum rms current protection trip delay setting.</p> <p>PROT:CURRE:TDELAY:MIN? 0</p>
<p>Query Syntax Description</p> <p>Query Example</p>	<p>[SOURCE:]PROTECT[:RMS]:CURRENT:TDELAY:MAXIMUM? This command returns the maximum rms current protection trip delay setting.</p> <p>PROT:CURRE:TDELAY:MAX? 3000</p>
<p>Query Syntax Description</p> <p>Query Example</p>	<p>[SOURCE:]PROTECT[:RMS]:CURRENT:TDELAY:DEFAULT? This command returns the default rms current protection trip delay setting.</p> <p>[SOURCE:]PROTECT[:RMS]:CURRENT:TDELAY:DEFAULT? 41.667</p>
<p>Query Syntax Description</p> <p>Query Example</p>	<p>[SOURCE:]PROTECT[:RMS]:CURRENT:TRIPPED? This command returns rms current protection trip status. Returns 1 if tripped or 0 if not.</p> <p>PROT:CURRE:TRIP? 41.667</p>
<p>Command Syntax Description</p> <p>Parameters Parameter Format Example</p>	<p>[SOURCE:]PROTECT[:RMS]:CURRENT:TRIPPED:CLEAR This command clears the rms current protection trip status. Once cleared, the power source output can be enabled.</p> <p>None n/a PROT:CURRE:TRIP:CLEAR</p>

Command Syntax	[SOURce:]PEAK:CURRent:LIMit <nr2>
Description	This command set the user programmable peak current protection limit. (Not available in models with -413 Option).
Parameters	Peak current
Parameter Format	<nr2>
Example	PEAK:CURR:LIM 80.0
Query Format	[SOURce:]PEAK:CURRent:LIMit?
Returned Data Format	<nr2>
Query Example	PEAK:CURR? 80.0000
Query Syntax	[SOURce:]PEAK:CURRent:LIMit:MAXIMUM?
Description	This query command returns the maximum allowable setting for the user programmable peak current protection limit. (Not available in models with -413 Option).
Returned Data Format	<nr2>
Query Example	PEAK:CURR:LIM:MAX? 104.0000
Query Syntax	[SOURce:]PEAK:CURRent:LIMit:MINIMUM?
Description	This query command returns the minimum allowable setting for the user programmable peak current protection limit. (Not available in models with -413 Option).
Returned Data Format	<nr2>
Query Example	PEAK:CURR:LIM:MIN? 0.0000
Query Syntax	[SOURce:]PEAK:CURRent:LIMit:DEFault?
Description	This query command returns the default setting for the user programmable peak current protection limit. (Not available in models with -413 Option).
Returned Data Format	<nr2>
Query Example	PEAK:CURR:LIM:DEF? 104.0000
Command Syntax	[SOURce:]PROTect:PEAK:CURRent#[[:STATe]] <ON OFF>
Description	This command enables or disables the peak current protection function.
Parameters	< ON 1 OFF 0 >
Parameter Format	<cr>
Example	PROT:PEAK:CURR1 ON
Query Format	[SOURce:]PROTect:PEAK:CURRent#[[:STATe]]?
Returned Data Format	
Query Example	PROT:PEAK:CURR1? 1

Command Syntax	[SOURCE:]PROTECT:PEAK:CURRENT#:LEVEL <LEVEL>
Description	This command sets the peak current protection level.
Parameters	< LEVEL >
Parameter Format	<nr2>
Example	PROT:PEAK:CURR1:LEV 95.0
Query Format	[SOURCE:]PROTECT:PEAK:CURRENT#:LEVEL?
Returned Data Format	
Query Example	PROT:PEAK:CURR1:LEV? 95.0000
Query Syntax	[SOURCE:]PROTECT:PEAK:CURRENT:LEVEL:MAXIMUM?
Description	This query command returns the maximum allowable setting for the peak current protection level.
Returned Data Format	<nr2>
Query Example	PROT:PEAK:CURR:LEV:MAX? 104.0000
Query Syntax	[SOURCE:]PROTECT:PEAK:CURRENT:LEVEL:MINIMUM?
Description	This query command returns the minimum allowable setting for the peak current protection level.
Returned Data Format	<nr2>
Query Example	PROT:PEAK:CURR:LEV:MIN? 104.0000
Query Syntax	[SOURCE:]PROTECT:PEAK:CURRENT:LEVEL:DEFAULT?
Description	This query command returns the default setting for the peak current protection level.
Returned Data Format	<nr2>
Query Example	PROT:PEAK:CURR:LEV:DEF? 104.0000
Query Syntax	[SOURCE:]PROTECT:PEAK:CURRENT:TRIPPED?
Description	This query command returns tripped state of the peak current protection level function. Return 1 if tripped, 0 if not.
Returned Data Format	
Query Example	PROT:PEAK:CURR:TRIP? 1
Command Syntax	[SOURCE:]PROTECT:PEAK:CURRENT:TRIPPED:CLEAR
Description	This command clears the peak current protection tripped status.
Parameters	None
Parameter Format	n/a
Example	PROT:PEAK:CURR:TRIP:CLE

8.7.9 Power Protection Programming Commands

Command Syntax	[SOURce:]POWER#:LIMit#
Description	This command sets the programmable true power limit level in kW for phase #. If # is omitted, all available phases are set to the value specified. The max available power for a phase can be obtained using the [SOURce:]POWER:LIMit#:MAX? query command.
Parameters	Limit value in kW
Parameter Format	<nr2>
Example	POW1:LIM 2.5
Query Format	[SOURce:]POWER#:LIMit#?
Returned Data Format	<nr2>
Query Example	POW:LIM1? 2.5000
Query Format	[SOURce:]POWER:LIMit#:MAX?
Description	Returns maximum available true power capability for the specified phase # in kW. If # is omitted, returns maximum available power level for all phases. Typically, this value will be the same for all phases.
Returned Data Format	<nr2>
Query Example	POW:LIM1:MAX? 5.0000
Command Syntax	[SOURce:]KVA:LIMit#
Description	This command sets the programmable apparent power limit level in kVA for phase #. If # is omitted, all available phases are set to the value specified. The max available apparent power for a phase can be obtained using the [SOURce:]KVA:LIMit#:MAX? query command.
Parameters	Limit value in kVA
Parameter Format	<nr2>
Example	KVA:LIM 2.5
Query Format	[SOURce:]KVA:LIMit#?
Returned Data Format	<nr2>
Query Example	POW:LIM1? 2.5000
Query Format	[SOURce:]KVA:LIMit#:MAX?
Description	Returns maximum available apparent power capability for the specified phase # in kVA. If # is omitted, returns maximum available apparent power levels for all phases. Typically, this value will be the same for all phases.
Returned Data Format	<nr2>
Query Example	KVA:LIM1:MAX? 5.0000

Query Format	[SOURce:]MODE#?
Description	Returns protection mode for the selected phase # (# = 1, 2, or 3). If # is omitted, returns protection mode for all phases in comma separated format. Note: When the phase suffix is 1, 2 or 3 the possible return categories are from 0 to 4. With suffix is omitted, this command will return MIXED(5) if modes for each phase are not the same. For example, if in split phase mode phase A (suffix 1) is in VOLTAGE mode but phase B (suffix 2) is in CURRENT mode, the query SOUR:MODE? you will return MIXED: SOUR:MODE1? = VOLTAGE and SOUR:MODE2? = CURRENT -> SOUR:MODE? = MIXED If both or phases are set to the same mode, the actual mode will be returned: SOUR:MODE1? = VOLTAGE and SOUR:MODE2? = VOLTAGE -> SOUR:MODE? = VOLTAGE
Returned Data Format	<cr> Available protection modes: 0 = NONE 1 = VOLTAGE 2 = CURRENT 3 = POWER 4 = KVA 5 = MIXED
Query Example	SOUR:MODE? VOLTAGE, VOLTAGE, VOLTAGE
Command Syntax	[SOURce:]PROTeCt[:RMS]:POWeR#[:STATe] <ON OFF>
Description	This command turns the true power protection on or off.
Parameters	< 0 OFF 1 ON >
Parameter Format	 <cr>
Example	PROT:POW ON
Query Format	[SOURce:]PROTeCt[:RMS]:POWeR#[:STATe]?
Returned Data Format	
Query Example	PROT:POW? 1
Command Syntax	[SOURce:]PROTeCt[:RMS]:POWeR#:LEVeL <LEVEL>
Description	This command sets the true power protection trip level. Setting is in KW.
Parameters	< LEVEL >
Parameter Format	<nr2>
Example	PROT:POW:LEV 5
Query Format	[SOURce:]PROTeCt[:RMS]:POWeR#:LEVeL?
Returned Data Format	
Query Example	PROT:POW:LEV? 5.000

Query Syntax	[SOURCE:]PROTECT[:RMS]:POWER:LEVEL:MINIMUM?
Description	This command returns the minimum true power protection level setting.
Query Example	PROT:POW:LEV:MIN? 0.000
Query Syntax	[SOURCE:]PROTECT[:RMS]:POWER:LEVEL:MAXIMUM?
Description	This command returns the maximum true power protection level setting.
Query Example	PROT:POW:LEV:MAX? 41.667
Query Syntax	[SOURCE:]PROTECT[:RMS]:POWER:LEVEL:DEFAULT?
Description	This command returns the default true power protection level setting. This value will be a function of the power source model.
Query Example	PROT:POW:LEV:DEF? 41.667
Command Syntax	[SOURCE:]PROTECT[:RMS]:POWER#:TDELAY <DELAY>
Description	This command sets the true power protection trip delay time. Setting is in multiples of 100 msec so 5 equals 500 msec.
Parameters	< LEVEL >
Parameter Format	<nr2>
Example	PROT:POW:LEV 5
Query Format	[SOURCE:]PROTECT[:RMS]:POWER#:TDELAY?
Returned Data Format	
Query Example	PROT:POW:TDELAY? 5.000
Query Syntax	[SOURCE:]PROTECT[:RMS]:POWER:TDELAY:MINIMUM?
Description	This command returns the minimum true power protection trip delay time setting.
Query Example	PROT:POW:TDELAY:MIN? 0
Query Syntax	[SOURCE:]PROTECT[:RMS]:POWER:TDELAY:MAXIMUM?
Description	This command returns the maximum true power protection trip delay time setting.
Query Example	PROT:POW:TDELAY:MAX? 3000

Query Syntax	[SOURCE:]PROTECT[:RMS]:POWER:TDELAY:DEFAULT?
Description	This command returns the default true power protection trip delay time setting.
Query Example	PROT:POW:TDELAY:DEF? 5
Query Syntax	[SOURCE:]PROTECT[:RMS]:POWER#:TRIPPED?
Description	This command returns the true power protection trip status. Returns 1 if tripped or 0 if not.
Query Example	PROT:POW:TRIP? 41.667
Command Syntax	[SOURCE:]PROTECT[:RMS]:POWER#:TRIPPED:CLEAR
Description	This command clears the true power protection trip status. Once cleared, the power source output can be enabled.
Parameters	None
Parameter Format	n/a
Example	PROT:POW:TRIP:CLEAR
Command Syntax	[SOURCE:]PROTECT[:RMS]:KVA#[:STATE] <ON OFF>
Description	This command turns the apparent power protection on or off.
Parameters	< 0 OFF 1 ON >
Parameter Format	 <cr>
Example	PROT:POW ON
Query Format	[SOURCE:]PROTECT[:RMS]:KVA#[:STATE]?
Returned Data Format	
Query Example	PROT:KVA? 1
Command Syntax	[SOURCE:]PROTECT[:RMS]:KVA#:LEVEL <LEVEL>
Description	This command sets the apparent power protection trip level. Setting is in KW.
Parameters	< LEVEL >
Parameter Format	<nr2>
Example	PROT:POW:LEV 5
Query Format	[SOURCE:]PROTECT[:RMS]:KVA#:LEVEL?
Returned Data Format	
Query Example	PROT:KVA:LEV? 5.000
Query Syntax	[SOURCE:]PROTECT[:RMS]:KVA:LEVEL:MINIMUM?
Description	This command returns the minimum apparent power protection level setting.
Query Example	PROT:KVA:LEV:MIN? 0.000

Query Syntax Description	[SOURCE:]PROTECT[:RMS]:KVA:LEVEL:MAXIMUM? This command returns the maximum apparent power protection level setting.
Query Example	PROT:KVA:LEV:MAX? 41.667
Query Syntax Description	[SOURCE:]PROTECT[:RMS]:KVA:LEVEL:DEFAULT? This command returns the default apparent power protection level setting. This value will be a function of the power source model.
Query Example	PROT:KVA:LEV:DEF? 41.667
Command Syntax Description	[SOURCE:]PROTECT[:RMS]:KVA#:TDELAY <DELAY> This command sets the apparent power protection trip delay time. Setting is in multiples of 100 msec so 5 equals 500 msec.
Parameters	< LEVEL >
Parameter Format	<nr2>
Example	PROT:KVA:LEV 5
Query Format	[SOURCE:]PROTECT[:RMS]:KVA#:TDELAY?
Returned Data Format	
Query Example	PROT:KVA:TDELAY? 5.000
Query Syntax Description	[SOURCE:]PROTECT[:RMS]:KVA:TDELAY:MINIMUM? This command returns the minimum apparent power protection trip delay time setting.
Query Example	PROT:KVA: TDELAY:MIN? 0
Query Syntax Description	[SOURCE:]PROTECT[:RMS]:KVA:TDELAY:MAXIMUM? This command returns the maximum apparent power protection trip delay time setting.
Query Example	PROT:KVA: TDELAY:MAX? 3000
Query Syntax Description	[SOURCE:]PROTECT[:RMS]:KVA:TDELAY:DEFAULT? This command returns the default apparent power protection trip delay time setting.
Query Example	PROT:KVA:TDELAY:DEF? 5
Query Syntax Description	[SOURCE:]PROTECT[:RMS]:KVA#:TRIPPED? This command returns the apparent power protection trip status. Returns 1 if tripped or 0 if not.
Query Example	PROT:KVA:TRIP? 41.667

Command Syntax	[SOURCE:]PROTECT[:RMS]:KVA#:TRIPPed:CLEar
Description	This command clears the apparent power protection trip status. Once cleared, the power source output can be enabled.
Parameters	None
Parameter Format	n/a
Example	PROT:KVA:TRIP:CLE

8.7.10 Frequency Protection Programming Commands

Command Syntax	[SOURCE:]PROTECT:RMS:UF#:LEVel <FREQ LEVEL>
Description	This command sets the under-frequency level. If the output frequency drops below the programmed level, an error is tripped.
Parameters	<VOLTAGE LEVEL>
Parameter Format	<nr2>
Example	PROT:RMS:UF1:LEV 45.0
Query Format	[SOURCE:]PROTECT:RMS:UF#:LEVel?
Returned Data Format	<nr2>
Query Example	PROT:RMSUV:LEV? 45.000

Command Syntax	[SOURCE:]PROTECT:RMS:UF#:STATE
Description	This command sets the under frequency level. If the output frequency drops below the programmed level, an error is tripped.
Parameters	< 0 1 >
Parameter Format	
Example	PROT:RMS:UV1:STAT 1
Query Format	[SOURCE:]PROTECT:RMS:UF#:STATE?
Returned Data Format	<nr1>
Query Example	PROT:RMS:UV1:STAT? 1

8.7.11 Impedance Programming Commands

These commands control the output impedance of the power source. This function requires firmware version 2.0.0 or higher.

The programmable output impedance is defined by a resistive component (R) and and inductive component (L).

Note: To enable the programmable impedance function, the output of the power source must be turned **OFF** first. Trying to enable this function while the output is ON will result in an error message.

Command Syntax
Description **[SOURCE:]IMPEdance[:R]**
This command sets the R value for the output impedance. Available programming range depends on the mode (Real-time or RMS).

Parameters <R>
Parameter Format <nr2>
Example IMPED 0.2
Query Format **[SOURCE:]IMPEdance[:R]?**
Returned Data Format <nr2>
Query Example IMPED:R?
0.200

Query Syntax
Description **[SOURCE:]IMPEdance[:R][:LIMit]:MAXimum?**
This command return the maximum allowable setting value for the R component of the output impedance.

Parameters None
Parameter Format N/A
Query Example IMPED:R:MAX?
1.000

Query Syntax
Description **[SOURCE:]IMPEdance[:R][:LIMit]:MINimum?**
This command return the minimum allowable setting value for the R component of the output impedance.

Parameters None
Parameter Format N/A
Query Example IMPED:R:MIN?
-1.000

Command Syntax
Description **[SOURCE:]IMPEdance:L**
This command sets the L value for the output impedance. Available programming range is -0.00000000 ~ 0.00005000 (Henry).

Parameters <L>
Parameter Format <nr2>
Example IMPED:L 0.00002
Query Format **[SOURCE:]IMPEdance:L?**
Returned Data Format <nr2>
Query Example IMPED:L?
0.00002

Query Syntax
Description **[SOURCE:]IMPEdance:L[:LIMit]:MAXimum?**
This command return the maximum allowable setting value for the L component of the output impedance.

Parameters None
Parameter Format N/A
Query Example IMPED:L:MAX?
0.00005000

<p>Query Syntax Description</p> <p>Parameters Parameter Format Query Example</p>	<p>[SOURCE:]IMPEdance:L[:LIMit]:MINimum?</p> <p>This command return the minimum allowable setting value for the L component of the output impedance.</p> <p>None N/A IMPED:L:MIN? 0.00000000</p>
<p>Command Syntax Description</p> <p>Parameters Parameter Format Example Query Format Returned Data Format Query Example</p>	<p>[SOURCE:]IMPEdance:MODE</p> <p>This command sets the programmable impedance mode to either Real-Time mode (0) or RMS Mode (1). See page 168 for a description of both impedance modes.</p> <p>0 Real mode. 1 RMS mode.</p> <p>Note: To change programmable impedance modes, the output of the power source must be turned OFF first. Trying to change modes while the output is ON will result in an error message.</p> <p>< 0 1 > IMPED:MODE 1 [SOURCE:]IMPEdance:MODE? IMPED:MODE? 1</p>
<p>Command Syntax Description</p> <p>Parameters Parameter Format Example Query Format Returned Data Format Query Example</p>	<p>[SOURCE:]IMPEdance:STATe</p> <p>This command sets the programmable impedance state to either Off (0) or On (1).</p> <p>Note: To enable the programmable impedance function, the output of the power source must be turned OFF first. Trying to enable this function while the output is ON will result in an error message.</p> <p>< 0 1 > IMPED:STAT 1 [SOURCE:]IMPEdance:STATe? IMPED:STAT? 1</p>

8.7.12 STEP Transient Commands

The command in this section control STEP transients. Some of these commands have the option to specify **NOR**mal or **SAT**urate.

SATurate mode: If a dwell time setting is out of limits, the dwell time will saturate to the limit min/max and it will not trip an error.

NORmal mode: If a dwell time setting is out of limits, an error will be generated and the dwell time setting will not be modified.

Command Syntax	[SOURCE:]STEP:MODE < INIDEL 0 FINDEL 1 INIFIN 2 >
Description	This command sets the programming mode for a STEP Transient. 0 INIDEL Allows programming the step by initial and delta values 1 FINDEL Allows programming the step by final and delta values 2 INIFIN Allows programming the step by initial and final values
Parameters	< INIDEL 0 FINDEL 1 INIFIN 2 >
Parameter Format	<cr> or <nr1>
Example	STEP:MODE 1
Query Format	[SOURCE:]STEP:MODE?
Returned Data Format	<nr1>
Query Example	STEP:MODE? 1

Query Syntax	[SOURCE:]STEP:MODE:CATalog?
Description	This command returns the available mode settings for a STEP Transient. 0 INIDEL Allows programming the step by initial and delta values 1 FINDEL Allows programming the step by final and delta values 2 INIFIN Allows programming the step by initial and final values
Returned Data Format	<nr1>
Query Example	STEP:MODE:CAT? 0,Initial and delta,1,Final and delta,2,Initial and final

Command Syntax	[SOURCE:]STEP:INITialvalue <OFF 0 ON 1>
Description	This command determines if an initial value step is inserted at the beginning of each repeat of a step transient. 0 ON Allows programming the step by initial and delta values 1 OFF Allows programming the step by final and delta values
Parameters	< OFF 0 ON 1 >
Parameter Format	<cr> or <nr1>
Example	STEP:INIT ON
Query Format	[SOURCE:]STEP:INITialvalue?
Returned Data Format	
Query Example	STEP:INIT? 1

The impact of inserting the initial value (ON) or not (OFF) is illustrated in the figure below.

- The top sequence shows a STEP transient repeated 3 times with STEP:INIT set ot OFF. The output will not return to the initial output setting between repetitions.
- The bottom sequence is the same STEP transient with STEP:INIT set to ON. Each repeat will start from the initial set value so each repititon produces the same output levels.

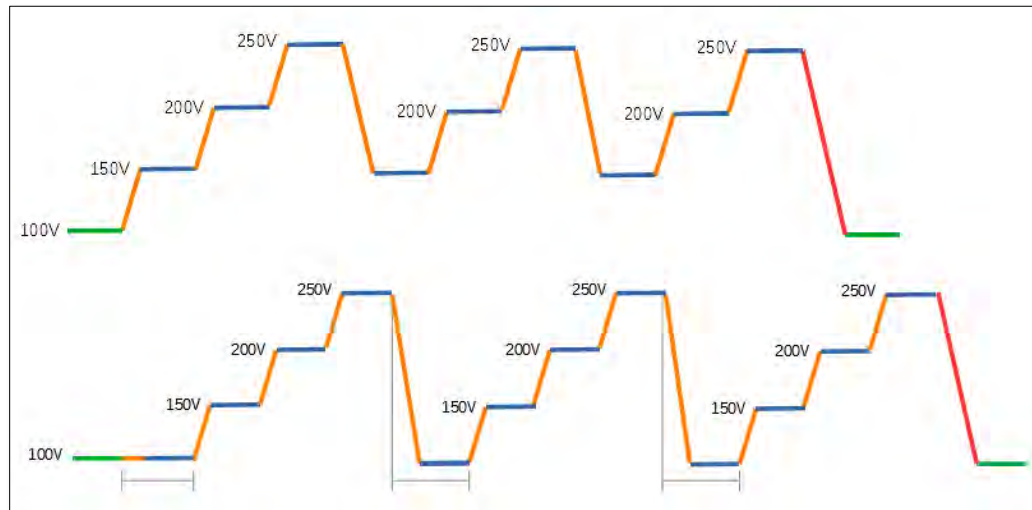

<p>Command Syntax</p> <p>Description</p> <p>Parameters</p> <p>Parameter Format</p> <p>Example</p> <p>Query Format</p> <p>Returned Data Format</p> <p>Query Example</p>	<p>[SOURCE:]STEP:DWELL <time>, <opt></p> <p>This command sets the dwell time of the step in seconds Minimum time set value allowed is 0.0002 sec. (0.2 msec)</p> <p>Time in seconds, Option: < NORMal SATurate > Default is NORMal if optional second parameter is omitted.</p> <p><nr2>, <cr></p> <p>STEP:MODE:DWELL 10, SAT</p> <p>[SOURCE:]STEP:MODE?</p> <p><nr2></p> <p>STEP:MODE:DWELL?</p> <p>10.0000, SAT</p>
<p>Query Syntax</p> <p>Description</p> <p>Returned Data Format</p> <p>Query Example</p>	<p>[SOURCE:]STEP:DWELL:MINimum?</p> <p>This command returns lowest permissible set value for the STEP dwell time setting.</p> <p><nr2></p> <p>STEP:DWELL:MIN?</p> <p>Query return values for MINimum, MAXimum and DEFault are dependent on MODE and interdependent parameter value settings</p>
<p>Query Syntax</p> <p>Description</p> <p>Returned Data Format</p> <p>Query Example</p>	<p>[SOURCE:]STEP:DWELL:MAXimum?</p> <p>This command returns highest permissible set value for the STEP dwell time setting.</p> <p><nr2></p> <p>STEP:DWELL:MAX?</p> <p>Query return values for MINimum, MAXimum and DEFault are dependent on MODE and interdependent parameter value settings</p>

<p>Query Syntax Description</p> <p>Returned Data Format Query Example</p>	<p>[SOURCE:]STEP:DWELL:DEFault? This command returns default set value for the STEP dwell time setting.</p> <p><nr2> STEP:DWELL:DEF? 0.0998</p>
<p>Command Syntax Description</p> <p>Parameters</p> <p>Parameter Format Example Query Format Returned Data Format Query Example</p>	<p>[SOURCE:]STEP:RAMP <time>, <opt> This command sets the ramp time of the step in seconds Minimum time set value allowed is 0.0002 sec. (0.2 msec) Time in seconds, Option: < NORmal SATurate > Default is NORmal if optional second parameter is omitted.</p> <p><nr2>, <cr> STEP:MODE:RAMP 5, SAT</p> <p>[SOURCE:]STEP:RAMP? <nr2> STEP:RAMP? 5.0000, SAT</p>
<p>Query Syntax Description</p> <p>Returned Data Format Query Example</p>	<p>[SOURCE:]STEP:RAMP:MINimum? This command returns lowest permissible set value for the STEP ramp time setting.</p> <p><nr2> STEP:RAMP:MIN? Query return values for MINimum, MAXimum and DEFault are dependent on MODE and interdependent parameter value settings</p>
<p>Query Syntax Description</p> <p>Returned Data Format Query Example</p>	<p>[SOURCE:]STEP:RAMP:MAXimum? This command returns highest permissible set value for the STEP ramp time setting.</p> <p><nr2> STEP:RAMP:MAX? Query return values for MINimum, MAXimum and DEFault are dependent on MODE and interdependent parameter value settings</p>
<p>Query Syntax Description</p> <p>Returned Data Format Query Example</p>	<p>[SOURCE:]STEP:RAMP:DEFault? This command returns default set value for the STEP ramp time setting.</p> <p><nr2> STEP:RAMP:DEF? Query return values for MINimum, MAXimum and DEFault are dependent on MODE and interdependent parameter value settings</p>

Command Syntax	[SOURCE:]STEP:LENGth <time>, <opt>
Description	This command sets the ramp time of the step in seconds Minimum time set value allowed is 0.0002 sec. (0.2 msec)
Parameters	Time in seconds, Option: < NORmal SATurate > Default is NORmal if optional second parameter is omitted.
Parameter Format	<nr2>, <cr>
Example	STEP:MODE:LENG 5, SAT
Query Format	[SOURCE:]STEP:LENGth?
Returned Data Format	<nr2>
Query Example	STEP:LENG? 5.0000, SAT
Query Syntax	[SOURCE:]STEP:LENGth:MINimum?
Description	This command returns lowest permissible set value for the STEP length time setting.
Returned Data Format	<nr2>
Query Example	STEP:LENG:MIN? Query return values for MINimum, MAXimum and DEFault are dependent on MODE and interdependent parameter value settings
Query Syntax	[SOURCE:]STEP:LENGth:MAXimum?
Description	This command returns highest permissible set value for the STEP length time setting.
Returned Data Format	<nr2>
Query Example	STEP:LENG:MAX? Query return values for MINimum, MAXimum and DEFault are dependent on MODE and interdependent parameter value settings
Query Syntax	[SOURCE:]STEP:LENGth:DEFault?
Description	This command returns default set value for the STEP length time setting.
Returned Data Format	<nr2>
Query Example	STEP:LENG:DEF? Query return values for MINimum, MAXimum and DEFault are dependent on MODE and interdependent parameter value settings
Command Syntax	[SOURCE:]STEP:REPeat <no, opt>
Description	This command sets the number of repeat times for the ramp of the step
Parameters	No of repeats, Option: < NORmal SATurate > Default is NORmal if optional second parameter is omitted.
Parameter Format	<nr1>, <cr>
Example	STEP:MODE:REP 100
Query Format	[SOURCE:]STEP:REP?
Returned Data Format	<nr2>
Query Example	STEP:REP? 100, NOR

Query Syntax	[SOURCE:]STEP:REPeat:MINimum?
Description	This command returns lowest permissible set value for the STEP length time setting.
Returned Data Format	<nr1>
Query Example	STEP:REP:MIN? 0
Query Syntax	[SOURCE:]STEP:REPeat:MAXimum?
Description	This command returns highest permissible set value for the STEP length time setting.
Returned Data Format	<nr1>
Query Example	STEP:REP:MAX? 65535
Query Syntax	[SOURCE:]STEP:REPeat:DEFault?
Description	This command returns default set value for the STEP length time setting.
Returned Data Format	<nr2>
Query Example	STEP:REP:DEF? 1
Command Syntax	[SOURCE:]STEP:COUNT <no, opt>
Description	This command sets the number of steps count.
Parameters	No of step count, Option: < NORmal SATurate > Default is NORmal if optional second parameter is omitted.
Parameter Format	<nr1>, <cr>
Example	STEP:MODE:REP 12
Query Format	[SOURCE:]STEP:COUNT?
Returned Data Format	<nr2>
Query Example	STEP:REP? 12, NOR
Query Syntax	[SOURCE:]STEP:COUNT:MINimum?
Description	This command returns lowest permissible set value for the STEP count setting.
Returned Data Format	<nr1>
Query Example	STEP:COUNT:MIN? 1
Query Syntax	[SOURCE:]STEP:COUNT:MAXimum?
Description	This command returns highest permissible set value for the STEP count setting.
Returned Data Format	<nr1>
Query Example	STEP:COUNT:MAX? 200

Query Syntax	[SOURce:]STEP:COUNT:DEFault?
Description	This command returns default set value for the STEP count setting.
Returned Data Format	<nr2>
Query Example	STEP:COUNT:DEF? 10
Command Syntax	[SOURce:]STEP:HOLD < 0 OFF 1 ON >
Description	This command determines what happens to the source output after the step transient finishes. If ON, the last step value will be set as the steady state output when the step execution ends. If OFF, the output will revert to the original steady state setting in effect before the step transient execution.
Parameters	< 0 OFF 1 ON >
Parameter Format	<cr>
Example	STEP:HOLD ON
Query Format	[SOURce:]STEP:HOLD?
Returned Data Format	
Query Example	STEP:HOLD? 1
Command Syntax	[SOURce:]STEP:VOLTage[:AC][:iNITial]# < nr2 >, <cr> [SOURce:]STEP:VOLTage[:AC][:iNITial]#
Description	Voltage phase A, OPT: Voltage phase B, OPT: Voltage phase C, OPT This command sets the initial STEP voltage for selected phase # or for all phases if phase reference is omitted. Note: If you get the following error, check the STEP:MODE setting as the parameter you are trying to program is the depending one. Execution error: Not allowed command with the current configuration. Either set one of the othe STEP parameters or change the MODE. Note: If you get this error, check the min or max range for this parameter. Parameter above maximum unit scope.
Parameters	Voltage , < NORmal SATurate > Default is NORmal if optional second parameter is omitted.
Parameter Format	<nr2>, <cr>
Example	STEP:VOLT1 230.00, SAT
Query Format	[SOURce:]STEP:VOLTage[:AC][:iNITial]#?
Returned Data Format	<nr2> <nr2>, <nr2>, <nr2>
Query Example	STEP:VOLT1? 230.0000

Query Syntax	[SOURCE:]STEP:VOLTage[:AC][:INITial]#:MINimum?
Description	This command returns the minimum permissible set value for the initial STEP voltage for selected phase # or for all phases if phase reference is omitted
Returned Data Format	<nr2>
Query Example	STEP:VOLT1:MIN? Query return values for MINimum, MAXimum and DEFault are dependent on MODE and interdependent parameter value settings
Query Syntax	[SOURCE:]STEP:VOLTage[:AC][:INITial]#:MAXimum?
Description	This command returns the maximum permissible set value for the initial STEP voltage for selected phase # or for all phases if phase reference is omitted
Returned Data Format	<nr2>
Query Example	STEP:VOLT1:MAX? Query return values for MINimum, MAXimum and DEFault are dependent on MODE and interdependent parameter value settings
Query Syntax	[SOURCE:]STEP:VOLTage[:AC][:INITial]#:DEFault?
Description	This command returns the default set value for the initial STEP voltage for selected phase # or for all phases if phase reference is omitted
Returned Data Format	<nr2>
Query Example	STEP:VOLT1:DEF? Query return values for MINimum, MAXimum and DEFault are dependent on MODE and interdependent parameter value settings
Command Syntax	[SOURCE:]STEP:VOLTage[:AC]:FINal# < nr2 >, <cr> [SOURCE:]STEP:VOLTage[:AC]:FINal#
Description	Voltage phase A, OPT: Voltage phase B, OPT: Voltage phase C, OPT This command sets the final STEP voltage for selected phase # or for all phases if phase reference is omitted.
Parameters	Voltage , < NORmal SATurate > Default is NORmal if optional second parameter is omitted.
Parameter Format	<nr2>, <cr>
Example	STEP:VOLT:FIN 180.00, SAT
Query Format	[SOURCE:]STEP:VOLTage[:AC]:FINal#?
Returned Data Format	<nr2> <nr2>,<nr2>,<nr2>
Query Example	STEP:VOLT:FIN? 180.000,180.000,180.000

Query Syntax	[SOURCE:]STEP:VOLTage[:AC]:FINal#:MINimum?
Description	This command returns the minimum permissible set value for the final STEP voltage for selected phase # or for all phases if phase reference is omitted
Returned Data Format	<nr2>
Query Example	STEP:VOLT:FIN1:MIN? Query return values for MINimum, MAXimum and DEFault are dependent on MODE and interdependent parameter value settings
Query Syntax	[SOURCE:]STEP:VOLTage[:AC]:FINal#:MAXimum?
Description	This command returns the maximum permissible set value for the final STEP voltage for selected phase # or for all phases if phase reference is omitted
Returned Data Format	<nr2>
Query Example	STEP:VOLT:FIN1:MAX? Query return values for MINimum, MAXimum and DEFault are dependent on MODE and interdependent parameter value settings
Query Syntax	[SOURCE:]STEP:VOLTage[:AC]:FINal#:DEFault?
Description	This command returns the default set value for the final STEP voltage for selected phase # or for all phases if phase reference is omitted
Returned Data Format	<nr2>
Query Example	STEP:VOLT:FIN1:DEF? Query return values for MINimum, MAXimum and DEFault are dependent on MODE and interdependent parameter value settings
Command Syntax	[SOURCE:]STEP:VOLTage[:AC]:DELTA# < nr2 >, <cr> [SOURCE:]STEP:VOLTage[:AC]:DELTA#
Description	Voltage phase A, OPT: Voltage phase B, OPT: Voltage phase C, OPT This command sets the delta STEP voltage for selected phase # or for all phases if phase reference is omitted.
Parameters	Voltage , < NORmal SATurate > Default is NORmal if optional second parameter is omitted.
Parameter Format	<nr2>, <cr>
Example	STEP:VOLT:DELT1 10.00, SAT
Query Format	[SOURCE:]STEP:VOLTage[:AC]:DELTA#?
Returned Data Format	<nr2> <nr2>,<nr2>,<nr2>
Query Example	STEP:VOLT:DELT? 10.000,10.000,10.000

Query Syntax	[SOURCE:]STEP:VOLTage[:AC]:DELTA#:MINimum?
Description	This command returns the minimum permissible set value for the delta STEP voltage for selected phase # or for all phases if phase reference is omitted
Returned Data Format	<nr2>
Query Example	STEP:VOLT:DELT1:MIN? Query return values for MINimum, MAXimum and DEFault are dependent on MODE and interdependent parameter value settings
Query Syntax	[SOURCE:]STEP:VOLTage[:AC]:DELTA#:MAXimum?
Description	This command returns the maximum permissible set value for the delta STEP voltage for selected phase # or for all phases if phase reference is omitted
Returned Data Format	<nr2>
Query Example	STEP:VOLT:DELT1:MAX? Query return values for MINimum, MAXimum and DEFault are dependent on MODE and interdependent parameter value settings
Query Syntax	[SOURCE:]STEP:VOLTage[:AC]:DELTA#:DEFault?
Description	This command returns the default set value for the delta STEP voltage for selected phase # or for all phases if phase reference is omitted
Returned Data Format	<nr2>
Query Example	STEP:VOLT:DELT1:DEF? Query return values for MINimum, MAXimum and DEFault are dependent on MODE and interdependent parameter value settings
Command Syntax	[SOURCE:]STEP:VOLTage:DC[:INITial]# < nr2 >, <cr> [SOURCE:]STEP:VOLTage:DC[:INITial]#
Description	Voltage phase A, OPT: Voltage phase B, OPT: Voltage phase C, OPT This command sets the initial STEP DC voltage for selected phase # or for all phases if phase reference is omitted.
Parameters	Voltage , < NORmal SATurate > Default is NORmal if optional second parameter is omitted.
Parameter Format	<nr2>, <cr>
Example	STEP:VOLT:DC1 230.00, SAT
Query Format	[SOURCE:]STEP:VOLTage:DC[:INITial]#?
Returned Data Format	<nr2> <nr2>,<nr2>,<nr2>
Query Example	STEP:VOLT:DC? 0.000,0.000,0.000

Query Syntax	[SOURCE:]STEP:VOLTage:DC[:INITial]#:MINimum?
Description	This command returns the minimum permissible set value for the initial STEP DC voltage for selected phase # or for all phases if phase reference is omitted
Returned Data Format	<nr2>
Query Example	STEP:VOLT:DC1:MIN? Query return values for MINimum, MAXimum and DEFault are dependent on MODE and interdependent parameter value settings
Query Syntax	[SOURCE:]STEP:VOLTage:DC[:INITial]#:MAXimum?
Description	This command returns the maximum permissible set value for the initial STEP DC voltage for selected phase # or for all phases if phase reference is omitted
Returned Data Format	<nr2>
Query Example	STEP:VOLT:DC1:MAX? Query return values for MINimum, MAXimum and DEFault are dependent on MODE and interdependent parameter value settings
Query Syntax	[SOURCE:]STEP:VOLTage:DC[:INITial]#:DEFault?
Description	This command returns the default set value for the initial STEP DC voltage for selected phase # or for all phases if phase reference is omitted
Returned Data Format	<nr2>
Query Example	STEP:VOLT:DC1:DEF? Query return values for MINimum, MAXimum and DEFault are dependent on MODE and interdependent parameter value settings
Command Syntax	[SOURCE:]STEP:VOLTage:DC:FINal# < nr2 >, <cr> [SOURCE:]STEP:VOLTage:DC:FINal#
Description	Voltage phase A, OPT: Voltage phase B, OPT: Voltage phase C, OPT This command sets the final STEP DC voltage for selected phase # or for all phases if phase reference is omitted.
Parameters	Voltage , < NORmal SATurate > Default is NORmal if optional second parameter is omitted.
Parameter Format	<nr2>, <cr>
Example	STEP:VOLT:DC:FIN 187.00, SAT
Query Format	[SOURCE:]STEP:VOLTage:DC:FINal#?
Returned Data Format	<nr2> <nr2>,<nr2>,<nr2>
Query Example	STEP:VOLT:DC:FIN? 187.000,187.000,187.000

Query Syntax	[SOURCE:]STEP:VOLTage:DC:FINal#:MINimum?
Description	This command returns the minimum permissible set value for the final STEP DC voltage for selected phase # or for all phases if phase reference is omitted
Returned Data Format	<nr2>
Query Example	STEP:VOLT:DC:FIN1:MIN? Query return values for MINimum, MAXimum and DEFault are dependent on MODE and interdependent parameter value settings
Query Syntax	[SOURCE:]STEP:VOLTage:DC:FINal#:MAXimum?
Description	This command returns the maximum permissible set value for the final STEP DC voltage for selected phase # or for all phases if phase reference is omitted
Returned Data Format	<nr2>
Query Example	STEP:VOLT:DC:FIN1:MAX? Query return values for MINimum, MAXimum and DEFault are dependent on MODE and interdependent parameter value settings
Query Syntax	[SOURCE:]STEP:VOLTage:DC:FINal#:DEFault?
Description	This command returns the default set value for the final STEP DC voltage for selected phase # or for all phases if phase reference is omitted
Returned Data Format	<nr2>
Query Example	STEP:VOLT:DC:FIN1:DEF? Query return values for MINimum, MAXimum and DEFault are dependent on MODE and interdependent parameter value settings
Command Syntax	[SOURCE:]STEP:VOLTage:DC:DELTA# < nr2 >, <cr> [SOURCE:]STEP:VOLTage:DC:DELTA#
Description	Voltage phase A, OPT: Voltage phase B, OPT: Voltage phase C, OPT This command sets the delta STEP DC voltage for selected phase # or for all phases if phase reference is omitted.
Parameters	Voltage , < NORmal SATurate > Default is NORmal if optional second parameter is omitted.
Parameter Format	<nr2>, <cr>
Example	STEP:VOLT:DC:DELT1 10.00, SAT
Query Format	[SOURCE:]STEP:VOLTage:DC:DELTA#?
Returned Data Format	<nr2> <nr2>,<nr2>,<nr2>
Query Example	STEP:VOLT:DC:DELT? 10.0000

<p>Query Syntax Description</p>	<p>[SOURCE:]STEP:VOLTage:DC:DELTA#:MINimum? This command returns the minimum permissible set value for the delta STEP DC voltage for selected phase # or for all phases if phase reference is omitted</p>
<p>Returned Data Format Query Example</p>	<p><nr2> STEP:VOLT:DC:DELTA1:MIN? Query return values for MINimum, MAXimum and DEFault are dependent on MODE and interdependent parameter value settings</p>
<p>Query Syntax Description</p>	<p>[SOURCE:]STEP:VOLTage:DC:DELTA#:MAXimum? This command returns the maximum permissible set value for the delta STEP DC voltage for selected phase # or for all phases if phase reference is omitted</p>
<p>Returned Data Format Query Example</p>	<p><nr2> STEP:VOLT:DC:DELTA1:MAX? Query return values for MINimum, MAXimum and DEFault are dependent on MODE and interdependent parameter value settings</p>
<p>Query Syntax Description</p>	<p>[SOURCE:]STEP:VOLTage:DC:DELTA#:DEFault? This command returns the default set value for the delta STEP DC voltage for selected phase # or for all phases if phase reference is omitted</p>
<p>Returned Data Format Query Example</p>	<p><nr2> STEP:VOLT:DC:DELTA1:DEF? Query return values for MINimum, MAXimum and DEFault are dependent on MODE and interdependent parameter value settings</p>
<p>Command Syntax Description Parameters</p>	<p>[SOURCE:]STEP:FREQUENCY[:INITIAL] <nr2 >, <cr> This command sets the initial STEP frequency. Frequency, < NORMal SATurate > Default is NORMal if optional second parameter is omitted.</p>
<p>Parameter Format Example</p>	<p><nr2>, <cr> STEP:FREQ 50.0, SAT</p>
<p>Query Format Returned Data Format Query Example</p>	<p>[SOURCE:]STEP:FREQUENCY[:INITIAL]? <nr2> STEP:FREQ? 50.0000</p>
<p>Query Syntax Description</p>	<p>[SOURCE:]STEP:FREQUENCY[:INITIAL]:MINimum? This command returns the minimum permissible set value for the initial STEP frequency.</p>
<p>Returned Data Format Query Example</p>	<p><nr2> STEP:FREQ:MIN? Query return values for MINimum, MAXimum and DEFault are dependent on MODE and interdependent parameter value settings</p>

<p>Query Syntax Description</p> <p>Returned Data Format Query Example</p>	<p>[SOURCE:]STEP:FREQUENCY[:INITIAL]:MAXIMUM? This command returns the maximum permissible set value for the initial STEP frequency.</p> <p><nr2> STEP:FREQ:MAX? Query return values for MINimum, MAXimum and DEFault are dependent on MODE and interdependent parameter value settings</p>
<p>Query Syntax Description</p> <p>Returned Data Format Query Example</p>	<p>[SOURCE:]STEP:FREQUENCY[:INITIAL]:DEFAULT? This command returns the default set value for the initial STEP frequency.</p> <p><nr2> STEP:FREQ:DEF? Query return values for MINimum, MAXimum and DEFault are dependent on MODE and interdependent parameter value settings</p>
<p>Command Syntax Description Parameters</p> <p>Parameter Format Example</p> <p>Query Format Returned Data Format Query Example</p>	<p>[SOURCE:]STEP:FREQUENCY:FINAL <nr2 >, <cr> This command sets the final STEP frequency. Frequency, < NORMAL SATurate > Default is NORMAL if optional second parameter is omitted.</p> <p><nr2>, <cr> STEP:FREQ:FIN 55.0, SAT</p> <p>[SOURCE:]STEP:FREQUENCY:FINAL? <nr2> STEP:FREQ:FIN? 55.0000</p>
<p>Query Syntax Description</p> <p>Returned Data Format Query Example</p>	<p>[SOURCE:]STEP:FREQUENCY:FINAL:MINIMUM? This command returns the minimum permissible set value for the final STEP frequency.</p> <p><nr2> STEP:FREQ:FIN:MIN? 15.0000</p>
<p>Query Syntax Description</p> <p>Returned Data Format Query Example</p>	<p>[SOURCE:]STEP:FREQUENCY:FINAL:MAXIMUM? This command returns the maximum permissible set value for the final STEP frequency.</p> <p><nr2> STEP:FREQ:FIN:MAX? 1200.0000</p>

<p>Query Syntax Description</p> <p>Returned Data Format Query Example</p>	<p>[SOURCE:]STEP:FREQUENCY:FINAL:DEFAULT? This command returns the default set value for the final STEP frequency.</p> <p><nr2> STEP:FREQ:FIN:DEF? 60.0000</p>
<p>Command Syntax Description Parameters</p> <p>Parameter Format Example Query Format Returned Data Format Query Example</p>	<p>[SOURCE:]STEP:FREQUENCY:DELTA <nr2 >, <cr> This command sets the delta frequency. Frequency, < NORMAL SATURATE > Default is NORMAL if optional second parameter is omitted.</p> <p><nr2>, <cr> STEP:FREQ:DELT 5.0, SAT</p> <p>[SOURCE:]STEP:FREQUENCY:DELTA? <nr2> STEP:FREQ:DELT? 5.0000</p>
<p>Query Syntax Description</p> <p>Returned Data Format Query Example</p>	<p>[SOURCE:]STEP:FREQUENCY:DELTA:MINIMUM? This command returns the minimum permissible set value for the delta STEP frequency.</p> <p><nr2> STEP:FREQ:DELT:MIN? Query return values for MINIMUM, MAXIMUM and DEFAULT are dependent on MODE and interdependent parameter value settings</p>
<p>Query Syntax Description</p> <p>Returned Data Format Query Example</p>	<p>[SOURCE:]STEP:FREQUENCY:DELTA:MAXIMUM? This command returns the maximum permissible set value for the delta STEP frequency.</p> <p><nr2> STEP:FREQ:DELT:MAX? Query return values for MINIMUM, MAXIMUM and DEFAULT are dependent on MODE and interdependent parameter value settings</p>
<p>Query Syntax Description</p> <p>Returned Data Format Query Example</p>	<p>[SOURCE:]STEP:FREQUENCY:DELTA:DEFAULT? This command returns the default set value for the delta STEP frequency.</p> <p><nr2> STEP:FREQ:DELT:DEF? Query return values for MINIMUM, MAXIMUM and DEFAULT are dependent on MODE and interdependent parameter value settings</p>

Command Syntax	[SOURCE:]STEP:WAVEFORM# <nr1 >
Description	This command sets the selected waveform using the waveform number.
Parameters	Waveform number
Parameter Format	<nr1>, <cr>
Example	STEP:WAVEFORM 1
Query Format	[SOURCE:]STEP:WAVEFORM#?
Returned Data Format	<nr1>
Query Example	STEP:WAVEFORM#? 1.0000
Query Syntax	[SOURCE:]STEP:WAVEFORM#:MINimum?
Description	This command returns the minimum permissible set value for the STEP waveform.
Returned Data Format	<nr1>
Query Example	STEP:WAVEFORM#:MIN? 1
Query Syntax	[SOURCE:]STEP:WAVEFORM#:MAXimum?
Description	This command returns the maximum permissible set value for the STEP waveform.
Returned Data Format	<nr1>
Query Example	STEP:WAVEFORM#:MAX? 200
Query Syntax	[SOURCE:]STEP:WAVEFORM:DEFault?
Description	This command returns the default set value for the STEP waveform.
Returned Data Format	<nr1>
Query Example	STEP:WAVEFORM:DEF? 1
Command Syntax	[SOURCE:]STEP:PHASE[:INITial]# < nr2 >, <cr>
Description	This command sets the initial STEP phase angle for selected phase # number. Only phase 1 (B) and 2 (C) are allowed.
Parameters	Phase No., < NORmal SATurate > Default is NORmal if optional second parameter is omitted.
Parameter Format	<nr1>, <cr>
Example	STEP:PHAS1 245.0
Query Format	[SOURCE:]STEP:PHASE[:INITial]#?
Returned Data Format	<nr1>, <cr>
Query Example	STEP:PHAS1? 245.0000

Query Syntax	[SOURCE:]STEP:PHASE[:INITIAL]#:MINIMUM?
Description	This command returns the minimum permissible set value of the initial STEP phase angle for selected phase #
Returned Data Format	<nr1>
Query Example	STEP:PHAS1:MIN? Query return values for MINimum, MAXimum and DEFault are dependent on MODE and interdependent parameter value settings
Query Syntax	[SOURCE:]STEP:PHASE[:INITIAL]#:MAXIMUM?
Description	This command returns the maximum permissible set value of the initial STEP phase angle for selected phase #
Returned Data Format	<nr1>
Query Example	STEP:PHAS1:MAX? Query return values for MINimum, MAXimum and DEFault are dependent on MODE and interdependent parameter value settings
Query Syntax	[SOURCE:]STEP:PHASE[:INITIAL]#:DEF?
Description	This command returns the default set value of the initial STEP phase angle for selected phase #
Returned Data Format	<nr1>
Query Example	Query return values for MINimum, MAXimum and DEFault are dependent on MODE and interdependent parameter value settings
Command Syntax	[SOURCE:]STEP:PHASE:FINAL# < nr2 >, <cr>
Description	This command sets the final STEP phase angle for selected phase # number. Only phase 1 (B) and 2 (C) are allowed.
Parameters	Phase No., < NORMAL SATurate > Default is NORMAL if optional second parameter is omitted.
Parameter Format	<nr2>, <cr>
Example	STEP:PHAS:FIN1 240.0
Query Format	[SOURCE:]STEP:PHASE:FINAL#?
Returned Data Format	<nr2>
Query Example	STEP:PHAS:FIN1? 240.0000
Query Syntax	[SOURCE:]STEP:PHASE:FINAL#:MINIMUM?
Description	This command returns the minimum permissible set value of the final STEP phase angle for selected phase #
Returned Data Format	<nr1>
Query Example	STEP:PHAS:FIN1:MIN? Query return values for MINimum, MAXimum and DEFault are dependent on MODE and interdependent parameter value settings

<p>Query Syntax Description</p> <p>Returned Data Format Query Example</p>	<p>[SOURCE:]STEP:PHASE:FINal#:MAXimum?</p> <p>This command returns the maximum permissible set value of the final STEP phase angle for selected phase #</p> <p><nr1></p> <p>STEP:PHAS:FIN1:MAX?</p> <p>Query return values for MINimum, MAXimum and DEFault are dependent on MODE and interdependent parameter value settings</p>
<p>Query Syntax Description</p> <p>Returned Data Format Query Example</p>	<p>[SOURCE:]STEP:PHASE:FINal#:DEF?</p> <p>This command returns the default set value of the final STEP phase angle for selected phase #</p> <p><nr1></p> <p>STEP:PHAS:FIN1:DEF?</p> <p>Query return values for MINimum, MAXimum and DEFault are dependent on MODE and interdependent parameter value settings</p>
<p>Command Syntax Description</p> <p>Parameters</p> <p>Parameter Format Example</p> <p>Query Format</p> <p>Returned Data Format Query Example</p>	<p>[SOURCE:]STEP:PHASE:DELTA# < nr2 >, <cr></p> <p>This command sets the delta STEP phase angle for selected phase # number. Only phase 1 (B) and 2 (C) are allowed.</p> <p>Phase No., < NORmal SATurate ></p> <p>Default is NORmal if optional second parameter is omitted.</p> <p><nr1>, <cr></p> <p>STEP:PHAS:DELT1 240.0</p> <p>[SOURCE:]STEP:PHASE:DELTA#?</p> <p><nr1>, <cr></p> <p>STEP:PHAS:DELT1?</p> <p>240.0000</p>
<p>Query Syntax Description</p> <p>Returned Data Format Query Example</p>	<p>[SOURCE:]STEP:PHASE:DELTA#:MINimum?</p> <p>This command returns the minimum permissible set value of the delta STEP phase angle for selected phase #</p> <p><nr1></p> <p>STEP:PHAS:DELT1:MIN?</p> <p>Query return values for MINimum, MAXimum and DEFault are dependent on MODE and interdependent parameter value settings</p>
<p>Query Syntax Description</p> <p>Returned Data Format Query Example</p>	<p>[SOURCE:]STEP:PHASE:DELTA#:MAXimum?</p> <p>This command returns the maximum permissible set value of the delta STEP phase angle for selected phase #</p> <p><nr1></p> <p>STEP:PHAS:DELT1:MAX?</p> <p>Query return values for MINimum, MAXimum and DEFault are dependent on MODE and interdependent parameter value settings</p>

Query Syntax	[SOURCE:]STEP:PHASE:DELTA#:DEF?
Description	This command returns the default set value of the delta STEP phase angle for selected phase #
Returned Data Format	<nr1>
Query Example	Query return values for MINimum, MAXimum and DEFault are dependent on MODE and interdependent parameter value settings
Command Syntax	[SOURCE:]STEP <cr> >>> <i>Alias for PROGRAM:TRANSient command.</i> <<<
Description	This command controls step transient execution
Parameters	< RUN STOP PAUSE STEP RESTart >
Parameter Format	<cr>
Example	STEP RUN
Query Format	[SOURCE:]STEP?
Description	Query format returns the step transient execution state as either RUN, STOP, PAUS, STEP or REST
Returned Data Format	<nr1> Return values represent running state as follows:
	0 Stopped
	1 Running
	2 Paused
	3 Stepping
	4 Waiting for trigger
Query Example	STEP? 1
Command Syntax	[SOURCE:]STEP:LOAD
Description	This command converts the step transient definition to the power source's regular transient segment format and loads it in the controller real-time memory for execution.
Parameters	None
Parameter Format	n/a
Example	STEP RUN
Query Format	[SOURCE:]STEP:LOAD?
Description	Query format returns a 1 if the step transient load operation was successful, otherwise returns 0.
Returned Data Format	<nr1> Return values represent:
	0 Load Failed
	1 Load completed
Query Example	STEP? 1

Query Syntax	[SOURCE:]STEP:PROGRESS? >>> <i>Alias for PROGRAM:TRANSIENT:PROGRESS command.</i> <<<
Description	This query command returns the status of the step being executed.
Parameters	None
Parameter Format	n/a
Description	Query returns the step transient execution state as either RUN, STOP, PAUS, STEP or REST
Returned Data Format	<cr> The response is a comma-separated value string representing: PROGRESS, CURRENT SEGMENT PROGRESS, CURRENT SEGMENT, CURRENT SEGMENT TIME, TOTAL TIME, TOTAL SEGMENTS, REPEAT TIME COUNTER
Query Example	STEP:PROG? 1, 45, 2, 1.2300, 2.0000, 4, 5

Query Syntax	[SOURCE:]STEP:CHECK?
Description	This query command returns the result of a check on the programmed step parameters to determine if they are ok to run.
Parameters	None
Parameter Format	n/a
Description	Query returns result of STEP parameters integrity check
Returned Data Format	<cr> The response is either OK or if not, a string containing the error.
Query Example	STEP:PROG? OK

Query Syntax	[SOURCE:]STEP:ALL?
Description	This query command returns a comma-separated values string of the entire step parameters, settings, and limits. Each set value is preceded by a tag identifying the parameter. This same data structure is used for front panel display and by the web server. The advantage is that this commands returns all step related information using just one query command.

Parameters	None
Parameter Format	n/a
Description	Returns complete STEP setup as a comma separated value string.
Returned Data Format	<cr>
Query Example	STEP:ALL?

form,3,loaded,0,status,0,progress,0,current element progress,0,current element,0,current element time,0,total time,0,total elements,0,repeat times,0,hold,1,init,1,mode,0,mode max,2,mode min,0,dwell,0,dwell max,10000,dwell min,0,ramp,0,ramp max,10000,ramp min,0,length,0,length max,10000,length min,0,repeat,1,repeat max,65535,repeat min,0,count,10,count max,200,count min,1,count min reason,0,count max reason,0,waveform all,1,waveform all exist,1,waveform a,1,waveform a exist,1,waveform b,1,waveform b exist,1,waveform c,1,waveform c exist,1,waveform max,200,waveform min,1,initial frequency,0.0000,initial frequency min,0.0000,initial frequency max,0.0000,initial frequency min reason,4,initial frequency max reason,4,initial voltage ac all,0.0000,initial voltage ac all max,0.0000,initial voltage ac all min,0.0000,initial voltage ac all max reason,4,initial voltage ac all min reason,4,initial voltage ac a,0.0000,initial voltage ac a max,0.0000,initial voltage ac a min,0.0000,initial voltage ac a max reason,4,initial voltage ac a min reason,4,initial voltage ac b,0.0000,initial voltage ac b max,0.0000,initial voltage ac b min,0.0000,initial voltage ac b max reason,4,initial voltage ac b min reason,4,initial voltage ac c,0.0000,initial voltage ac c max,0.0000,initial voltage ac c min,0.0000,initial voltage ac c max reason,4,initial voltage ac c min reason,4,initial voltage dc all,0.0000,initial voltage dc all max,425.0000,initial voltage dc all min,-425.0000,initial voltage dc all max reason,0,initial voltage dc all min reason,0,initial voltage dc a,0.0000,initial voltage dc a max,425.0000,initial voltage dc a min,-425.0000,initial voltage dc a max reason,0,initial voltage dc a min reason,0,initial voltage dc b,0.0000,initial

voltage dc b max,425.0000,initial voltage dc b min,-425.0000,initial voltage dc b max reason,0,initial voltage dc b min reason,0,initial voltage dc c,0.0000,initial voltage dc c max,425.0000,initial voltage dc c min,-425.0000,initial voltage dc c max reason,0,initial voltage dc c min reason,0,initial phase b,120.0000,initial phase c,240.0000,initial phase max,99999.0000,initial phase min,-99999.0000,final frequency,0.0000,final frequency min,0.0000,final frequency max,0.0000,final frequency min reason,4,final frequency max reason,4,final voltage ac all,0.0000,final voltage ac all max,0.0000,final voltage ac all min,0.0000,final voltage ac all max reason,4,final voltage ac all min reason,4,final voltage ac a,0.0000,final voltage ac a max,0.0000,final voltage ac a min,0.0000,final voltage ac a max reason,4,final voltage ac a min reason,4,final voltage ac b,0.0000,final voltage ac b max,0.0000,final voltage ac b min,0.0000,final voltage ac b max reason,4,final voltage ac b min reason,4,final voltage ac c,0.0000,final voltage ac c max,0.0000,final voltage ac c min,0.0000,final voltage ac c max reason,4,final voltage ac c min reason,4,final voltage dc all,0.0000,final voltage dc all max,425.0000,final voltage dc all min,-425.0000,final voltage dc all max reason,0,final voltage dc all min reason,0,final voltage dc a,0.0000,final voltage dc a max,425.0000,final voltage dc a min,-425.0000,final voltage dc a max reason,0,final voltage dc a min reason,0,final voltage dc b,0.0000,final voltage dc b max,425.0000,final voltage dc b min,-425.0000,final voltage dc b max reason,0,final voltage dc b min reason,0,final voltage dc c,0.0000,final voltage dc c max,425.0000,final voltage dc c min,-425.0000,final voltage dc c max reason,0,final voltage dc c min reason,0,final phase b,120.0000,final phase c,240.0000,final phase max,99999.0000,final phase min,-99999.0000,delta frequency,0.0000,delta frequency min,0.0000,delta frequency max,0.0000,delta frequency min reason,4,delta frequency max reason,4,delta voltage ac all,0.0000,delta voltage ac all max,0.0000,delta voltage ac all min,0.0000,delta voltage ac all max reason,4,delta voltage ac all min reason,4,delta voltage ac a,0.0000,delta voltage ac a max,0.0000,delta voltage ac a min,0.0000,delta voltage ac a max reason,4,delta voltage ac a min reason,4,delta voltage ac b,0.0000,delta voltage ac b max,0.0000,delta voltage ac b min,0.0000,delta voltage ac b max reason,4,delta voltage ac b min reason,4,delta voltage ac c,0.0000,delta voltage ac c max,0.0000,delta voltage ac c min,0.0000,delta voltage ac c max reason,4,delta voltage ac c min reason,4,delta voltage dc all,0.0000,delta voltage dc all max,42.5000,delta voltage dc all min,-42.5000,delta voltage dc all max reason,0,delta voltage dc all min reason,0,delta voltage dc a,0.0000,delta voltage dc a max,42.5000,delta voltage dc a min,-42.5000,delta voltage dc a max reason,0,delta voltage dc a min reason,0,delta voltage dc b,0.0000,delta voltage dc b max,42.5000,delta voltage dc b min,-42.5000,delta voltage dc b max reason,0,delta voltage dc b min reason,0,delta voltage dc c,0.0000,delta voltage dc c max,42.5000,delta voltage dc c min,-42.5000,delta voltage dc c max reason,0,delta voltage dc c min reason,0,delta phase b,0.0000,delta phase c,0.0000,delta phase max,99999.0000,delta phase min,-99999.0000

8.7.13 PULSE Transient Commands

The command in this section control PULSE transients. Some of these commands have the option to specify NORMAL or SATurate.

SATurate mode: If a dwell time setting is out of limits, the dwell time will saturate to the limit min/max and it will not trip an error.

NORMAL mode: If a dwell time setting is out of limits, an error will be generated and the dwell time setting will not be modified.

Command Syntax	[SOURCE:]PULSE:COUNT <nr1>, <opt>
Description	This command sets the pulse count or the number of pulses to execute. Minimum time set value allowed is 1.
Parameters	Count, Option: < NORMAL SATurate > Default is NORMAL if optional second parameter is omitted.
Parameter Format	<nr1>, <cr>
Example	PULSE:COUNT 5
Query Format	[SOURCE:]PULSE:COUNT?
Returned Data Format	<nr1>
Query Example	PULSE:COUNT? 5.0000

Query Syntax	[SOURCE:]PULSE:COUNT:MINimum?
Description	This command returns the minimum permissible set value for the PULSE count.
Returned Data Format	<nr1>
Query Example	PULS:COUNT:MIN? 0
Query Syntax	[SOURCE:]PULSE:COUNT:MAXimum?
Description	This command returns the maximum permissible set value for the PULSE count.
Returned Data Format	<nr1>
Query Example	PULS:COUNT:MAX? 65535
Query Syntax	[SOURCE:]PULSE:COUNT:DEFault?
Description	This command returns the default set value for the PULSE count.
Returned Data Format	<nr1>
Query Example	PULS:COUNT:DEF? 1
Command Syntax	[SOURCE:]PULSE:DCYcle <nr1>, <opt>
Description	This command sets the pulse duty cycle in percent. Minimum set value allowed is 1, max is 99.
Parameters	Duty Cycle %, Option: < NORmal SATurate > Default is NORmal if optional second parameter is omitted.
Parameter Format	<nr1>, <cr>
Example	PULS:DCYC 50
Query Format	[SOURCE:]PULSE:DCYcle?
Returned Data Format	<nr1>
Query Example	PULS:DCYC? 50.0000
Query Syntax	[SOURCE:]PULSE:DCYcle:MINimum?
Description	This command returns the minimum permissible set value for the PULSE duty cycle.
Returned Data Format	<nr2>
Query Example	PULS:DCYC:MIN? 0.0000
Query Syntax	[SOURCE:]PULSE:DCYcle:MAXimum?
Description	This command returns the maximum permissible set value for the PULSE duty cycle.
Returned Data Format	<nr2>
Query Example	PULS:DCYC:MAX? 100.0000

Query Syntax	[SOURCE:]PULSE:DCYCLE:DEFAULT?
Description	This command returns the default set value for the PULSE duty cycle.
Returned Data Format	<nr2>
Query Example	PULS:DCYC:DEF? 50.0000
Command Syntax	[SOURCE:]PULSE:PERIOD <nr2>, <opt>
Description	This command sets the pulse period in seconds.
Parameters	Period, Option: < NORmal SATurate > Default is NORmal if optional second parameter is omitted.
Parameter Format	<nr2>, <cr>
Example	PULS:PER 12.8
Query Format	[SOURCE:]PULSE:PERIOD?
Returned Data Format	<nr2>
Query Example	PULS:PER? 12.8000
Query Syntax	[SOURCE:]PULSE:PERIOD:MINIMUM?
Description	This command returns the minimum permissible set value for the PULSE period setting.
Returned Data Format	<nr2>
Query Example	PULS:PER:MIN? Query return values for MINimum, MAXimum and DEFault are dependent on MODE and interdependent parameter value settings
Query Syntax	[SOURCE:]PULSE:PERIOD:MAXIMUM?
Description	This command returns the maximum permissible set value for the PULSE period.
Returned Data Format	<nr2>
Query Example	PULS:PER:MAX? Query return values for MINimum, MAXimum and DEFault are dependent on MODE and interdependent parameter value settings
Query Syntax	[SOURCE:]PULSE:PERIOD:DEFAULT?
Description	This command returns the default set value for the PULSE period.
Returned Data Format	<nr2>
Query Example	PULS:PER:DEF? Query return values for MINimum, MAXimum and DEFault are dependent on MODE and interdependent parameter value settings

Command Syntax	[SOURCE:]PULSE:WIDTH <nr2>, <opt>
Description	This command sets the pulse width in seconds.
Parameters	Width, Option: < NORmal SATurate > Default is NORmal if optional second parameter is omitted.
Parameter Format	<nr2>, <cr>
Example	PULS:WIDT 25.6
Query Format	[SOURCE:]PULSE:WIDTH?
Returned Data Format	<nr2>
Query Example	PULS:WIDT? 25.6000
Query Syntax	[SOURCE:]PULSE:WIDTH:MINimum?
Description	This command returns the minimum permissible set value for the PULSE width.
Returned Data Format	<nr2>
Query Example	PULS:WIDT:MIN? Query return values for MINimum, MAXimum and DEFault are dependent on MODE and interdependent parameter value settings
Query Syntax	[SOURCE:]PULSE:WIDTH:MAXimum?
Description	This command the returns maximum permissible set value for the PULSE width.
Returned Data Format	<nr2>
Query Example	PULS:WIDT:MAX? Query return values for MINimum, MAXimum and DEFault are dependent on MODE and interdependent parameter value settings
Query Syntax	[SOURCE:]PULSE:WIDTH:DEFault?
Description	This command returns the default set value for the PULSE width.
Returned Data Format	<nr2>
Query Example	PULS:WIDT:DEF? Query return values for MINimum, MAXimum and DEFault are dependent on MODE and interdependent parameter value settings
Command Syntax	[SOURCE:]PULSE:MODE <nr2>, <opt>
Description	This command sets the pulse width in seconds.
Parameters	< 0 PW 1 PD 2 WD > Encoding: 0 PW program pulse by period and width 1 PD program pulse by period and duty cycle 2 WD program pulse by width and duty cycle
Parameter Format	<nr1> or <cr>
Example	PULS:MODE WD
Query Format	[SOURCE:]PULSE:MODE?
Returned Data Format	<nr1>
Query Example	PULS:MODE? 2

<p>Query Syntax Description</p> <p>Parameters</p> <p>Returned Data Format</p> <p>Query Example</p>	<p>[SOURCE:]PULSE:MODE:CATalog?</p> <p>This command returns the available programming modes: "0,Period and width,1,Period and duty cycle,2,Width and duty cycle".</p> <p>None</p> <p><cr></p> <p>PULS:MODE:CAT?</p> <p>0,Period and width,1,Period and duty cycle,2,Width and duty cycle</p>
<p>Command Syntax</p> <p>Description</p> <p>Parameters</p> <p>Parameter Format</p> <p>Example</p> <p>Query Format</p> <p>Returned Data Format</p> <p>Query Example</p>	<p>[SOURCE:]PULSE:RAMP <nr2>, <opt></p> <p>This command sets the pulse ramp time in seconds.</p> <p>Ramp time, Option: < NORmal SATurate ></p> <p>Default is NORmal if optional second parameter is omitted.</p> <p><nr2>, <cr></p> <p>PULS:RAMP 0.2</p> <p>[SOURCE:]PULSE:RAMP?</p> <p><nr2></p> <p>PULS:RAMP?</p> <p>0.2</p>
<p>Query Syntax</p> <p>Description</p> <p>Returned Data Format</p> <p>Query Example</p>	<p>[SOURCE:]PULSE:RAMP:MINimum?</p> <p>This command returns the minimum permissible set value for the PULSE ramp time.</p> <p><nr2></p> <p>PULS:RAMP:MIN?</p> <p>Query return values for MINimum, MAXimum and DEFault are dependent on MODE and interdependent parameter value settings</p>
<p>Query Syntax</p> <p>Description</p> <p>Returned Data Format</p> <p>Query Example</p>	<p>[SOURCE:]PULSE:RAMP:MAXimum?</p> <p>This command returns the maximum permissible set value for the PULSE ramp time.</p> <p><nr2></p> <p>PULS:RAMP:MAX?</p> <p>Query return values for MINimum, MAXimum and DEFault are dependent on MODE and interdependent parameter value settings</p>
<p>Query Syntax</p> <p>Description</p> <p>Returned Data Format</p> <p>Query Example</p>	<p>[SOURCE:]PULSE:RAMP:DEFault?</p> <p>This command returns the default setting for the PULSE ramp time.</p> <p><nr2></p> <p>PULS:RAMP:DEF?</p> <p>Query return values for MINimum, MAXimum and DEFault are dependent on MODE and interdependent parameter value settings</p>

Command Syntax	[SOURce:]PULSe:VOLTage[:AC]# < nr2 >, <cr> [SOURce:]PULSe:VOLTage[:AC] #
Description	Voltage phase A, OPT: Voltage phase B, OPT: Voltage phase C, OPT This command sets the PULSE voltage for selected phase # or for all phases if phase reference is omitted.
Parameters	Voltage , < NORmal SATurate > Default is NORmal if optional second parameter is omitted.
Parameter Format	<nr2>, <cr>
Example	PULS:VOLT1 230.00, SAT
Query Format	[SOURce:]PULSe:VOLTage[:AC]#?
Returned Data Format	<nr2>
Query Example	PULS:VOLT1? 230.0000
Query Syntax	[SOURce:]PULSe:VOLTage[:AC]#:MINimum?
Description	This command returns the minimum permissible set value for the PULSE voltage for selected phase # or for all phases if phase reference is omitted
Returned Data Format	<nr2>
Query Example	PULS:VOLT1:MIN? 0.0000
Query Syntax	[SOURce:]PULSe:VOLTage[:AC]#:MAXimum?
Description	This command returns the maximum permissible set value for the PULSE voltage for selected phase # or for all phases if phase reference is omitted
Returned Data Format	<nr2>
Query Example	PULS:VOLT:MAX? 300.0000
Query Syntax	[SOURce:]PULSe:VOLTage[:AC]#:DEFault?
Description	This command returns the default set value for the PULSE voltage for selected phase # or for all phases if phase reference is omitted
Returned Data Format	<nr2>
Query Example	PULS:VOLT:DEF? 0.000,0.000,0.000 PULS:VOLT1:DEF? 0.000

Command Syntax	[SOURce:]PULSe:VOLTage:DC# < nr2 >, <cr> [SOURce:]PULSe:VOLTage:DC#
Description	Voltage phase A, OPT: Voltage phase B, OPT: Voltage phase C, OPT This command sets the PULSE DC voltage for selected phase # or for all phases if phase reference is omitted.
Parameters	Voltage , < NORmal SATurate > Default is NORmal if optional second parameter is omitted.
Parameter Format	<nr2>, <cr>
Example	PULS:VOLT:DC1 270.00
Query Format	[SOURce:]PULSe:VOLTage:DC#?
Returned Data Format	<nr2>
Query Example	PULS:VOLT:DC1? 270.0000
Query Syntax	[SOURce:]PULSe:VOLTage:DC#:MINimum?
Description	This command returns the minimum permissible set value for the initial PULSE DC voltage for selected phase # or for all phases if phase reference is omitted
Returned Data Format	<nr2>
Query Example	PULS:VOLT:DC1:MIN? -425.0000
Query Syntax	[SOURce:]PULSe:VOLTage:DC#:MAXimum?
Description	This command returns the maximum permissible set value for the initial PULSE DC voltage for selected phase # or for all phases if phase reference is omitted
Returned Data Format	<nr2>
Query Example	PULS:VOLT:DC1:MAX? 425.0000
Query Syntax	[SOURce:]PULSe:VOLTage:DC#:DEFault?
Description	This command returns the default set value for the initial PULSE voltage for selected phase # or for all phases if phase reference is omitted
Returned Data Format	<nr2>
Query Example	PULS:VOLT:DC1:DEF? 0.000,0.000,0.000

Command Syntax	[SOURCE:]PULSE:FREQUENCY < nr2 >, <cr>
Description	This command sets the PULSE frequency.
Parameters	Voltage , < NORMAL SATurate > Default is NORMAL if optional second parameter is omitted.
Parameter Format	<nr2>, <cr>
Example	PULS:FREQ 50.00
Query Format	[SOURCE:]PULSE:FREQUENCY?
Returned Data Format	<nr2>
Query Example	PULS:FREQ? 60.0000
Query Syntax	[SOURCE:]PULSE:FREQUENCY:MINIMUM?
Description	This command returns the minimum permissible set value for the PULSE frequency.
Returned Data Format	<nr2>
Query Example	PULS:FREQ:MIN? 15.0000
Query Syntax	[SOURCE:]PULSE:FREQUENCY:MAXIMUM?
Description	This command returns the maximum permissible set value for the PULSE frequency.
Returned Data Format	<nr2>
Query Example	PULS:FREQ:MIN? 1200.0000
Query Syntax	[SOURCE:]PULSE:FREQUENCY:DEFAULT?
Description	This command returns the default set value for the initial PULSE frequency.
Returned Data Format	<nr2>
Query Example	PULS:FREQ:DEF? 60.0000
Command Syntax	[SOURCE:]PULSE:WAVEFORM# <nr1 >
Description	This command sets the selected waveform using the waveform number.
Parameters	Waveform number
Parameter Format	<nr1>, <cr>
Example	PULS:WAVEFORM 1
Query Format	[SOURCE:]PULSE:WAVEFORM#?
Returned Data Format	<nr1>
Query Example	PULS:WAVEFORM#? 1.0000

Query Syntax	[SOURCE:]PULSE:WAVEFORM#:MINimum?
Description	This command returns the minimum permissible set value for the PULSE waveform.
Returned Data Format	<nr1>
Query Example	PULS:WAVEFORM#:MIN? 1
Query Syntax	[SOURCE:]PULSE:WAVEFORM#:MAXimum?
Description	This command returns the maximum permissible set value for the PULSE waveform.
Returned Data Format	<nr1>
Query Example	PULS:WAVEFORM#:MAX? 200
Query Syntax	[SOURCE:]PULSE:WAVEFORM:DEFault?
Description	This command returns the default set value for the PULSE waveform.
Returned Data Format	<nr1>
Query Example	PULS:WAVEFORM:DEF? 1
Command Syntax	[SOURCE:]PULSE:PHAS# < nr2 >, <cr>
Description	This command sets the initial PULSE phase angle for selected phase # number. Only phase 2 (B) and 3 (C) are allowed.
Parameters	Phase No., < NORmal SATurate > Default is NORmal if optional second parameter is omitted.
Parameter Format	<nr1>, <cr>
Example	PULS:PHAS1 245.0
Query Format	[SOURCE:]PULSE:PHAS#?
Returned Data Format	<nr1>, <cr>
Query Example	PULS:PHAS1? 245.0000
Query Syntax	[SOURCE:]PULSE:PHAS#:MINimum?
Description	This command returns the minimum permissible set value of the initial PULSE phase angle for selected phase #
Returned Data Format	<nr1>
Query Example	PULS:PHAS1:MIN? 0.0000
Query Syntax	[SOURCE:]PULSE:PHAS#:MAXimum?
Description	This command returns the maximum permissible set value of the initial PULSE phase angle for selected phase #
Returned Data Format	<nr1>
Query Example	PULS:PHAS1:MAX? 360.000

Query Syntax	[SOURCE:]PULSE:PHASE#:DEF?
Description	This command returns the default set value of the initial PULSE phase angle for selected phase #
Returned Data Format	<nr1>
Query Example	PULS:PHAS2:DEF? 120.0000 PULS:PHAS3:DEF? 240.0000
Command Syntax	[SOURCE:]PULSE <cr>
Description	>>> <i>Alias for PROGRAM:TRANSient command.</i> <<<
Parameters	< RUN STOP PAUSE STEP RESTart >
Parameter Format	<cr>
Example	PULS RUN
Query Format	[SOURCE:]PULSE?
Description	Query format returns the pulse transient execution state as either RUN, STOP, PAUS, STEP or REST
Returned Data Format	<nr1> Return values represent running state as follows: 0 Stopped 1 Running 2 Paused 3 Stepping 4 Waiting for trigger
Query Example	PULS? 1
Command Syntax	[SOURCE:]PULSE:LOAD
Description	This command converts the pulse transient definition to the power source's regular transient segment format and loads it in the controller real-time memory for execution.
Parameters	None
Parameter Format	n/a
Example	STEP RUN
Query Format	[SOURCE:]PULSE:LOAD?
Description	Query format returns a 1 if the pulse transient load operation was successful, otherwise returns 0.
Returned Data Format	<nr1> Return values represent: 0 Load Failed 1 Load completed
Query Example	STEP? 1

Query Syntax	[SOURCE:]PULSE:PROGRESS?
Description	>>> <i>Alias for PROGRAM:TRANSient:PROGress command.</i> <<<
Parameters	None
Parameter Format	n/a
Description	Query returns the step transient execution state as either RUN, STOP, PAUS, STEP or REST
Returned Data Format	<cr> The response is a comma-separated value string representing: PROGRESS, CURRENT SEGMENT PROGRESS, CURRENT SEGMENT, CURRENT SEGMENT TIME, TOTAL TIME, TOTAL SEGMENTS, REPEAT TIME COUNTER
Query Example	PULS:PROG? 1, 45, 2, 1.2300, 2.0000, 4, 5
Query Syntax	[SOURCE:]PULSE:CHECK?
Description	This query command returns the result of a check on the programmed pulse parameters to determine if they are ok to run.
Parameters	None
Parameter Format	n/a
Description	Query returns result of PULSE parameters integrity check
Returned Data Format	<cr> The response is either OK or if not, a string containing the error.
Query Example	PULS:PROG? OK
Query Syntax	[SOURCE:]PULSE:ALL?
Description	This query command returns a comma-separated values string of the entire pulse parameters, settings, and limits. Each set value is preceded by a tag identifying the parameter. This same data structure is used for front panel display and by the web server. The advantage is that this commands returns all pulse related information using just one query command.
Parameters	None
Parameter Format	n/a
Description	Returns complete PULSE setup as a comma separated value string.
Returned Data Format	<cr>
Query Example	PULS:ALL? form,3,loaded,0,status,0,progress,0,current element progress,0,current element,0,current element time,0,total time,0,total elements,0,repeat times,0,count,1,count max,65535,count min,0,dcycle,50.0000,dcycle max,100.0000,dcycle max,0.0000,period,0,period max,50000,period min,0,width,0,width max,50000,width min,0,ramp,0,ramp max,0,ramp min,0,mode,0,mode max,2,mode min,0,frequency,60.000,frequency min,15.000,frequency max,1200.000,frequency min reason,1,frequency max reason,2,waveform all,1,waveform all exist,1,waveform a,1,waveform a exist,1,waveform b,1,waveform b exist,1,waveform c,1,waveform c exist,1,waveform max,200,waveform min,1,voltage ac all,0.000,voltage ac all max,300.000,voltage ac all min,0.000,voltage ac all max reason,2,voltage ac all min reason,0,voltage ac a,0.000,voltage ac a max,300.000,voltage ac a

min,0.000,voltage ac a max reason,2,voltage ac a min reason,0,voltage ac b,0.000,voltage ac b max,300.000,voltage ac b min,0.000,voltage ac b max reason,2,voltage ac b min reason,0,voltage ac c,0.000,voltage ac c max,300.000,voltage ac c min,0.000,voltage ac c max reason,2,voltage ac c min reason,0,voltage dc all,0.000,voltage dc all max,425.000,voltage dc all min,-425.000,voltage dc all max reason,0,voltage dc all min reason,0,voltage dc a,0.000,voltage dc a max,425.000,voltage dc a min,-425.000,voltage dc a max reason,0,voltage dc a min reason,0,voltage dc b,0.000,voltage dc b max,425.000,voltage dc b min,-425.000,voltage dc b max reason,0,voltage dc b min reason,0,voltage dc c,0.000,voltage dc c max,425.000,voltage dc c min,-425.000,voltage dc c max reason,0,voltage dc c min reason,0,phase b,120.000,phase c,240.000,phase max,360.000,phase min,0.000

8.7.14 IEC413 Option Interharmonics Commands

The following SCPI commands apply only to AFX models with the -413 Option installed. The presence of this option can be checked using the *IDN? Query to check for the letter “C” in the AXF Model number. Examples: 3150AFX-4AGC”. See section 4.16 on page 49 for more details.

Command Syntax	[SOURCE:]INTHarmonic:FREQuency
Description	Sets the frequency of the interharmonic voltage component for all phases. The query format returns the active setting
Parameters	Frequency
Parameter Format	<nr2>
Example	INTH:FREQ 470
Query Format	[SOURCE:]INTHarmonic:FREQuency?
Description	Query format returns the interharmonic frequency setting.
Returned Data Format	<nr2>
Query Example	INTH:FREQ? 470.0000
Command Syntax	[SOURCE:]INTHarmonic:FREQuency:DEFault
Description	Sets the default frequency of the inter harmonic voltage component for all phases. The factory default setting is 1800 Hz.
Parameters	Frequency
Parameter Format	<nr2>
Example	INTH:FREQ:DEF 90
Query Format	[SOURCE:]INTHarmonic:FREQuency:DEFault?
Description	Query format returns the interharmonic frequency setting.
Returned Data Format	<nr2>
Query Example	INTH:FREQ:DEF? 90.0000
Query Format	[SOURCE:]INTHarmonic:FREQuency:MAXimum?
Description	Returns the maximum value for the interharmonic frequency setting which is 10,000 Hz..
Returned Data Format	<nr2>
Query Example	INTH:FREQ:MAX? 10000.0000
Query Format	[SOURCE:]INTHarmonic:FREQuency:MINimum?
Description	Returns the minimum value for the interharmonic frequency setting which is 15 Hz..
Returned Data Format	<nr2>
Query Example	INTH:FREQ:MIN? 15.0000

Command Syntax	[SOURCE:]INTHarmonic:VOLTage[:AC#]
Description	Sets the inter harmonic voltage amplitude for the selected phase (1 = A, 2 = B, 3 = C) or for all three phases if the phase selection is omitted in Vac RMS
Parameters	Voltage
Parameter Format	<nr2>
Example	INTH:VOLT:AC1 12.00
Query Format	[SOURCE:]INTHarmonic:VOLTage[:AC#]?
Description	Query format returns the interharmonic amplitude setting.
Returned Data Format	<nr2>
Query Example	INTH:VOLT? 12.0000, 0.0000, 0.0000
Command Syntax	[SOURCE:]INTHarmonic:VOLTage:AC#:DEFault
Description	Sets the default amplitude of the interharmonic voltage component for all phases. The factory default setting is 0.000 Vrms.
Parameters	Frequency
Parameter Format	<nr2>
Example	INTH:VOLT:AC:DEF 5
Query Format	[SOURCE:]INTHarmonic:VOLTage:AC#:DEFault?
Description	Query format returns the interharmonic default amplitude setting.
Returned Data Format	<nr2>
Query Example	INTH:VOLT:AC:DEF? 5.0000, 5.0000, 5.0000
Query Format	[SOURCE:]INTHarmonic:VOLTage:AC#:MAXimum?
Description	Returns the maximum value for the interharmonic amplitude setting which is 300.0000 Vac RMS.
Returned Data Format	<nr2>
Query Example	INTH:VOLT:AC:MAX? 300.0000
Query Format	[SOURCE:]INTHarmonic:VOLTage:AC#:MINimum?
Description	Returns the minimum value for the interharmonic amplitude setting which is 0.0000 Vac RMS.
Returned Data Format	<nr2>
Query Example	INTH:VOLT:AC:MIN? 0.0000

Command Syntax	[SOURCE:]INTHarmonic:PHASe#
Description	This command sets the interharmonic voltage phase angle with respect to the phase A interharmonic fundamental for the selected phase (2 = B, 3 = C) or for both phases if the phase selection is omitted in degrees.
Parameters	Phase
Parameter Format	<nr2>
Example	INTH:PHAS2 45.00
Query Format	[SOURCE:]INTHarmonic:PHASe?
Description	Query format returns the interharmonic voltage phase angle with respect to the phase A setting.
Returned Data Format	<nr2>
Query Example	INTH:PHAS2? 45.0000
Command Syntax	[SOURCE:]INTHarmonic:PHASe#:DEFault
Description	The default interharmonic voltage phase angle for each phase or all phases can be selected using the following command: Factory default is 0.000° for phase A, 120.000° for phase B and 240.000° for phase C.
Parameters	Frequency
Parameter Format	<nr2>
Example	INTH:PHAS2:DEF 90
Query Format	[SOURCE:]INTHarmonic:PHASe#:DEFault?
Description	Query format returns the interharmonic default voltage phase angle setting.
Returned Data Format	<nr2>
Query Example	INTH:PHAS:DEF? 0.0000, 120.0000, 240.0000
Query Format	[SOURCE:]INTHarmonic:PHASe#:MAXimum?
Description	Returns the upper interharmonic voltage phase angle setting range for each phase or all phases. The Maximum set values in 360.000°.
Returned Data Format	<nr2>
Query Example	INTH:PHAS:MAX? 360.0000
Query Format	[SOURCE:]INTHarmonic:PHASe#:MINimum?
Description	Returns the lower interharmonic voltage phase angle setting range for each phase or all phases. Minimum set value is 0.000°.
Returned Data Format	<nr2>
Query Example	INTH:PHAS:MIN? 0.0000

Command Syntax	[SOURCE:]INTHarmonic:STATe
Description	This command enables (1) or disables Inter Harmonics mode. When off, no interharmonics are generated. This command can only be sent while the OUTPUT is OFF. If the OUTPUT is ON, an error is generated and no change of state occurs. (“Unable to execute this action with output enabled”).
Parameters	< 0 OFF 1 ON >
Parameter Format	
Example	INTH:STAT ON
Query Format	[SOURCE:]INTHarmonic:STATe?
Description	Query format returns the interharmonic state setting.
Returned Data Format	
Query Example	INTH:STAT? 1

8.8 Status Commands

Status commands control status and event registers. These commands are aliases for some of the IEEE488.2 common commands and may be used interchangeably. Refer to section 8.14, “Status and Events Registers” for details on status and event register configurations.

The following status commands are supported.

Command	Description
STATus:OPERation[:EVENT]?	Queries the Operation Status Event Register
STATus:OPERation:CONDition?	Queries the Operation Status Condition Register
STATus:OPERation:ENABle <nr1>	Sets the Operation Status Enable Register
STATus:OPERation:ENABle?	Queries the Operation Status Enable Register
STATus:QUESTionable[:EVENT]?	Queries the Questionable Status Event Register
STATus:QUESTionable:CONDition?	Queries the Questionable Status Condition Register
STATus:QUESTionable:ENABle <nr1>	Sets the Questionable Status Enable Register
STATus:QUESTionable:ENABle?	Queries the Questionable Status Enable Register
STATus:PRESet	Presets the Status Registers

Query Format	STATus:OPERation[:EVENT]?
Description	Queries the Operation Status Event Register.
Returned Data Format	<nr1>
Query Example	STAT:OPER? 0
Query Format	STATus:OPERation:CONDition?
Description	Queries the Operation Status Condition Register.
Returned Data Format	<nr1>
Query Example	STAT:OPER:COND? 0
Command Syntax	STATus:OPERation:ENABle <nr1>
Description	Sets the content Operation Status Enable Register.
Parameters	0-32767
Parameter Format	<nr1>
Example	STAT:OPER:ENAB 255
Query Format	STATus:OPERation:ENABle?
Returned Data Format	<nr1>
Query Example	STAT:OPER:ENAB? 6144

Query Format	STATus:QUEStionable[:EVENT]?
Description	Queries the Questionable Status Event Register.
Returned Data Format	<nr1>
Query Example	STAT:QUES? 0
Query Format	STATus:QUEStionable:CONDition?
Description	Queries the Questionable Status Condition Register.
Returned Data Format	<nr1>
Query Example	STAT:QUES:COND? 0
Command Syntax	STATus:QUEStionable:ENABle
Description	Sets the content of the Questionable Status Enable Register.
Parameters	0-32767
Parameter Format	<nr1>
Example	STAT:QUES:ENAB 255
Query Format	STATus:QUEStionable:ENABle?
Returned Data Format	<nr1>
Query Example	STAT:QUES:ENAB? 255
Command Syntax	STATus:PRESet
Description	The Status Preset command presets the Status Registers. The Operational Status. Enable Register is set to 0 and the Questionable Status Enable Register is set to 0.
Parameters	None
Parameter Format	n/a
Example	STAT:PRES

8.9 System Commands

Systems commands control system level functions or return model and revision information on the connected unit. The following system commands are supported.

8.9.1 System Error Commands

Query Format **SYSTem:ERRor[:NEXT]?**
Description This command returns next available error message from the error queue. If no more error messages are available, returns 0, "NO ERROR" result. Available error messages are:

Returned Data Format	ERROR	Description
	-0, "No error"	No error detected
	-100, "Command error"	indicates invalid command or query received
	-102, "Command error: Syntax error."	Incorrect command syntax
	-200, "Execution error"	indicates can't execute command with parameters received
	-222, "Command error: Data out of range."	Data exceeds available parameter range
	-300, "Device-specific error"	indicates UPC not properly configured
	-400, "Query error"	indicates query aborted

Query Example SYST:ERR?
-102, "Command error: Syntax error."

Query Format **SYSTem:ERRor:ALL?**
Description Returns all available error messages as a of error numbers and clears the error message queue.

Returned Data Format TOTAL_ERRORS ,ERRORS,CODE(INDEX),DESCRIPTION(INDEX),
CODE(INDEX+1), DESCRIPTION(INDEX+1),..., CODE(INDEX+N),
DESCRIPTION(INDEX+N),...

Query Example SYST:ERR:ALL?
0,0
SYST:ERR:ALL?
2,2,-102, "Command error: Syntax error. Webpage
interface.;2022/10/12 18:23:37",-102, "Command error: Syntax error.
Webpage interface.+2022/10/12 18:23:50"

Command Syntax **SYSTem:ERRor:ALL:CLEAR**
Description This command clears the error message queue.
Parameters None
Parameter Format n/a
Example SYST:ERR:ALL:CLEAR

Command Syntax	SYSTem:ERRor:ALL:NOCLEAR? < Optional: Index>
Description	Returns all available error messages as a single unterminated string but does not clear the error message queue .
Returned Data Format	<p><nr1>,<nr1>,...<nr1></p> <p>Format of response: YYYY/MM/DD,HH:MM::SS,S.NS,TOTAL_ERRORS,INDEX,ERRORS,CODE (INDEX),DESCRIPTION(INDEX),CODE(INDEX+1),DESCRIPTION(INDEX+1),...,CODE(INDEX+N),DESCRIPTION(INDEX+N),...</p> <p>Response Legend: YYYY/MM/DD,HH:MM::SS,S.NS is the timestamp of the latest error pushed to the queue. S is absolute seconds and NS absolute nanoseconds. TOTAL_ERRORS are the total errors in the queue. INDEX is 1 by default if not passed as optional argument. ERRORS is the total errors returned in the response. As there may be too many errors the response may return a few of them starting from the INDEX. The INDEX is useful to navigate the queue. CODE is the error code and DESCRIPTION the description.</p>
Query Example	<p>SYST:ERR:ALL:NOCLEAR? 2018/05/29,14:29:53,1207438.903668873,0,1,0</p> <p><u>For no errors:</u> <i>>SYSTem:ERRor:ALL:NOCLEAR? 2022/10/12,18:17:01,122450.794695832,0,1,0</i></p> <p><u>Two errors in the queue:</u> <i>>SYSTem:ERRor:ALL:NOCLEAR? 2022/10/12,18:17:19,122467.903705666,2,1,2,-102,"Command error: Syntax error. Webpage interface.;"2022/10/12 18:17:18",-102,"Command error: Syntax error. Webpage interface.;"2022/10/12 18:17:19" >SYSTem:ERRor:ALL:NOCLEAR? 2 2022/10/12,18:17:19,122467.903705666,2,2,1,-102,"Command error: Syntax error. Webpage interface.;"2022/10/12 18:17:19"</i></p>

Command Syntax	SYSTem:ERRor:POE
Description	This command sets the Power on Error reporting mode. Returns status of Power on Error setting as 1 (enabled) or 0 (disabled).
Parameters	< 0 OFF 1 ON >
Parameter Format	
Example	SYST:ERR:POE ON
Query Format	SYSTem:ERRor:POE?
Returned Data Format	
Query Example	SYST:ERR:POE? 1

8.9.2 System Information Commands

Command Syntax	SYSTem:BEEP
Description	This command generates an audible beep at the front panel of the power source.
Parameters	None
Parameter Format	n/a
Example	SYST:BEEP

Query Format	SYSTem:FW:FRONTPANEL:VERsion?
Description	Returns the firmware revision for the front panel processor.
Returned Data Format	<cr>
Query Example	SYST:FW:FRONTPANEL:VER? 2.0.0

Query Format	SYSTem:FW:FRONTPANEL:APPS:VERsion?
Description	Returns the firmware revision for the front panel application program.
Returned Data Format	<cr>
Query Example	SYST:FW:FRONTPANEL:APPS:VER? 2.0.0

Query Format	SYSTem:FW:IO:VERsion?
Description	Returns the firmware revision for the Auxiliary I/O board processor on AFX-xA version power sources.
Returned Data Format	<cr>
Query Example	SYST:FW:IO? 1.0.4

Query Format	SYSTem:FW:POWER:VERsion?
Description	Returns the revision number of the power source's power stages.
Returned Data Format	<nr2>-<nr2>
Query Example	SYST:FW:POWER:VER? 81.0.0-77.1.0

Query Format	SYSTem:LANGuage:CATalog?
Description	Returns list of available languages that can be selected for front panel operation.
Returned Data Format	<cr>
Query Example	SYST:LANG? english, chinese
Query Format	SYSTem:LXI:FEATures?
Description	R eturns string listing supported LXI features.
Returned Data Format	<cr>
Query Example	SYST:LXI:FEAT? None
Query Format	SYSTem:LXI:VERSion?
Description	Returns LXI revision compliance version number.
Returned Data Format	<cr>
Query Example	SYST:LXI:VERSION? LXI Core 2011
Query Format	SYSTem:MODE?
Description	Returns LOCAL (0) or REMOTE (1) front panel status. Use IEEE 488.2 command commands *LLO to lock front panel and *GTL to release front panel operation.
Returned Data Format	
Query Example	SYST:MODE? 1
Query Format	SYSTem:SERIALNUM?
Description	Returns the serial number of the power source. Same information can be queried with the *IDN? command
Returned Data Format	<nr1>
Query Example	SYST:HWREV? 0
Query Format	SYSTem:TIME?
Description	Returns real time clock date and time. Note: Since both date and time are returned, there is no
Returned Data Format	SYSTem:DATE?
Query Example	<mm/dd/yy hh:mm:ss:mm SYSTem:TIME? 29/05/2018 14:40:57

Query Format Description Returned Data Format Query Example	SYSTem:TIME:SOURce? Queries source of date and time information. <cr> SYST:TIME:SOUR? NTP Note: NTP stands for “Network Time Protocol”. A protocol built on top of TCP/IP that assures accurate local timekeeping with reference to radio, atomic or other clocks located on the Internet. This protocol is capable of synchronizing distributed clocks within milliseconds over long time periods. It is defined in STD 12, RFC 1119 (RFC = Request for comment. RFCs are used by the Internet Engineering Task Force (IETF) and other standards bodies.
Query Format Description Returned Data Format Query Example	SYSTem:TIME:UTC? Returns the UTC time, independent of the zone. DD/MM/YYYY HH:MM:SS SYST:TIME:UTC? 29/05/2019 14:40:57
Command Syntax Description Example Query Format Description Returned Data Format Query Example	SYSTem:TIME:ZONE <ZONE> Set the zone, allowed values are GMT+/-X. SYST:TIME:ZONE GMT-7 SYSTem:TIME:ZONE? Returns the current time zone setting, normally GMT+/-X <cr> SYST:TIME:ZONE? GMT-7
Query Format Description Returned Data	SYSTem:TIME:ZONE:CATalog? Returns the available zones. GMT-12,GMT-11,GMT-10,GMT-9,GMT-8,GMT-7,GMT-6,GMT-5,GMT-4, GMT-3, GMT-2,GMT-1,GMT+0,GMT+1,GMT+2,GMT+3,GMT+4,GMT+5, GMT+6,GMT+7,GMT+8,GMT+9,GMT+10,GMT+11,GMT+12,GMT+13, GMT+14
Command Syntax Description Parameters Example Query Format Description Returned Data	SYSTem:TIME:ZONE:LEAP <0 OFF 1 ON> Enables or Disables Leap Second mode. 1 or ON to consider leap seconds, otherwise 0 or OFF SYST:TIME:LEAP ON SYSTem:TIME:ZONE:LEAP? Returns 1 if it considers leap seconds, otherwise 0. 1 = Leap seconds considered, 0 = Leap seconds ignored

<p>Command Syntax Description</p>	<p>SYSTem:TIME:SOURce < RTC NTP > Set the time source, RTC is the local real time clock of the front panel. NTP is internet time protocol. NTP requires internet connection. If NTP is used with internet connection then the RTC is updated every time the NTP synchronizes.</p>
<p>Parameters Example</p>	<p>< RTC NTP > SYST:TIME:SOUR NTP</p>
<p>Query Format Description Returned Data</p>	<p>SYSTem:TIME:SOURce:CATalog? Returns the available time source options, NTP or RTC. NTP, RTC</p>
<p>Query Format Description Returned Data</p>	<p>SYSTem:TIME:SOURce:NTP:SERVer? Returns “pool.ntp.org” This is the server that uses the unit NTP service. pool.ntp.org</p>
<p>Command Syntax Description Parameters Example</p>	<p>SYSTem:TIME:SOURce:NTP:SYNC <OPTIONAL: SERVER> Forces an NTP sync. If the argument is not passed then it uses “pool.ntp.org”. Any IP/domain that runs a NTP server can be used. Alternative commons servers are “time.windows.com” or “time.nist.gov”. < time server domain > SYST:TIME:SOUR:NTP:SYNC</p>
<p>Command Syntax Description Parameters Example</p>	<p>SYSTem:TIME:SOURce:NTP:REStart Restarts the NTP service none SYST:TIME:SOUR:NTP:REST</p>
<p>Query Format Description Returned Data Format Query Example</p>	<p>SYSTem:VERSion? Returns SCPI standard revision version. <nr2> SYST:VERS? 1992.0</p>
<p>Query Format Description Returned Data Format Query Example</p>	<p>SYSTem:XFMRRATIO? Returns the transformer option (T Option) voltage ratio. If no transformer option is installed and configured, this query will return a value of 0.000. See also the [SOURce:]COUPLing command. <nr2> SYSTem:XFMRRATIO? 1.3333</p>

8.9.3 System Interface Commands

These commands allow programming front panel user interface controls and functions of the power source, including the output programming preset soft key values. The same can be accomplished by the user from the front panel. Using a program to set these value can ensure they are always set to a known value if this is important for operator use of the power source in a specific test situation.

8.9.3.1 Preset Syntax

The syntax for all these commands is very similar. Prefix is always “SYSTem:INTERFace:PRESET:” followed by the parameter. Available soft key preset parameters are:

- VOLTage[:AC]
- VOLTage:DC
- FREQuency
- PHASe
- CURRent:LIMit
- POWer:LIMit
- KVA:LIMit

To program or query a specific soft key number (1 ~ 5), append “SK#” to the command where # is a value from 1 through 5 for soft key 1 through 5. (Top soft key =1, bottom soft key = 5).

8.9.3.2 Command parameters

Available softkey parameters are:

- MIN MIN is the preset value for the min allowable setting based on the power source model
- MAX MAX is the the preset value for the max allowable setting based on the power source model
- DEF DEF sets the preset value to factory default
- Value A <nr1> value between MIN and MAX may be specified instead.

Up to five sets of parameters can be appended to these commands to program more than one soft key for the same parameter setting with a single command string.

Example:

```
SYST:INTERF:PRESET:VOLT MAX, MIN, 108, 140
```

Programs the voltage AC soft keys as follows:

```
SK1 = MAX or 300, SK2 = MIN or 0, SK3 = 108, SK4 = 140.
```

8.9.3.3 Preset Commands Listing

The following lists shows all available soft key preset programming commands.

Voltage AC

SYSTem:INTERFace:PRESET:VOLTage[:AC] <REQ: MIN|MAX|DEF|Value, OPT: MIN|MAX|DEF|Value, OPT: MIN|MAX|DEF|Value, OPT: MIN|MAX|DEF|Value, OPT: MIN|MAX|DEF|Value>

SYSTem:INTERFace:PRESET:VOLTage[:AC]? <OPT: ALL|DEF> <OPT: ALL|DEF>

SYSTem:INTERFace:PRESET:VOLTage[:AC]:SK# <REQ: MIN|MAX|DEF|Value>

SYSTem:INTERFace:PRESET:VOLTage[:AC]:SK#?

Voltage DC

SYSTem:INTERFace:PRESET:VOLTage:DC <REQ: MIN|MAX|DEF|Value, OPT: MIN|MAX|DEF|Value, OPT: MIN|MAX|DEF|Value, OPT: MIN|MAX|DEF|Value, OPT: MIN|MAX|DEF|Value>

SYSTem:INTERFace:PRESET:VOLTage:DC? <OPT: ALL|DEF> <OPT: ALL|DEF>

SYSTem:INTERFace:PRESET:VOLTage:DC:SK# <REQ: MIN|MAX|DEF|Value>

SYSTem:INTERFace:PRESET:VOLTage:DC:SK#?

Frequency

SYSTem:INTERFace:PRESET:FREQuency <REQ: MIN|MAX|DEF|Value, OPT: MIN|MAX|DEF|Value, OPT: MIN|MAX|DEF|Value, OPT: MIN|MAX|DEF|Value>

SYSTem:INTERFace:PRESET:FREQuency? <OPT: ALL|DEF> <OPT: ALL|DEF>

SYSTem:INTERFace:PRESET:FREQuency:SK# <REQ: MIN|MAX|DEF|Value>

SYSTem:INTERFace:PRESET:FREQuency:SK#?

Phase Angle

SYSTem:INTERFace:PRESET:PHASe <REQ: MIN|MAX|DEF|Value, OPT: MIN|MAX|DEF|Value, OPT: MIN|MAX|DEF|Value, OPT: MIN|MAX|DEF|Value>

SYSTem:INTERFace:PRESET:PHASe? <OPT: ALL|DEF> <OPT: ALL|DEF>

SYSTem:INTERFace:PRESET:PHASe:SK# <REQ: MIN|MAX|DEF|Value>

SYSTem:INTERFace:PRESET:PHASe:SK#?

Current Limit

SYSTem:INTERFace:PRESET:CURRent:LIMit <REQ: MIN|MAX|DEF|Value, OPT: MIN|MAX|DEF|Value, OPT: MIN|MAX|DEF|Value, OPT: MIN|MAX|DEF|Value>

SYSTem:INTERFace:PRESET:CURRent:LIMit? <OPT: ALL|DEF> <OPT: ALL|DEF>

SYSTem:INTERFace:PRESET:CURRent:LIMit:SK# <REQ: MIN|MAX|DEF|Value>

SYSTem:INTERFace:PRESET:CURRent:LIMit:SK#?

Power Limit

SYSTem:INTERFace:PRESET:POWer:LIMit <REQ: MIN|MAX|DEF|Value, OPT: MIN|MAX|DEF|Value, OPT: MIN|MAX|DEF|Value, OPT: MIN|MAX|DEF|Value>

SYSTem:INTERFace:PRESET:POWer:LIMit? <OPT: ALL|DEF> <OPT: ALL|DEF>

SYSTem:INTERFace:PRESET:POWer:LIMit:SK# <REQ: MIN|MAX|DEF|Value>

SYSTem:INTERFace:PRESET:POWER:LIMit:SK#?

Apparent Power Limit

SYSTem:INTERFace:PRESET:KVA:LIMit <REQ: MIN|MAX|DEF|Value, OPT: MIN|MAX|DEF|Value, OPT: MIN|MAX|DEF|Value, OPT: MIN|MAX|DEF|Value, OPT: MIN|MAX|DEF|Value>

SYSTem:INTERFace:PRESET:KVA:LIMit? <OPT: ALL|DEF> <OPT: ALL|DEF>

SYSTem:INTERFace:PRESET:KVA:LIMit:SK# <REQ: MIN|MAX|DEF|Value>

SYSTem:INTERFace:PRESET:KVA:LIMit:SK#?

Examples of programming User Preset Soft keys:

SYST:INTERF:PRESET:VOLT:AC 115.000,230.000,300.000,MAX

SYST:INTERF:PRESET:VOLT:DC MAX,200.000,0.000,-200.000,MIN

SYST:INTERF:PRESET:FREQ 50.000,60.000,400.000,800.000,1200.000

SYST:INTERF:PRESET:PHAS 0.000,90.000,120.000,180.000,240.000

SYST:INTERF:PRESET:CURR:LIM MAX,15.000,5.000

SYST:INTERF:PRESET:POW:LIM MAX,4.000,2.000,1.000

SYST:INTERF:PRESET:KVA:LIM MAX,4.000,2.000,1.000

Examples of programming a specific User Preset Soft key:

SYST:INTERF:PRESET:VOLT:AC:SK1 115

Examples of querying programming User Preset Soft key settings:

SYSTem:INTERF:PRESET:VOLT:AC? -> 115.000,230.000,300.000,MAX

SYSTem:INTERF:PRESET:VOLT:DC? -> MAX,200.000,0.000,-200.000,MIN

SYSTem:INTERF:PRESET:FREQ? -> 50.000,60.000,400.000,800.000,1200.000

SYSTem:INTERF:PRESET:PHAS? -> 0.000,90.000,120.000,180.000,240.000

SYSTem:INTERF:PRESET:CURR:LIM? -> MAX,15.000,5.000

SYSTem:INTERF:PRESET:POW:LIM? -> MAX,4.000,2.000,1.000

SYSTem:INTERF:PRESET:KVA:LIM? -> MAX,4.000,2.000,1.000

Example of querying programming User Preset for a specific soft key number:

SYST:INTERF:PRESET:VOLT:AC:SK1? -> 115.000

8.9.3.4 Other Front Panel Function Commands

These commands are equivalent to some of the functions available in the LOCAL INTERFACE settings.

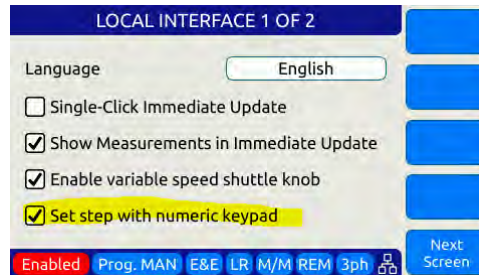

Beeper Volume - Range is 0 through 10:

SYSTem:INTERFace:VOLUme <VOLUME>

SYSTem:INTERFace:VOLUme?

LCD Brightness - Range is 0 through 10:

SYSTem:INTERFace:LCD[:BRIGHTness] <BRIGHTNESS>

SYSTem:INTERFace:LCD[:BRIGHTness]?

Keypad Backlit Brightness - Range is 0 through 10:

SYSTem:INTERFace:KEYS:BRIGHTness <BRIGHTNESS>

SYSTem:INTERFace:KEYS:BRIGHTness?

Key Press Sounds:

SYSTem:INTERFace:KEYS:SOUNDS <ON|OFF>

SYSTem:INTERFace:KEYS:SOUNDS?

Set Resolution Step Size with the numeric keypad

SYSTem:INTERFace:KEYS:STEPset <ON|OFF>

SYSTem:INTERFace:KEYS:STEPset?

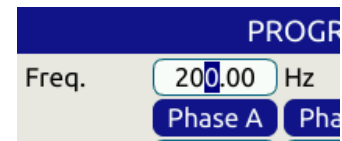

Single Click Update Mode:

SYSTem:INTERFace:IMMEDIATEupdate:SINGLEclick <ON|OFF>

SYSTem:INTERFace:IMMEDIATEupdate:SINGLEclick?

Show Measurements in Immediate Update:

SYSTem:INTERFace:IMMEDIATEupdate:SHOWMEASurements <ON|OFF>

SYSTem:INTERFace:IMMEDIATEupdate:SHOWMEASurements?

Variable Shuttle Knob Speed - Range is 0 through 10:

SYSTem:INTERFace:KNOB:SPEED <SPEED>

SYSTem:INTERFace:KNOB:SPEED?

8.9.4 System Configuration Commands

Query Format	SYSTem:MAXKVA?
Description	Returns maximum available kVA output capability of the power source. Example for 3150AFX model = 15.0000
Returned Data Format	<nr2>
Query Example	SYST:MAXKVA? 15.000
Query Format	SYSTem:MAXCURRent?
Description	Returns maximum available RMS or DC output current capability of the power source. Example for 3150AFX model = 41.6667.
Returned Data Format	<nr2>
Query Example	SYST:MAXCURR? 41.6667
Query Format	SYSTem:MAXVOLTage?
Description	Returns maximum available RMS or DC voltage output capability of the power source. Example for 3150AFX model = 300.
Returned Data Format	<nr1>
Query Example	SYST:MAXVOLT? 300
Command Syntax	SYSTem:COMPAtible
Description	Sets Pacific Power Source UPC controller compatibility mode. This mode allows use of the power source with legacy software.
Parameters	< 0 DISABLE 1 UPC >
Parameter Format	
Example	SYST:COMP UPC
Query Format	SYSTem:COMPAtible?
Returned Data Format	
Query Example	SYST:COMP? 1
Query Format	SYSTem:HWREVision?
Description	Returns the hardware revision letter of the power source
Returned Data Format	<cr>
Query Example	SYST:HWREV? A

Command Syntax	SYSTem:LANGuage
Description	Sets Pacific Power Source UPC controller compatibility mode. This mode allows use of the power source with legacy software.
Parameters	< english Chinese > Note: Refer to SYSTem:LANGuage:CATalog? query command for list of supported languages.
Parameter Format	<cr>
Example	SYST:LANG chinese
Query Format	SYSTem:LANGuage?
Returned Data Format	
Query Example	SYST:LANG? chinese

These commands allow complete system configurations to be exported or imported.

Command Syntax	SYSTem:EXPort <OPT: CONFIGURATION, OPT: WAVEFORMS, OPT: PROGRAMS, OPT: SETPOINTS, OPT: [NAME, NAMEFILE]>
Description	Exports complete record of system configuration of the power source to a compressed file. If argument name is omitted it is stored in temporal/DATE—TIME.7z otherwise in temporal/NAMEFILE.7z. The others arguments indicate what is going to be exported, if none of them are passed all is going to be exported.
Parameters	<OPT: CONFIGURATION, OPT: WAVEFORMS, OPT: PROGRAMS, OPT: SETPOINTS, OPT: [NAME, NAMEFILE]>
Parameter Format	<cr>
Example	SYST:EXPORT SYST:EXPORT NAME,TEST SYST:EXPORT SETPOINTS,NAME,TEST2 SYST:EXPORT SETPOINTS, WAVEFORMS,NAME,TEST3

Command Syntax	SYSTem:IMPOrt <OPT: CONFIGURATION, OPT: WAVEFORMS, OPT: PROGRAMS, OPT: SETPOINTS, [NAME, NAMEFILE]>
Description	Imports complete system configuration records of the power source. The compressed file has to be in /temporal/NAMEFILE.7z. The other others arguments indicate what will be imported, if none of them are passed all is going to be imported.
Parameters	<OPT: CONFIGURATION, OPT: WAVEFORMS, OPT: PROGRAMS, OPT: SETPOINTS, [NAME, NAMEFILE]>
Parameter Format	<cr>
Example	SYST:IMPORT NAME,TEST

8.9.5 Parallel System Commands

Command Syntax	SYSTem:DISCOVERY
Description	Initiates discovery of the number of paralleled power sources
Parameters	None
Parameter Format	n/a
Example	SYST:DISCOVERY
Query Format	SYSTem:PARALLELUNITS?
Description	Returns the number of power sources found. The response will be different for a Parallel AFX system vs a Series/Parallel AFXS system. For a parallel AFX system, this command returns the total number of units, 2 or higher. For a Series or Series/Parallel system, if SOURCE:SERIES is 0/OFF, it returns the total units, same as a parallel only system. If SOURCE:SERIES is 1, it returns the total number units divided by two. SYSTem:CONNECTEDUNITS? returns the total units no matter the value of SOURCE:SERIES. This is equal to SYSTem:SERIESUNITS? * SYSTem:PARALLELUNITS?
Returned Data Format	<nr1>
Query Example	SYST:PARALLELUNITS? 1
Command Syntax	SYSTem:PARALLELUNITS:EXPEcted
Description	Sets the number of power sources that should be connected to the system interface bus.
Parameters	1 – 200
Parameter Format	<nr1>
Example	SYST:PARALLELUNITS:EXPE 4
Query Format	SYSTem:PARALLELUNITS:EXPEcted?
Returned Data Format	<nr1>
Query Example	SYST:PARALLELUNITS:EXPE? 4

Multi-Unit System Configuration Command Examples:

30kVA Parallel Only AFX System	30kVA Series/Parallel AFSX System
SOURCE:SERIES 0	SOURCE:SERIES 1
SYSTem:SERIESUNITS? = 1	SYSTem:SERIESUNITS? = 2
SYSTem:PARALLELUNITS? = 2	SYSTem:PARALLELUNITS? = 1
SYSTem:CONNECTEDUNITS? = 2	SYSTem:CONNECTEDUNITS? = 2
60kVA Parallel Only AFX System	60kVA Series/Parallel AFSX System
SOURCE:SERIES 0	SOURCE:SERIES 1
SYSTem:SERIESUNITS? = 1	SYSTem:SERIESUNITS? = 2
SYSTem:PARALLELUNITS? = 4	SYSTem:PARALLELUNITS? = 2
SYSTem:CONNECTEDUNITS? = 4	SYSTem:CONNECTEDUNITS? = 4

8.9.6 System Sanitization Commands

Query Format	SYSTem:SANITIZE:CODE?
Description	Returns sanitization password string.
Returned Data Format	<nr1>
Query Example	SYSTem:SANITIZE:CODE? 0659
Command Syntax	SYSTem:SANITIZE <code>
Description	Erases all user data stored in non-volatile memory settings including settings and custom waveforms if required. The code is obtained by the query command above.
Parameters	None
Parameter Format	n/a
Example	SYST:SANITIZE 0659

8.9.7 Communication LAN Commands

Command Syntax	SYSTem:COMMunicate:LAN[:ENABLE]
Description	This command turns remote control via LAN on or off. To control the power source through its LAN interface, this state has to on (1).
Parameters	< 0 OFF 1 ON >
Parameter Format	
Example	SYST:COMM:LAN ON
Query Format	SYSTem:COMMunicate:LAN[:ENABLE]?
Returned Data Format	
Query Example	SYST:COMM:LAN? 1
Command Syntax	SYSTem:COMMunicate:LAN:RESPonse
Description	This command allows the termination character for LAN communication to be defined by the user.
Parameters	0 (AUTO) 1 (\r\n) 2 (\n) 3 (\r)
Parameter Format	<nr1>
Example	SYST:COMM:LAN:REPSONSE 1
Query Format	SYSTem:COMMunicate:LAN:RESPonse?
Returned Data Format	<nr1>
Query Example	SYST:COMM:LAN:RESP? 1

Command Syntax
Description **SYSTem:COMMunicate:LAN:RESPonse:TELNET**
This command allows the termination character for LAN Telnet communication to be defined by the user.

Parameters 0 (AUTO) 1 (\r\n) 2 (\n) 3 (\r)

Parameter Format <nr1>

Example SYST:COMM:LAN:REPSONSE:TELNET 1

Query Format **SYSTem:COMMunicate:LAN:RESPonse:TELNET?**

Returned Data Format <nr1>

Query Example SYST:COMM:LAN:RESP:TELNET?
1

Command Syntax
Description **SYSTem:COMMunicate:SERial:RESPonse**
This command allows the termination character for RS232 communication to be defined by the user.

Parameters 0 (AUTO) 1 (\r\n) 2 (\n) 3 (\r)

Parameter Format <nr1>

Example SYST:COMM:SERial:RESPonse 1

Query Format **SYSTem:COMMunicate:SERial:RESPonse?**

Returned Data Format <nr1>

Query Example SYST:COMM:SER:RESP?
1

Command Syntax
Description **SYSTem:COMMunicate:USB:VIRTualport:RESPonse**
This command allows the termination character for USB communication to be defined by the user.

Parameters 0 (AUTO) 1 (\r\n) 2 (\n) 3 (\r)

Parameter Format <nr1>

Example SYST:COMM:USB:VIRT:RESPonse 1

Query Format **SYSTem:COMMunicate:USB:VIRTualport:RESPonse?**

Returned Data Format <nr1>

Query Example SYST:COMM:USB:VIRT:RESP?
1

Command Syntax
Description **SYSTem:COMMunicate:LXI:RESPonse**
This command allows the termination character for USB communication to be defined by the user.

Parameters 0 (AUTO) 1 (\r\n) 2 (\n) 3 (\r)

Parameter Format <nr1>

Example SYST:COMM:LXI:RESPonse 1

Query Format **SYSTem:COMMunicate:LXI:RESPonse?**

Returned Data Format <nr1>

Query Example SYST:COMM:LXI:RESP?
1

Query Format	SYSTem:COMMunicate:LAN:STATus?
Description	This command returns all LAN settings in a single comma delimited string of values.
Returned Data Format	<cr>, <cr>,.....,<cr>,<cr>
Query Example	SYSTem:COMMunicate:LAN:STATus? 192.168.14.22,255.255.254.0,192.168.15.254,192.168.15.208,AFX-106378937,AFX-106378889,0,1,0
Command Syntax	SYSTem:COMMunicate:LAN:DHCP[:ENABLE]
Description	This command turns DHCP mode for the LAN interface on or off. DHCP = Dynamic Host Configuration Protocol". This protocol automatically provides an IP address and other related information such as the subnet mask and default gateway. When turned off, a static IP address must be assigned by the user instead.
Parameters	< 0 OFF 1 ON >
Parameter Format	
Example	SYST:COMM:LAN:DHCP ON
Query Format	SYSTem:COMMunicate:LAN:DHCP[:ENABLE]?
Returned Data Format	
Query Example	SYST:COMM:LAN:DHCP? 1
Command Syntax	SYSTem:COMMunicate:LAN:DHCP:RENEW
Description	This command renews the lease of an IP address assigned through the DHCP protocol. This may be necessary if the power source has not been used in a while and its IP address lease has expired. If not renewed, a different IP address may be assigned.
Parameters	None
Parameter Format	n/a
Example	SYST:COMM:LAN:DHCP:RENEW
Command Syntax	SYSTem:COMMunicate:LAN:ADDRESS
Description	This command is used to assign a fixed IP address to the power source for LAN communication.
Parameters	ddd.ddd.ddd.ddd (four octets ranging in value from 0 to 255 representing one 16 bit unsigned integer value each.
Parameter Format	<cr>
Example	SYST:COMM:LAN:ADD 132.18.21.105
Query Format	SYSTem:COMMunicate:LAN:ADDRESS?
Returned Data Format	<cr>
Query Example	SYST:COMM:LAN:ADD? 132.18.21.105

Query Format	SYSTem:COMMunicate:LAN:MACaddress?
Description	This query returns the MAC address of the connected power source. The Media Access Control address or MAC address is also referred to as physical address as it is fix and unique to any device on the network. The MAC address for the power source is also printed on the rear panel near the LAN interface connector. It consists of 8 sets of hexadecimal 16 bit unsigned integer values.
Returned Data Format	<cr>
Query Example	SYST:COMM:LAN:MAC? 3A.3F.00.4C.DE.AA.39.8F
Query Format	SYSTem:COMMunicate:LAN:VISA?
Description	Queries the VISA resource name / address string
Returned Data Format	<cr>
Query Example	TCPIP::AFX-1003::INSTR
Command Syntax	SYSTem:COMMunicate:LAN:APPLY
Description	Applies all changes send using the COMM:LAN commands.
Parameters	None
Parameter Format	n/a
Example	SYST:COMM:LAN:APP
Command Syntax	SYSTem:COMMunicate:LAN:MASK
Description	This command sets the IP mark value for the power source LAN interface. It is normally obtained through DHCP. If a static IP must be used, the mask has to set as well.
Parameters	ddd.ddd.ddd.ddd (four octets ranging in value from 0 to 255 representing one 16 bit unsigned integer value each.
Parameter Format	<cr>
Example	SYST:COMM:LAN:MASK 255.255.254.0
Query Format	SYSTem:COMMunicate:LAN:MASK?
Returned Data Format	<cr>
Query Example	SYST:COMM:LAN:MASK? 255.255.254.0
Command Syntax	SYSTem:COMMunicate:LAN:DNSaddress
Description	Sets the IP address for the DNS server
Parameters	ddd.ddd.ddd.ddd (four octets ranging in value from 0 to 255 representing one 16 bit unsigned integer value each.
Parameter Format	<cr>
Example	SYST:COMM:LAN:DNS 132.18.21.208
Query Format	SYSTem:COMMunicate:LAN:DNSaddress?
Returned Data Format	<cr>
Query Example	SYST:COMM:LAN:DNS? 132.18.21.208

<p>Command Syntax Parameters</p>	<p>SYSTem:COMMunicate:LAN:GWAddress Sets the IP address for the Network Gateway. A default gateway is the node on the computer network that the network software uses when an IP address does not match any other routes in the routing table</p>
<p>Parameter Format Example Query Format Returned Data Format Query Example</p>	<p><cr> SYST:COMM:LAN:GWAD 132.18.21.254 SYSTem:COMMunicate:LAN:GWAddress? <cr> SYST:COMM:LAN:GWAD? 132.18.21.254</p>
<p>Command Syntax Description</p>	<p>SYSTem:COMMunicate:LAN:HOST:CONFigured Sets the network host address. The host address is the portion of the address used to identify hosts (any device requiring a Network Interface Card, such as a PC or networked printer) on the network. The network ID, by contrast, is the portion of the address that refers to the network itself.</p>
<p>Parameters</p>	<p>ddd.ddd.ddd.ddd (four octets ranging in value from 0 to 255 representing one 16 bit unsigned integer value each.</p>
<p>Parameter Format Example Query Format Returned Data Format Query Example</p>	<p><cr> SYST:COMM:LAN:HOST 132.18.21.0 SYSTem:COMMunicate:LAN:HOST:CONFigured? <cr> SYST:COMM:LAN:HOST:CONF? 132.18.21.0</p>
<p>Command Syntax Description</p>	<p>SYSTem:COMMunicate:LAN:PASSword Assign a password to enable or disable LAN communications. This feature allows the owner/operator to disable or enable remote LAN access or limit functionality over LAN. Note: There is no query format for this command so the password code cannot be queried back.</p>
<p>Parameters Parameter Format Example</p>	<p>Four digit passcode <nr1? SYST:COMM:LAN:PASS 1234</p>
<p>Command Syntax Description</p>	<p>SYSTem:COMMunicate:LAN:PORT Sets LAN interface port address. For SCPI message communications, the standard port number is 5025.</p>
<p>Parameters Parameter Format Example Query Format Returned Data Format Query Example</p>	<p>1024–49151, default = 5025 <nr1> SYST:COMM:LAN:PORT 5025 SYSTem:COMMunicate:LAN:PORT? <nr1> SYST:COMM:LAN:PORT? 5025</p>

Command Syntax	SYSTem:COMMunicate:LAN:PORT:TELNET
Description	Sets the port address for TELNET protocol
Parameters	1024–49151, default = 5024
Parameter Format	<nr1>
Example	SYST:COMM:LAN:PORT:TELNET 5024
Query Format	SYSTem:COMMunicate:LAN:PORT:TELNET?
Returned Data Format	<nr1>
Query Example	SYST:COMM:LAN:PORT:TELNET? 5024

8.9.8 Communication Serial Port Commands

Command Syntax	SYSTem:COMMunicate:SERial[:ENABLE]
Description	This command is used to turn the RS232 serial interface on or off. To use this interface for remote control of the power source, it must be set to ON.
Parameters	< 0 OFF 1 ON >
Parameter Format	
Example	SYST:COMM:SER ON
Query Format	SYSTem:COMMunicate:SERial[:ENABLE]?
Returned Data Format	
Query Example	SYST:COMM:SER? 1

Query Format	SYSTem:COMMunicate:SERial:STATus?
Description	This command returns all serial port settings
Returned Data Format	Baud rate, status,data bits, stop bits, parity, flow control
Query Example	SYST:COMM:SER:STAT? 921600,0,8,1,0,0

Command Syntax	SYSTem:COMMunicate:SERial:BAUD
Description	This command sets the baud rate for the serial port.
Parameters	< 1200 1800 2400 4800 9600 14400 19200 38400 57600 62500 115200 230400 460800 500000 576000 921600 >
Parameter Format	<nr1>
Example	SYST:COMM:SER:BAUD 115200
Query Format	SYSTem:COMMunicate:SERial:BAUD?
Returned Data Format	<cr1>
Query Example	SYST:COMM:SER:BAUD? 115200

Command Syntax	SYSTem:COMMunicate:SERial:PARity
Description	This command sets the parity for the serial port.
Parameters	< 0 NONE 1 OFF 2 EVEN >
Parameter Format	<nr1>
Example	SYST:COMM:SERial:PAR NONE
Query Format	SYSTem:COMMunicate:SERial:PARity?
Returned Data Format	<nr1>
Query Example	SYST:COMM:SER:PAR? 0
Command Syntax	SYSTem:COMMunicate:SERial:BITS
Description	This command sets the number of data bits used for serial communications. Available settings are 7 or 8
Parameters	< 7 8 >
Parameter Format	<nr1>
Example	SYST:COMM:SER:BITS 8
Query Format	SYSTem:COMMunicate:SERial:BITS?
Returned Data Format	<nr1>
Query Example	SYST:COMM:SER:BITS? 8
Command Syntax	SYSTem:COMMunicate:SERial:SBITs
Description	This command sets the number of stop bits used for serial communications. Available settings are 1 or 2.
Parameters	< 1 2 >
Parameter Format	<nr1>
Example	SYST:COMM:SER:SBIT 2
Query Format	SYSTem:COMMunicate:SERial:SBITs?
Returned Data Format	<nr1>
Query Example	SYST:COMM:SER:SBIT? 2

Command Syntax	SYSTem:COMMunicate:SERial:FLOWcontrol
Description	This command sets the method of handshaking used for serial communications. Available settings are Xon/Xoff or Hardware handshake.
Parameters	< 0 OFF 1 ON >
Parameter Format	
Example	SYST:COMM:SER:FLOW ON
Query Format	SYSTem:COMMunicate:SERial:FLOWcontrol?
Returned Data Format	<nr1>
Query Example	SYST:COMM:SER:FLOW? 1

8.9.9 Communication USB Commands

Command Syntax	SYSTem:COMMunicate:USB:VIRTualport[:ENABLE]
Description	This command enables USB device control using virtual comm driver.
Parameters	< 0 OFF 1 ON >
Parameter Format	
Example	SYST:COMM:USB:VIRT ON
Query Format	SYSTem:COMMunicate:USB:VIRTualport[:ENABLE]?
Returned Data Format	
Query Example	SYST:COMM:USB:VIRT? 1

Command Syntax	SYSTem:COMMunicate:USB:LAN[:ENABLE]
Description	Enables access to embedded webserver using virtual IP Address through USB interface.
Parameters	< 0 OFF 1 ON >
Parameter Format	
Example	SYST:COMM:USB:ETH ON
Query Format	SYSTem:COMMunicate:USB:LAN[:ENABLE]?
Returned Data Format	
Query Example	SYST:COMM:USB:LAN? 1

Command Syntax	SYSTem:COMMunicate:USB:LAN:ADDRESS
Description	Sets the embedded webserver virtual IP Address for USB interface.
Parameters	< 0 OFF 1 ON >
Parameter Format	
Example	SYST:COMM:USB:LAN ON
Query Format	SYSTem:COMMunicate:USB:LAN:ADD?
Returned Data Format	
Query Example	SYST:COMM:USB:LAN:ADD? 192.168.123.1

Command Syntax	SYSTem:COMMunicate:USB:LAN:APPLY
Description	Applies IP settings for Virtual USB Lan interface.
Parameters	None
Parameter Format	N/A
Example	SYST:COMM:USB:LAN:APP
Command Syntax	SYSTem:COMMunicate:USB:LAN:MASK
Description	Sets the embedded webserver virtual IP Mask Address for USB interface.
Parameters	IP Mask
Parameter Format	<cr>
Example	SYST:COMM:USB:LAN ON
Query Format	SYSTem:COMMunicate:USB:LAN:MASK?
Returned Data Format	<cr>
Query Example	SYST:COMM:USB:LAN:MASK? 255.255.255.0

8.9.10 Communication GPIB Commands

Command Syntax	SYSTem:COMMunicate:GPIB:ADDRESS <nr1>
Description	This command sets the GPIB address.
Parameters	< 1..30 >
Parameter Format	<nr1>
Example	SYST:COMM:GPIB:ADD 5
Query Format	SYSTem:COMMunicate:GPIB:ADDRESS?
Returned Data Format	<nr1>
Query Example	SYST:COMM:GPIB:ADD? 5
Command Syntax	SYSTem:COMMunicate:GPIB:ENABLE
Description	Enables access to embedded webserver using virtual IP Address through USB interface.
Parameters	< 0 OFF 1 ON >
Parameter Format	
Example	SYST:COMM:GPIB:ENAB 1
Query Format	SYSTem:COMMunicate:GPIB:ENABLE?
Returned Data Format	
Query Example	SYST:COMM:GPIB:ENAB? 1

Command Syntax	SYSTem:COMMunicate:GPIB:BAUDrate
Description	Sets the internal serial link speed between the GPIB interface and the front panel processor. This setting is set to 921600 bps as a default and should only be changed to a lower setting if there is a problem with the GPIB interface not working reliably.
Parameters	< 1200 1800 2400 4800 9600 14400 19200 38400 57600 62500 115200 230400 460800 500000 576000 921600 >
Parameter Format	<nr1>
Example	SYST:COMM:GPIB:BAUD 921600
Query Format	SYSTem:COMMunicate:GPIB:BAUDrate?
Returned Data Format	<nr1>
Query Example	SYST:COMM:GPIB:BAUD? 921600

8.9.11 System Firmware Commands

Query Format	SYSTem:FW:POWER[:VERsion]?
Description	This command returns the firmware revision of the power converter DSP's. This information is for reference only.
Returned Data Format	<cr>-<cr>
Query Example	SYST:FW:POWER:VER? 81.0.0.RC8-77.1.0
Query Format	SYSTem:FW:FRONTPANEL:VERsion?
Description	This command returns the firmware revision of front panel controller processor. This information is for reference only.
Returned Data Format	<cr>
Query Example	SYST:FW:FRONTPANEL:VER? 2.0.0
Query Format	SYSTem:FW:FRONTPANEL:APPS:VERsion?
Description	This command returns the firmware revision of front panel controller user interface application. This information is for reference only. Note: This revision number is also returned as part of the *IDN? query response.
Returned Data Format	<cr>
Query Example	SYST:FW:FRONTPANEL:APPS:VER? 2.0.0
Query Format	SYSTem:HWREVision?
Description	This command returns the hardware revision (build) of the power source.
Returned Data Format	<nr2>
Query Example	SYST:HWREV? 0

8.9.12 System Remote Access Commands

Command Syntax	SYSTem:REMOte:ACCESS
Description	Sets remote access permission.
Parameters	<0 DISABLED 1 ENABLED>
Parameter Format	
Example	SYST:REM:ACCESS 1
Query Format	SYSTem:REMOte:ACCESS?
Returned Data Format	<cr>
Query Example	SYST:REM:ACCESS? 1
Command Syntax	SYSTem:REMOte:ACCESS:REQuest
Description	This commands results in a pop up dialog on the front panel display requesting the local user to ACCEPT. Confirms presence of a person at the location of the instrument.
Parameters	Alias name. (This argument is optional)
Parameter Format	<cr>
Example	SYSTem:REMOte:ACCESS:REQuest
Query Format	None
Command Syntax	SYSTem:REMOte:ACCESS:LOGIN
Description	This command uses a password as an argument to request access to the instrument. The password can be set on the front panel or using the SYSTem:REMOte:PASSword command
Parameters	Password
Parameter Format	<nr1>
Example	SYSTem:REMOte:ACCESS:LOGIN 1234
Query Format	None
Command Syntax	SYSTem:REMOte:ACCESS:MESSAge <cr>
Description	Allows a user specific message to be displayed at the bottom of the Access Control Browser dialog informing anyone requesting access whom to contact.
Parameters	User Message
Parameter Format	<cr>
Example	SYSTem:REMOte:ACCESS:MESS "Unit is used by John. Please contact 123456789."
Query Format	SYSTem:REMOte:ACCESS:MESSAge?
Returned Data Format	<cr>
Query Example	SYST:REM:ACCESS:MESS? "Unit is used by John. Please contact 123456789."

Command Syntax	SYSTem:REMote:ACCESS:MONItor
Description	Enables or disables remote access monitor mode only. ON by default for backward compatibility.
Parameters	< 0 OFF 1 ON >
Parameter Format	 or <cr>
Example	SYSTem:REMote:ACCESS:MONI ON
Query Format	SYSTem:REMote:ACCESS:MONItor?
Returned Data Format	
Query Example	SYST:REM:ACCESS:MONI? 1
Command Syntax	SYSTem:REMote:FTP:ENAbLe
Description	Enable/disable the FTP service.
Parameters	<0 OFF 1 ON>
Parameter Format	
Example	SYST:REM:FTP:ENA 1
Query Format	SYSTem:REMote:FTP:ENAbLe?
Returned Data Format	
Query Example	SYST:REM:FTP:ENA? 1
Command Syntax	SYSTem:REMote:FTP:PASSword
Description	Sets remote FTP access permission password.
Parameters	password
Parameter Format	<cr>
Example	SYST:REM:FTP:PASS temporal
Query Format	SYSTem:REMote:FTP:PASSword?
Returned Data Format	<cr>
Query Example	SYST:REM:FTP:PASS? temporal
Command Syntax	SYSTem:REMote:SMB:ENAbLe
Description	Enable/disable the samba service.
Parameters	<0 OFF 1 ON>
Parameter Format	
Example	SYST:REM:FTP:ENA 1
Query Format	SYSTem:REMote:SMB:ENAbLe?
Returned Data Format	
Query Example	SYST:REM:SMB:ENA? temporal

Command Syntax	SYSTem:REMOte:SMB:PASSword
Description	Sets remote Samba services access permission password
Parameters	password
Parameter Format	<cr>
Example	SYST:REM:SMB:PASS temporal
Query Format	SYSTem:REMOte:SMB:PASSword?
Returned Data Format	<cr>
Query Example	SYST:REM:SMB:PASS? temporal

8.9.13 System Regional Setting Commands

These commands are used to set regional setting for Dates, Times and Decimal separators. They are relevant when exporting or importing CSV files for use in applications like MS Excel or MS Word.

Command: **SYSTem:REGion:DATEFormat <FORMAT>**

Sets the date display format as either **DD/MM/YYYY** (Asia) EU or **MM/DD/YYYY** (USA)

Example: SYST:REG:DATE DD/MM/YYYY

Query: **SYSTem:REGion:DATEFormat?**

Example: SYST:REG:DATE?
DD/MM/YYYY

Command: **SYSTem:REGion:DATEFormat:CATalog?**

Returns: MM/DD/YYYY,DD/MM/YYYY

Command: **SYSTem:REGion:DECImsymbol <SEPARATOR>**

Sets the decimal separator to either a comma (Asia, EU) or a period (USA). Parameters are "." Or ",".

Example: SYST:REG:DECI ","

Query: **SYSTem:REGion:DECImsymbol?**

Returns decimal separator setting.

Examples SYST:REG:DATE?
,

8.9.14 System Import / Export Commands

These commands allow complete system configurations to be exported or imported.

Command Syntax	SYSTem:EXPort <OPT: CONFIGURATION, OPT: WAVEFORMS, OPT: PROGRAMS, OPT: SETPOINTS, OPT: [NAME, NAMEFILE]>
Description	Exports complete record of system configuration of the power source to a compressed file. If argument name is omitted it is stored in temporal/DATE—TIME.7z otherwise in temporal/NAMEFILE.7z. The others arguments indicate what is going to be exported, if none of them are passed all is going to be exported.
Parameters	<OPT: CONFIGURATION, OPT: WAVEFORMS, OPT: PROGRAMS, OPT: SETPOINTS, OPT: [NAME, NAMEFILE]>
Parameter Format	<cr>
Example	SYST:EXPORT SYST:EXPORT NAME,TEST SYST:EXPORT SETPOINTS,NAME,TEST2 SYST:EXPORT SETPOINTS, WAVEFORMS,NAME,TEST3

Command Syntax	SYSTem:IMPort <OPT: CONFIGURATION, OPT: WAVEFORMS, OPT: PROGRAMS, OPT: SETPOINTS, [NAME, NAMEFILE]>
Description	Imports complete system configuration records of the power source. The compressed file has to be in /temporal/NAMEFILE.7z. The other others arguments indicate what will be imported, if none of them are passed all is going to be imported.
Parameters	<OPT: CONFIGURATION, OPT: WAVEFORMS, OPT: PROGRAMS, OPT: SETPOINTS, [NAME, NAMEFILE]>
Parameter Format	<cr>
Example	SYST:IMPORT NAME,TEST

8.9.15 Miscellaneous System Commands

Command Syntax	SYSTem:BEEP
Description	This command generates a beep from the front panel speaker. May be used in ATE programs to get operator's attention. Make sure the beep volume is not set to 0. See SYSTem:INTERFace:VOLume cmd.
Returned Data Format	<cr>,...,<cr>
Query Format	None
Query Format	SYSTem:MEMory:CATalog?
Description	This command returns the available memory types catalog.
Returned Data Format	<cr>,...,<cr>
Query Example	SYST:MEM:CAT? INTERNAL, RAM
Command Syntax	SYSTem:MEMory:REMove
Description	This command unmounts system memory.
Returned Data Format	<cr>,...,<cr>
Query Format	None

Command Syntax	SYSTem:DELeTe <PATH>
Description	This command deletes a file or folder. The path or filename can be between double quotation marks or not.
Parameters	PATH or FILE
Parameter Format	<cr>
Example	SYST:DEL internal/program/program_1.xml SYST:DEL "internal/program/program_1.xml" SYST:DEL temporal/program/program_1.xml SYST:DEL "temporal/program/program_1.xml"
Query Format	none
Command Syntax	SYSTem:FILE:TYPE? <MEM>
Description	This command returns the file type in numeric available memory types catalog.
Returned Data Format	<nr1>
Query Example	SYST:FILE:TYPE? RAM 0 SYST:FILE:TYPE? INTERNAL 0
Command Syntax	SYSTem:SCREENshot
Description	This command takes a screen shot of the LCD display. The LCD image is saved as a ".png" format image file to folder "internal/screenshots"
Parameters	None
Parameter Format	N/A
Example	SYST:SCREEN
Query Format	none

8.10 Auxiliary I/O System Commands

Commands specific to the auxiliary I/O functions are listed in this section.

8.10.1 System Analog & Digital IO Commands

```

SYSTem:AIO
  :INput[1 | 2 | 3 | .4][?]
    :CATalog?
    :GAIN[?]
      :DEFault?
      :MAXimum?
      :MINimum?
    : OFFSET[?]
      :DEFault?
      :MAXimum?
      :MINimum?
    :RANGe[?]
      :DEFault?
      :MAXimum?
      :MINimum?
    :UNITs?
    :VOLTage?
  :OUTput[1 | 2 | 3 | .4][?]

```

```

:CATalog?
:GAIN[?]
    :DEFault?
    :MAXimum?
    :MINimum?
:OFFSET[?]
    :DEFault?
    :MAXimum?
    :MINimum?
:RANGE[?]
    :DEFault?
    :MAXimum?
    :MINimum?
:UNITS?
:VOLTage?

SYSTem:DIO
    :INput[1 | 2 | 3 | .4][?]
    :FALLing[?]
    :FILtersize[?]
        :DEFault?
        :MAXimum?
        :MINimum?
    :RISing[?]
:OUTput[1 | 2 | 3 | .4][?]
    :CATalog?
    :INVert[?]
    :STATe?
:REMote
    :ENable[?]
    :INHibit[?]
:STROBE
    :OUTPutstate[?]
    :SOURce[?]
    :TRANsient[?]

```

8.10.1.1 SYSTem:AIO:Input

Command Syntax	SYSTem:AIO:INput[n] <cr>
Description	Sets the AFX parameter to be controlled by the analog input.
Parameters	[CURR:LIM CURR:LIM1 CURR:LIM2 CURR:LIM3 FREQ KVA:LIM KVA:LIM1 KVA:LIM2 KVA:LIM3 OFF PHAS2 PHAS3 POW:LIM POW:LIM1 POW:LIM2 POW:LIM3 VOLT:AC VOLT:AC1 VOLT:AC2 VOLT:AC3 VOLT:DC VOLT:DC1 VOLT:DC2 VOLT:DC3] See the “SYSTem:AIO:INput:CATalog?” command response for a list of supported parameters.
Parameter Format	<cr>
Example	SYST:AIO:IN1 VOLTAGE
Query Format	SYSTem:AIO:INput[n]?
Returned Data Format	<cr>
Query Example	SYST:AIO:IN1? VOLTAGE

Query Format	SYSTem:AIO:INput:CATalog?
Description	Returns list of available analog inputs
Returned Data Format	<cr>
Query Example	SYST:AIO:IN:CAT? CURR:LIM,CURR:LIM1,CURR:LIM2,CURR:LIM3,FREQ,KVA:LIM,KVA:LIM1,KVA:LIM2,KVA:LIM3,OFF,PHAS2,PHAS3,POW:LIM,POW:LIM1,POW:LIM2,POW:LIM3,VOLT:AC,VOLT:AC1,VOLT:AC2,VOLT:AC3,VOLT:DC,VOLT:DC1,VOLT:DC2,VOLT:DC3
Command Syntax	SYSTem:AIO:INput[n]:GAIN <nr2>
Description	Sets the full-scale gain of the AFX parameter controlled by the analog input.
Parameters	Full scale value
Parameter Format	<nr2>
Example	SYST:AIO:IN1:GAIN 230.0
Query Format	SYSTem:AIO:INput[n]:GAIN?
Returned Data Format	<nr2>
Query Example	SYST:AIO:IN1:GAIN? 230.00
Query Format	SYSTem:AIO:INput[n]:GAIN:DEFAult?
Description	Returns the default full-scale gain for the specified analog input.
Parameters	None
Returned Data Format	<nr2>
Query Example	SYST:AIO:IN1:GAIN:DEF? 300.0
Query Format	SYSTem:AIO:INput[n]:GAIN:MAXimum?
Description	Returns the maximum full-scale gain for the specified analog input.
Parameters	None
Returned Data Format	n/a
Query Example	SYST:AIO:IN1:GAIN:MAX? 100000.000000
Query Format	SYSTem:AIO:INput[n]:GAIN:MINimum?
Description	Returns the minimum full-scale gain for the specified analog input.
Parameters	None
Returned Data Format	n/a
Query Example	SYST:AIO:IN1:GAIN:MIN? -100000.000000

Command Syntax	SYSTem:AIO:INput[n]:OFFSET <nr2>
Description	Sets the offset of the AFX parameter controlled by the analog input.
Parameters	Offset
Parameter Format	<nr2>
Example	SYST:AIO:IN1:OFFSET 50.0
Query Format	SYSTem:AIO:INput[n]:OFFSET?
Returned Data Format	<nr2>
Query Example	SYST:AIO:IN1:OFFSET? 15.00
Query Format	SYSTem:AIO:INput[n]:OFFSET:DEFault?
Description	Returns the default offset for the specified analog input.
Parameters	None
Returned Data Format	n/a
Query Example	SYST:AIO:IN1:OFFSET:DEF? 15.0
Query Format	SYSTem:AIO:INput[n]:OFFSET:MAXimum?
Description	Returns the maximum offset for the specified analog input.
Parameters	None
Returned Data Format	n/a
Query Example	SYST:AIO:IN1:OFFSET:MAX? 100000.000000
Query Format	SYSTem:AIO:INput[n]:OFFSET:MINimum?
Description	Returns the minimum offset for the specified analog input.
Parameters	None
Returned Data Format	n/a
Query Example	SYST:AIO:IN1:OFFSET:MIN? -100000.000000
Command Syntax	SYSTem:AIO:INput[n]:RANGe <nr2>
Description	Sets the range of the specified analog input. Available range is 0.0 ~ 10.
Parameters	Offset
Parameter Format	<nr2>
Example	SYST:AIO:IN1:RANG 50.0
Query Format	SYSTem:AIO:INput[n]:RANGe?
Returned Data Format	<nr2>
Query Example	SYST:AIO:IN1:RANG? 10.00

Query Format	SYSTem:AIO:INput[n]:RANGe:DEFault?
Description	Returns the default range for the specified analog input.
Parameters	None
Returned Data Format	n/a
Query Example	SYST:AIO:IN1:RANG:DEF? 0.0
Query Format	SYSTem:AIO:INput[n]:RANGe:MAXimum?
Description	Returns the maximum range for the specified analog input.
Parameters	None
Returned Data Format	n/a
Query Example	SYST:AIO:IN1:RANG:MAX? 10.0
Query Format	SYSTem:AIO:INput[n]:RANGe:MINimum?
Description	Returns the minimum range for the specified analog input.
Parameters	None
Returned Data Format	n/a
Query Example	SYST:AIO:IN1:RANG:MIN? 0.0
Query Format	SYSTem:AIO:INput[n]:UNITs?
Description	Returns the assigned unit for the specified analog input port.
Parameters	None
Returned Data Format	<cr>
Query Example	SYST:AIO:IN2:UNIT? Vrms
Query Format	SYSTem:AIO:INput[n]:VOLTage?
Description	Returns the voltage value at the specified analog input port.
Parameters	None
Returned Data Format	<nr2>
Query Example	SYST:AIO:IN2:VOLT? 4.895

8.10.1.2 SYSTem:AIO:OUTput

Command Syntax	SYSTem:AIO:OUTput[n] <cr>
Description	Sets the AFX measurement that is mapped to each analog output port.
Parameters	[MEAS:CURR1? MEAS:CURR2? MEAS:CURR3? MEAS:CURR:CREST1? MEAS:CURR:CREST2? MEAS:CURR:CREST3? MEAS:CURR:CREST? MEAS:CURR:DC1? MEAS:CURR:DC2? MEAS:CURR:DC3? MEAS:CURR:DC? MEAS:CURR:PEAK1? MEAS:CURR:PEAK2? MEAS:CURR:PEAK3? MEAS:CURR:PEAK? MEAS:CURR? MEAS:FREQ? MEAS:KVA1? MEAS:KVA2? MEAS:KVA3? MEAS:KVA? MEAS:PF1? MEAS:PF2? MEAS:PF3? MEAS:PF? MEAS:POW1? MEAS:POW2? MEAS:POW3? MEAS:POW? MEAS:VLL:AC1? MEAS:VLL:AC2? MEAS:VLL:AC3? MEAS:VLL:AC? MEAS:VLL:ACDC1? MEAS:VLL:ACDC2? MEAS:VLL:ACDC3? MEAS:VLL:ACDC? MEAS:VLL:DC1? MEAS:VLL:DC2? MEAS:VLL:DC3? MEAS:VLL:DC? MEAS:VOLT:AC1? MEAS:VOLT:AC2? MEAS:VOLT:AC3? MEAS:VOLT:AC? MEAS:VOLT:ACDC1? MEAS:VOLT:ACDC2? MEAS:VOLT:ACDC3? MEAS:VOLT:ACDC? MEAS:VOLT:DC1? MEAS:VOLT:DC2? MEAS:VOLT:DC3? MEAS:VOLT:DC?] See the “SYSTem:AIO:OUTput:CATalog?” command for a list of available parameters.
Parameter Format	<cr>
Example	SYST:AIO:OUT1 VRMS
Query Format	SYSTem:AIO:OUTput[n]?
Returned Data Format	<cr>
Query Example	SYST:AIO:OUTP? VRMS
Query Format	SYSTem:AIO:OUTput:CATalog?
Description	Returns list of available analog outputs
Returned Data Format	<cr>
Query Example	SYST:AIO:OUT:CAT? MEAS:CURR1?,MEAS:CURR2?,MEAS:CURR3?,MEAS:CURR:CREST1?,MEAS:CURR:CREST2?,MEAS:CURR:CREST3?,MEAS:CURR:CREST?,MEAS:CURR:DC1?,MEAS:CURR:DC2?,MEAS:CURR:DC3?,MEAS:CURR:DC?,MEAS:CURR:PEAK1?,MEAS:CURR:PEAK2?,MEAS:CURR:PEAK3?,MEAS:CURR:PEAK?,MEAS:CURR?,MEAS:FREQ?,MEAS:KVA1?,MEAS:KVA2?,MEAS:KVA3?,MEAS:KVA?,MEAS:PF1?,MEAS:PF2?,MEAS:PF3?,MEAS:PF?,MEAS:POW1?,MEAS:POW2?,MEAS:POW3?,MEAS:POW?,MEAS:VLL:AC1?,MEAS:VLL:AC2?,MEAS:VLL:AC3?,MEAS:VLL:AC?,MEAS:VLL:ACDC1?,MEAS:VLL:ACDC2?,MEAS:VLL:ACDC3?,MEAS:VLL:ACDC?,MEAS:VLL:DC1?,MEAS:VLL:DC2?,MEAS:VLL:DC3?,MEAS:VLL:DC?,MEAS:VOLT:AC1?,MEAS:VOLT:AC2?,MEAS:VOLT:AC3?,MEAS:VOLT:AC?,MEAS:VOLT:ACDC1?,MEAS:VOLT:ACDC2?,MEAS:VOLT:ACDC3?,MEAS:VOLT:ACDC?,MEAS:VOLT:DC1?,MEAS:VOLT:DC2?,MEAS:VOLT:DC3?,MEAS:VOLT:DC?

Command Syntax	SYSTem:AIO:OUTput[n]:GAIN <nr2>
Description	Sets the full-scale gain of the AFX measurement mapped to the analog input.
Parameters	Full scale value
Parameter Format	<nr2>
Example	SYST:AIO:OUT1:GAIN 230.0
Query Format	SYSTem:AIO:OUTput[n]:GAIN?
Returned Data Format	<nr2>
Query Example	SYST:AIO:OUT1:GAIN? 425.0000
Query Format	SYSTem:AIO:OUTput[n]:GAIN:DEFault?
Description	Returns the default full-scale gain for the specified analog output port.
Parameters	None
Returned Data Format	n/a
Query Example	SYST:AIO:OUT1:GAIN:DEF? 425.0000
Query Format	SYSTem:AIO:OUTput[n]:GAIN:MAXimum?
Description	Returns the maximum gain for the specified analog output port.
Parameters	None
Returned Data Format	n/a
Query Example	SYST:AIO:OUT1:GAIN:MAX? 100000.00000
Query Format	SYSTem:AIO:OUTput[n]:GAIN:MINimum?
Description	Returns the minimum gain for the specified analog output port.
Parameters	None
Returned Data Format	n/a
Query Example	SYST:AIO:OUT1:GAIN:MIN? -100000.00000
Command Syntax	SYSTem:AIO:OUTput[n]:OFFSET <nr2>
Description	Sets the offset of the specified analog output port.
Parameters	Offset
Parameter Format	<nr2>
Example	SYST:AIO:OUT1:OFFSET 50.0
Query Format	SYSTem:AIO:OUTput[n]:OFFSET?
Returned Data Format	<nr2>
Query Example	SYST:AIO:OUT1:OFFSET? 50.00

Query Format	SYSTem:AIO:OUTput[n]:OFFSET:DEFault?
Description	Returns the default offset for the specified analog output port.
Parameters	None
Returned Data Format	n/a
Query Example	SYST:AIO:OUT1:OFFSET:DEF? 0.00000
Query Format	SYSTem:AIO:OUTput[n]:OFFSET:MAXimum?
Description	Returns the maximum gain for the specified analog output port.
Parameters	None
Returned Data Format	n/a
Query Example	SYST:AIO:OUT1:GAIN:MAX? 100000.00000
Query Format	SYSTem:AIO:OUTput[n]:OFFSET:MINimum?
Description	Returns the minimum gain for the specified analog output port.
Parameters	None
Returned Data Format	n/a
Query Example	SYST:AIO:OUT1:GAIN:MIN? -100000.00000
Command Syntax	SYSTem:AI:OUTput[n]:GAIN <nr2>
Description	Sets the full-scale gain of the specified analog output port.
Parameters	Full scale value
Parameter Format	<nr2>
Example	SYST:AIO:OUT1:GAIN 230.0
Query Format	SYSTem:AIO:OUTput[n]:GAIN?
Returned Data Format	<nr2>
Query Example	SYST:AIO:OUT1:GAIN? 230.00
Query Format	SYSTem:AIO:OUTput[n]:GAIN:DEFault?
Description	Returns the default full-scale gain for the specified analog output.
Parameters	None
Returned Data Format	<nr2>
Query Example	SYST:AIO:OUT1:GAIN:DEF? 425.00000
Query Format	SYSTem:AIO:OUTput[n]:GAIN:MAXimum?
Description	Returns the maximum full-scale gain for the specified analog output.
Parameters	None
Returned Data Format	n/a
Query Example	SYST:AIO:OUT1:GAIN:MAX? 100000.00000

Query Format	SYSTem:AIO:OUTput[n]:GAIN:MINimum?
Description	Returns the minimum full-scale gain for the specified analog output.
Parameters	None
Returned Data Format	n/a
Query Example	SYST:AIO:OUT1:GAIN:MIN? -100000.00000

Query Format	SYSTem:AIO:OUTput[n]:UNITs?
Description	Returns the assigned unit for the specified analog output port.
Parameters	None
Returned Data Format	<cr>
Query Example	SYST:AIO:OUT2:UNIT? Vrms

Query Format	SYSTem:AIO:OUTput[n]:VOLTage?
Description	Returns the voltage at the analog output port.
Parameters	None
Returned Data Format	<nr2>
Query Example	SYST:AIO:OUT2:VOLT? 7.2590

8.10.1.3 SYSTem:DIO:Input

Query Format	SYSTem:DIO:INput[n]?
Description	Queries status of Digital Input 1, 2 or 3. If I/O number is omitted, all three input values are returned. n = 1, 2 or 3.
Parameters	none
Returned Data Format	<cr>
Parameter Format	<nr1>
Query Example	SYST:DIO:IN2? 0

Command Syntax	SYSTem:DIO:INput[n]:FALLing <cr>
	SYSTem:DIO:INput[n]:RISing <cr>
Description	Sets the SCPI command to be executed at the rising or falling event of that digital input [n]. n = 1, 2 or 3.
Parameters	SCPI command string
Parameter Format	<cr>
Example	SYST:DIO:IN1:FALL "OUTP 0" SYST:DIO:IN1:RIS "OUTP 1" These settings will enable the output at the rising edge of the pulse and disable it at the falling edge.
Query Format	SYSTem:DIO:INput[n]:FALLing? SYSTem:DIO:INput[n]:RISing?
Returned Data Format	<cr>
Query Example	SYST:DIO:IN1:RIS? OUTP 1 SYST:DIO:IN1:FALL? -
Command Syntax	SYSTem:DIO:INput[n]:FILtersize <nr1>
Description	Defines the time in ms (milliseconds) that the digital input has to keep the state after a transition in order to generate the event. If filtersize is zero, then the event is immediately generated, otherwise the specified time will prevent short pulses from generating events. This is useful in noisy environments and also if the digital signal is controlled by a switch or a mechanical actuator.
Parameters	0 – 1000
Parameter Format	<nr1>
Example	SYST:DIO:IN1:FIL 8
Query Format	SYSTem:DIO:INput[n]:FILtersize?
Returned Data Format	<nr1>
Query Example	SYST:DIO:IN1:FIL? 8
Query Format	SYSTem:DIO:INput[n]:FILtersize:DEFault?
Description	Returns the default filter size value.
Returned Data Format	<nr1>
Query Example	SYST:DIO:IN1:FIL:DEF? 0
Query Format	SYSTem:DIO:INput[n]:FILtersize:MAXimum?
Description	Returns the maximum allowed filter size value.
Returned Data Format	<nr1>
Query Example	SYST:DIO:IN1:FIL:MAX? 1000

Query Format	SYSTem:DIO:INput[n]:FILtersize:MINimum?
Description	Returns the minimum allowed filter size value.
Returned Data Format	<nr1>
Query Example	SYST:DIO:IN1:FIL:MIN? 1

8.10.1.4 SYSTem:DIO:OUTput

Command Syntax	SYSTem:DIO:OUTput[n] <MODE>
Description	Sets output value of digital output n. n = 1 or 2.
Parameter 1	MODE The mode determines when an output is generated. Available MODE settings are: <ul style="list-style-type: none"> • 1, ON, 0, OFF it is used as general purpose output. [0 LOW 1 HIGH] • OUTPUT_STATE indicates output enabled(1) or disabled(0). • FORM indicates single(1) or split/three(0). • FAULT indicates fault(1) or no fault(0). • TRANSIENT indicates when a transient is running/paused/stepping(1) or stopped(0). • PROGRAM indicates when a program is in execution at steady state level(1) or manual mode(0). • REMOTE indicates remote(1) or local(0) state Defaults are: OUTPUT1: OUTPUT_STATE OUTPUT2: FORM
Parameter Format	<cr>
Example	SYST:DIO:OUT1 FAULT
Query Format	SYSTem:DIO:OUTput[n]?
Description	Returns settings for selected pin number n
Returned Data Format	<nr1>
Query Example	SYST:DIO:OUT1? OUTPUT STATE,NON-INVERTING
Query Format	SYSTem:DIO:OUTput:CATalog?
Description	Returns list of available digital outputs
Returned Data Format	<cr>
Query Example	SYST:DIO:OUT:CAT? COUPLING,FAULT,FORM,HIGH,LOW,OUTPUT STATE,PROGRAM,REMOTE,TRANSIENT

Command Syntax	SYSTem:DIO:OUTput[n]:INVert
Description	Inverts the logic polarity of the selected digital output.
Parameters	[0 NORMAL 1 INVERT]
Example	SYST:DIO:OUT1 1
Query Format	SYSTem:DIO:OUTput[n]:INVert?
Description	Returns logic inversion setting
Returned Data Format	<nr1>
Query Example	SYST:DIO:OUT1:INV? 1

Query Format	SYSTem:DIO:OUTput[n]:STATe?
Description	Returns logic level of selected output pin.
Returned Data Format	
Query Example	SYST:DIO:OUT1:STAT? 1

8.10.1.5 SYSTem:DIO:REMOte

Command Syntax	SYSTem:DIO:REMOte:ENABle
Description	Turns the remote enable state on or off
Parameters	< 0 OFF 1 ON >
Parameter Format	
Example	SYST:DIO:REMOte:ENABle 1
Query Format	SYSTem:DIO:REMOte:ENABle?
Returned Data Format	
Query Example	SYST:DIO:REM:ENA? 1

Command Syntax	SYSTem:DIO:REMOte:ENABle:AUTO
Description	Enables or Disables the Remote Input function at power on. By default, on a regular AFX/ADF it is 1 for backward compatibility. When it is 1 it enables the output immediately when remote enable is set to 1 or when the unit boots. A warning will be displayed on the LCD and a beep will sound before the output enables. When it is 0 it only enables the output when it detects a 0 to 1 change in the input and disables the output with a 1 to 0. Both settings can be changed by the user. Sending a sanitize command returns this setting back to 1 and 0 respectively. Note: This command requires firmware rev 2.2.28 or higher.

Parameters	< 0 OFF 1 ON >
Parameter Format	
Example	SYST:DIO:REMOte:ENABle:AUTO 1
Query Format	SYSTem:DIO:REMOte:ENABle:AUTO?
Returned Data Format	
Query Example	SYST:DIO:REM:ENA:AUTO? 1

Command Syntax	SYSTem:DIO:REMOte:INHibit
Description	Turns the remote inhibit state on or off
Parameters	< 0 OFF 1 ON >
Parameter Format	
Example	SYST:DIO:REMOte:INHibit 1
Query Format	SYSTem:DIO:REMOte:INHibit?
Returned Data Format	
Query Example	SYST:DIO:REM:INH? 1

8.10.1.6 SYSTem:DIO:STROBE

Command Syntax	SYSTem:DIO:STROBE:OUTPustate
Description	Sets the function strobe mode active when the output relay changes state
Parameters	< 0 OFF 1 ON >
Parameter Format	
Example	SYST:DIO:STROBE:OUTP 1
Query Format	SYSTem:DIO:STROBE:OUTPustate?
Returned Data Format	
Query Example	SYST:DIO:STROBE:OUTP? 1

Command Syntax	SYSTem:DIO:STROBE:SOURce
Description	Sets the function strobe mode to program changes.
Parameters	< 0 OFF 1 ON >
Parameter Format	
Example	SYST:DIO:STROBE:SOUR 1
Query Format	SYSTem:DIO:STROBE:SOURce?
Returned Data Format	
Query Example	SYST:DIO:STROBE:SOUR? 1

Command Syntax	SYSTem:DIO:STROBE:TRANsient
Description	Sets the function strobe mode to generate an output at the start of a transient execution.
Parameters	< 0 OFF 1 ON >
Parameter Format	
Example	SYST:DIO:STROBE:TRAN 1
Query Format	SYSTem:DIO:STROBE:TRANsient?
Returned Data Format	
Query Example	SYST:DIO:STROBE:TRAN? 1

8.10.2 SOURce:SYNChronize Commands

```
SOURce:SYNChronize
    [:INput][?]
        :PHASEshift[?]
        :RANGE[?]
        :SOURCE[?]
        :SPeed[?]
        :STATe?

SOURce:SYNChronize
    :OUTPut[?]
```

8.10.2.1 SOURce:SYNChronize[:INput]

Command Syntax	SOURce:SYNChronize[:INput]
Description	This command enables or disables the external sync input mode.
Parameters	[0 OFF 1 ON]
Parameter Format	
Example	SOUR:SYNC 1
Query Format	SOURce:SYNChronize[:INput]?
Returned Data Format	
Query Example	SOUR:SYNC? 1

Command Syntax	SOURce:SYNChronize[:Input]:PHASEshift <nr2>
Description	Defines a fixed phase shift between phase A waveform generation and the external sync source. Used to calibrate any phase difference between the sync signal and the power source output on phase A.
Parameters	Phase shift
Parameter Format	<nr>
Example	SOUR:SYNC:PHASE 2.8
Query Format	SOURce:SYNChronize[:Input]:PHASEshift?
Returned Data Format	<nr2>
Query Example	SOUR:SYNC:PHASE? 0.5

<p>Command Syntax Description</p>	<p>SOURce:SYNChronize[:Input]:RANGe <nr2> Allows configuration of how much the synchronization engine is able to deviate from the AFX programmed frequency. This helps to keep the waveform frequency under control, even if the external source is not present all the time. The synchronization engine is limited to frequencies of FSETPOINT +/- FRANGE.</p>
<p>Parameters Parameter Format Example Query Format Returned Data Format Query Example</p>	<p>Range in Hz <nr2> SOUR:SYNC:RANG 5.0 SOURce:SYNChronize[:Input]:RANGe? <nr2> SOUR:SYNC:RANGe? 10.000</p>
<p>Command Syntax Description</p>	<p>SOURce:SYNChronize[:Input]:SOURce <cr> This command selects either the external sync TTL (1) or the internal AC line sync (0) mode. The internal AC sync signal is derived from the power sources three phase L-L voltages so a phase adjustment for Phase A output will be needed using the SOURce:SYNChronize[:Input]:PHASEshift command.</p>
<p>Parameters Parameter Format Example Query Format Returned Data Format Query Example</p>	<p>[0 AC 1 TTL] <cr> SOUR:SYNC:SOUR TTL SOURce:SYNChronize[:Input]:SOURce? <cr> SOUR:SYNC:SOUR? 1</p>
<p>Command Syntax Description</p>	<p>SOURce:SYNChronize[:Input]:SPeEd <nr2> Allows accelerating the speed of the internal synchronization engine (PLL) in case the external sync source is not constant and presents periodic or continuous changes. A slower speed improves the stability of the waveform frequency, so it is recommended to keep use the smallest possible speed values.</p>
<p>Parameters Parameter Format Example Query Format Returned Data Format Query Example</p>	<p>Speed (multiplier value) <nr1> Range is 1.000 ~ 10.000 SOUR:SYNC:SP 0.50 SOURce:SYNChronize[:Input]:SPeEd? <nr2> SOUR:SYNC:SP? 2.500</p>

Query Command	SOURce:SYNChronize[:Input]:STATe?
Description	This query only command returns the status of the Phase Lock Loop (PLL). A "0" response indicates the PLL has not locked on to the sync input yet. A 1 response indicates the PLL is locked.
Returned Data Format	
Returned Data	0 = PLL is not locked 1 = PLL is locked
Query Example	SOUR:SYNC:STAT? 1

8.10.2.2 SOURce:SYNChronize[:OUTput]

Command Syntax	SOURce:SYNChronize:OUTput
Description	This command enables the SYNC output
Query Format	SOURce:SYNChronize:OUTput?
Returned Data Format	
Returned Data	0 = SYNC output off 1 = SYNCoutput on
Query Example	SOUR:SYNC:OUT? 1

8.10.3 PROGram:TRANSient Triggers Commands

```

PROGram:TRANSient:TRIGger
    :Input[?]
        :IMMEDIATE[?]
        :AUTOrun[?]

    :OUTput[?]
    
```

8.10.3.1 PROGram:TRANSient

The following **PROGram:TRANSient:TRIGger** commands are available.

Command Syntax	PROGram:TRANSient:TRIGger:INput
Description	When the trigger input is active, this command selects the trigger input source mode as on or off. When ON, the external trigger input is enabled.
Parameters	[0 OFF 1 ON]
Parameter Format	
Example	PROG:TRAN:TRIG:IN 1
Query Format	PROGram:TRANSient:TRIGger:INput?
Returned Data Format	
Query Example	PROG:TRAN:TRIG:IN? 1
Command Syntax	PROGram:TRANSient:TRIGger:INput:IMMEDIATE
Description	When the trigger input is active, this command starts the transient segments immediately after the trigger input is received, without waiting for the zero crossing, as determined by the update phase setting. Refer to SOURce:UPDATEPHase
Parameters	[0 OFF 1 ON]
Parameter Format	
Example	PROG:TRAN:TRIG:IN:IMM 1
Query Format	PROGram:TRANSient:TRIGger:INput:IMMEDIATE?
Returned Data Format	
Query Example	PROG:TRAN:TRIG:IN:IMM? 1

Command Syntax Description	PROG:TRANSient:TRIGger:INput:AUTOrun When the trigger input is active and segments are running state, each trigger event (pulse) will automatically start a new sequence, without the need of a new RUN command before each trigger. The RUN command has to be executed only once, and then each subsequent trigger input event will cause a new segment sequence to run. Note: the trigger signal is level-sensitive; hence if it is kept high, it will continuously issue a trigger.
Parameters Parameter Format Example Query Format Returned Data Format Query Example	[0 OFF 1 ON] PROG:TRAN:TRIG:IN:AUTO 1 PROG:TRANSient:TRIGger:INput:AUTOrun? PROG:TRAN:TRIG:IN:AUTO? 1
Command Syntax Description	PROG:TRANSient:TRIGger:OUTput This command causes a trigger output pulse to be generated when a transient execution is started. Note that this output is used as a function strobe during steady state operation.
Parameters Parameter Format Example Query Format Returned Data Format Query Example	[0 OFF 1 ON] PROG:TRAN:TRIG:OUT 1 PROG:TRANSient:TRIGger:OUTput? PROG:TRAN:TRIG:OUT? 1

8.10.4 AUX I/O Calibration Commands

```

SYSTem:AIO
  :INPut#
    :CALibration
      :GAIN{?}
        :DEFault{?}
        :MAXimum
        :MINimum
      :OFFset{?}
        :DEFault{?}
        :MAXimum
        :MINimum
  :OUTput#
    :CALibration
      :GAIN{?}
        :DEFault{?}
        :MAXimum
        :MINimum
      :OFFset{?}
        :DEFault{?}
        :MAXimum
        :MINimum

```

8.10.4.1 SYSTem:AIO:INPut#:CALibration

Command Syntax	SYSTem:AIO:INput[n]:CALibration:GAIN <nr2>
Description	Calibrates the full scale gain of the AFX parameter controlled by the analog input.
Parameters	Reference
Parameter Format	<nr2>
Example	SYST:AIO:IN1:CAL:GAIN 100.0
Query Format	SYSTem:AIO:INput[n]:CALibration:GAIN?
	Returns calibration coefficient
Returned Data Format	<nr2>
Query Example	SYST:AIO:IN1:CAL:GAIN? 1.000
Query Command	SYSTem:AIO:INput[n]:CALibration:GAIN:DEFault?
	Returns default calibration coefficient value
Returned Data Format	<nr2>
Query Example	SYST:AIO:IN1:CAL:GAIN:DEF? 1.000
Query Command	SYSTem:AIO:INput[n]:CALibration:GAIN:MAXimum?
	Returns upper limit of calibration coefficient value
Returned Data Format	<nr2>
Query Example	SYST:AIO:IN1:CAL:GAIN:MAX? 1.000

Query Command	SYSTem:AIO:INput[n]:CALibration:GAIN:MINimum? Returns lower limit of calibration coefficient value
Returned Data Format	<nr2>
Query Example	SYST:AIO:IN1:CAL:GAIN:MIN? 0.000
Command Syntax Description	SYSTem:AIO:INput[n]:CALibration:OFFset <nr2> Calibrates the full scale gain of the AFX parameter controlled by the analog input.
Parameters	Reference
Parameter Format	<nr2>
Example	SYST:AIO:IN1:CAL:OFF 0.01
Query Format	SYSTem:AIO:INput[n]:CALibration:OFFset? Returns calibration coefficient
Returned Data Format	<nr2>
Query Example	SYST:AIO:IN1:CAL:OFF? 0.010
Query Command	SYSTem:AIO:INput[n]:CALibration:OFFset:DEFault? Returns default calibration coefficient value
Returned Data Format	<nr2>
Query Example	SYST:AIO:IN1:CAL:OFF:DEF? 1.000
Query Command	SYSTem:AIO:INput[n]:CALibration:OFFset:MAXimum? Returns upper limit of calibration coefficient value
Returned Data Format	<nr2>
Query Example	SYST:AIO:IN1:CAL:OFF:MAX? 1.000

Query Command	SYSTem:AIO:INput[n]:CALibration:OFFset:MINimum? Returns lower limit of calibration coefficient value
Returned Data Format	<nr2>
Query Example	SYST:AIO:IN1:CAL:OFF:MIN? 1.000

8.10.4.2 SYSTem:AIO:OUTput#:CALibration

Command Syntax	SYSTem:AIO:OUTput[n]:CALibration:GAIN <nr2>
Description	Calibrates the full scale gain of the AFX parameter controlled by the analog output.
Parameters	Reference
Parameter Format	<nr2>
Example	SYST:AIO:OUT1:CAL:GAIN 100.0
Query Format	SYSTem:AIO:OUTput[n]:CALibration:GAIN? Returns calibration coefficient
Returned Data Format	<nr2>
Query Example	SYST:AIO:OUT1:CAL:GAIN? 1.000

Query Command	SYSTem:AIO:OUTput[n]:CALibration:GAIN:DEFault? Returns default calibration coefficient value
Returned Data Format	<nr2>
Query Example	SYST:AIO:OUT1:CAL:GAIN:DEF? 1.000

Query Command	SYSTem:AIO:OUTput[n]:CALibration:GAIN:MAXimum? Returns upper limit of calibration coefficient value
Returned Data Format	<nr2>
Query Example	SYST:AIO:OUT1:CAL:GAIN:MAX? 1.000

Query Command	SYSTem:AIO:OUTput[n]:CALibration:GAIN:MINimum? Returns lower limit of calibration coefficient value
Returned Data Format	<nr2>
Query Example	SYST:AIO:OUT1:CAL:GAIN:MIN? 0.000

Command Syntax	SYSTem:AIO:OUTput[n]:CALibration:OFFset <nr2>
Description	Calibrates the full scale gain of the AFX parameter controlled by the analog output.
Parameters	Reference
Parameter Format	<nr2>
Example	SYST:AIO:OUT1:CAL:OFF 0.01
Query Format	SYSTem:AIO:OUTput[n]:CALibration:OFFset?
	Returns calibration coefficient
Returned Data Format	<nr2>
Query Example	SYST:AIO:OUT1:CAL:OFF? 0.010
Query Command	SYSTem:AIO:OUTput[n]:CALibration:OFFset:DEFault?
	Returns default calibration coefficient value
Returned Data Format	<nr2>
Query Example	SYST:AIO:OUT1:CAL:OFF:DEF? 1.000
Query Command	SYSTem:AIO:OUTput[n]:CALibration:OFFset:MAXimum?
	Returns upper limit of calibration coefficient value
Returned Data Format	<nr2>
Query Example	SYST:AIO:OUT1:CAL:OFF:MAX? 1.000
Query Command	SYSTem:AIO:OUTput[n]:CALibration:OFFset:MINimum?
	Returns lower limit of calibration coefficient value
Returned Data Format	<nr2>
Query Example	SYST:AIO:OUT1:CAL:OFF:MIN? 1.000

8.11 Web Browser Test Sequence Commands

The following SCPI commands are available to control Power source embedded Test Sequence operation from an user ATE test program. **Note** that the Test Sequence functionality requires power source firmware revision 3.7.0 or higher.

Command Syntax Description	TSEquence:CATalog? Returns a comma-separated list of available sequences files. The query can be customized with the type of memory, OFFSET to determine start index, and LENGTH to define the number of results. <OPT: MEMORY, OPT: OFFSET, OPT: LENGTH>
Parameters	Memory types: INTERNAL RAM INTERNAL = Internal Flash Memory. (Default selection) RAM = Internal RAM. Content will be lost when power source is turned off.
Parameter Format	<cr>, <nr1>, <nr1>
Returned Data Format	<cr>
Example	TSEQ:CAT? 1,"4-11-Dips-Class2-Test.7z",2,"4-11-Dips-Class3-Test.7z",3,"4-11-Short-Interruptions-Test.7z",4,"4-11-Vars-Test.7z" TSEQ:CAT? RAM 1,"TestExample.7z" TSEQ:CAT? INTERNAL, 3, 4 3,"4-11-Short-Interruptions-Test.7z",4,"4-11-Vars-Test.7z"
Command Syntax Description Parameters	TSEquence:SElect This command selects a sequence file by name or number. <REQ: FILE STRING FILE NUMBER, OPT: MEMORY> Memory types: INTERNAL RAM INTERNAL = Internal Flash Memory. (Default selection) RAM = Internal RAM. Content will be lost when power source is turned off.
Parameter Format	<cr> or <nr1>, <cr>
Example	TSEQ:SEL "TestExample.7z", RAM TSEQ:SEL 3, INTERNAL TSEQ:SEL 1
Query Format	TSEquence:SElected?
Returned Data Format	<cr>
Query Example	TSEQ:SEL? "4-11-Short-Interruptions-Test"
Command Syntax Description Parameters	TSEquence:CONTRol This command controls sequence execution <RUN PAUSE STOP STEP REStart PASS FAIL CLEAR> RUN: to start the execution from the last selected step PAUSE: to pause the execution, only available when the sequence state is running. STOP: to stop the execution. STEP: to execute only the selected step. REST: to restart all progress and test execution.

	<p>PASS: to pass the current step in execution.</p> <p>FAIL: to fail the current step in execution and stop the sequence progress.</p> <p>CLEAR: to clear all logs and remove currently selected sequence from the execution panel.</p>
Parameter Format Example	<p><cr></p> <p>TSEQ:CON RUN</p> <p>TSEQ:CON PASS</p> <p>TSEQ:CON CLEAR</p>
Command Syntax Description	<p>TSEquence:STATUS?</p> <p>This command returns sequence execution status, where:</p> <p>NUMBER: <nr1>. Current step number. Example: 1</p> <p>PROGRESS: <nr1>. Current step progress. <0> to <100></p> <p>STATUS: <cr>. Current state of the step execution:</p> <p>"0-SKIPPED"</p> <p>"1-PASSED"</p> <p>"2-FAILED"</p> <p>"3-STOPPED"</p> <p>"4-RUNNING"</p> <p>"5-PAUSED"</p> <p>DESCRIPTION: <cr>. Current step description. Example: "User Input"</p> <p>INSTRUCTION: <cr>. Returns TRUE if there is pending user input.</p> <p>Note: When an instruction is pending, some commands will not be available, for example: TSEQ:STEP:GOTO or TSEQ:CON RUN</p>
Parameters	None
Returned Data Format	<cr>
Query Example	<p>TSEQ:STAT?</p> <p>NUMBER,1,PROGRESS,0,STATUS,"4-RUNNING",DESCRIPTION,"Configuration",INSTRUCTION,TRUE</p>
Command Syntax Description	<p>TSEquence:Input</p> <p>This command allows to enter the necessary parameter when the instruction status is pending (INSTRUCTION, TRUE).</p>
Parameters	<p><REQ: VARIABLE STRING INPUT NUMBER, REQ: VALUE STRING></p> <p>Where input number is the index obtained using TSEQ:IN?. In addition, it is possible to enter each entry with its respective variable name.</p>
Parameter Format Example	<p><cr> or <nr1>, <cr></p> <p>TSEQ:IN "IEC61000_4_11_UUT_SN", "00024"</p> <p>TSEQ:IN "IEC61000_4_11_COMPANY", "PPST"</p> <p>TSEQ:IN 3, "PPST"</p>
Query Format	TSEquence:INput?
Returned Data Format	<cr>
Query Example	<p>TSEQ:IN?</p> <p>1,INPUT,"UUT Part Number",VARIABLE,"IEC61000_4_11_UUT_PN",VALUE,"1",2,INPUT,"UUT Serial Number",VARIABLE,"IEC61000_4_11_UUT_SN",VALUE,"00024",3,INPU</p>

```
T,"Company
Name",VARIABLE,"IEC61000_4_11_COMPANY",VALUE,"",4,INPUT,"Tes
t Operator",VARIABLE,"IEC61000_4_11_TECH",VALUE,"",5,INPUT,"UUT
Mode of
Operation",VARIABLE,"IEC61000_4_11_UUT_OP_MODE",VALUE,""
```

Command Syntax	TSEquence:RESULT?
Description	Returns a comma-separated list of all steps in the sequence with their respective status.
Parameters	None
Parameter Format	n/a
Returned Data Format	<cr>
Example	TSEQ:RES? 1,PASSED,2,PASSED,3,SKIPPED,4,STOPPED,5,-,6,-,7,-,8,-,9,-,10,-,11,-,12,-,13,-,14,-,15,-,16,-,17,-,18,-,19,-,20,-,21,-,22,-,23,-,24,-,25,-

Command Syntax	TSEquence:STEP:GOTO
Description	This command moves the execution cursor to the argument of the element passed.
Parameters	<REQ: STEP NUMBER>
Parameter Format	<nr1>
Returned Data Format	n/a
Query Example	TSEQ:STEP:GOTO 1 TSEQ:STEP:GOTO 3 TSEQ:STEP:GOTO 10

8.12 AFXS Series Mode Commands

These commands apply to AFXS Model master power source models only. The “S” option designation is part of the Model number returned by the *IDN? Query command. Standard units return 3150AFX whereas units configured with the Series mode option return “3150AFXS”.

Command Syntax	SOURce:SERIES < 0 OFF 1 ON >
Description	Turns Series output mode ON or OFF. This command can be changed as long as the series modes was configured with SYSTem:SERIESconnection 600. This command allows switching between high voltage/low current or low voltage/high current modes if the SPMS is present. <ul style="list-style-type: none"> • OFF or 0 = All AFXs in parallel • ON or 1 = AFXs in series Without the SPMS option, the user has to ensure that this command matches the wiring (parallel or series depending on customer requirement) before changing modes.
Parameters	< 0 OFF 1 ON >
Parameter Format	 or <cr>
Example	SOUR:SERIES ON
Query Format	SOURce:SERIES?
Returned Data Format	Returns series setting mode
Query Example	<nr1> SOUR:SERIES? 1

Command Syntax Description	SOURce:SERIES:PROTection < 0 OFF 1 ON > Useful only with external SPMS switch circuit. Without, it cannot be set to 1. The default for this is ON when the series unit is configured with the SPMS switch. When ON and the inhibit input state (digital input 3) is a logical 1, it does not allow to the "SOURCE:SERIES 1" command. When OFF, it allows it, no matter the value of the digital input 3. In this case, the digital input 3 can be used for any other purpose by the user. If ON, digital input 3 cannot be used for other purposes, it's function is fixed to series inhibit.
Parameters	< 0 OFF 1 ON >
Parameter Format	 or <cr>
Example	SOUR:SERIES:PROT ON
Query Format	SOURce:SERIES:PROT? Returns protection setting
Returned Data Format	<nr1>
Query Example	SOUR:SERIES:PROT? 1
Query Command	SYSTem:SERIESUNITS? This command returns 1 if SOURCE:SERIES is set to 0/OFF. It returns 2 if SOURCE:SERIES is set 1/ON. No matter the number of units. Note: This command does NOT return the number of AFX's connected in series. To determine the actual number of units, use the SYSTem:CONNECTEDUNITS? Command instead. For a Series or Series/Parallel system, if SOURCE:SERIES is 0/OFF, it returns the total units, same as a parallel only system. If SOURCE:SERIES is 1, it returns the total number units divided by two. Refer also to the SYSTem:PARALLELUNITS? Command. SYSTem:CONNECTEDUNITS? returns the total units no matter the value of SOURCE:SERIES?. This is equal to SYSTem:SERIESUNITS? * SYSTem:PARALLELUNITS?
Returned Data Format	<nr1>
Query Example	SYST:SERIESUNITS? 2

Command Syntax Description	<p>SYSTEM:SERIESconnection <VOLTAGE, OPT: OPTIONS ></p> <p>This is used to configure the AFXS system. For AFXS systems with the SPMS option, this is done at the factory. For system integrators that connect their own AFXS system, contact factory for support.</p> <p>VOLTAGE should be 600 for series capable systems and 0 for non-series capable systems.</p> <p>OPTIONS is a 32 bits word, for now only the first 2 bits are used:</p> <ul style="list-style-type: none"> • Bit 0 is used to indicate the SPMS option is present. 1 = indicates SPMS option, 0 = no SPMS option. • Bit 1 is for protection blocked, when set to 1, this will force the SOURCE:SERIES:PROTECTION command to always ON so it cannot be set to OFF. • All other bits are reserved. <p>For example for an AFXS system with external SPMS circuit, set "SYSTEM:SERIESconnection 600,1"</p> <p>For manual output wiring changes (i.e. no SPMS hardware), set to "SYSTEM:SERIESconnection 600" or "SYSTEM:SERIESconnection 600,0"</p> <p>The external circuits are contained in the SPMS Option and allow automatic parallel or series connection changes via SCPI command or GUI.</p>
Parameters	<VOLTAGE, OPT: OPTIONS>
Parameter Format	 or <cr>
Example	SYST:SERIES 600,1
Query Format	SYSTEM:SERIESconnection?
	Returns protection setting
Returned Data Format	<nr1>
Query Example	SYST:SERIES? 600.000,0,0.0000000000,0

Multi Unit System Configuration Command Examples:

30kVA Parallel Only AFX System	30kVA Series/Parallel AFSX System
SOURCE:SERIES 0	SOURCE:SERIES 1
SYSTEM:SERIESUNITS? = 1	SYSTEM:SERIESUNITS? = 2
SYSTEM:PARALLELUNITS? = 2	SYSTEM:PARALLELUNITS? = 1
SYSTEM:CONNECTEDUNITS? = 2	SYSTEM:CONNECTEDUNITS? = 2

60kVA Parallel Only AFX System	60kVA Series/Parallel AFSX System
SOURCE:SERIES 0	SOURCE:SERIES 1
SYSTEM:SERIESUNITS? = 1	SYSTEM:SERIESUNITS? = 2
SYSTEM:PARALLELUNITS? = 4	SYSTEM:PARALLELUNITS? = 2
SYSTEM:CONNECTEDUNITS? = 4	SYSTEM:CONNECTEDUNITS? = 4

8.13 IEEE488.2 Common Commands

The following IEEE488.2 common commands (a.k.a. star commands) are supported by the AC power source. These commands are provided for compatibility with the IEEE488.2 standard. They are aliases to the relevant proprietary command and can be used interchangeably. Commands are shown in alphabetical order.

IEEE488.2 Command	Description	Group	Mandatory
*CLS	Clear Status	Status and Event	Yes
*DCL	Device Clear	Internal Operations	
*ESE <n>	Event Status Register Enable	Status and Event	Yes
*ESE?	ESE Query	Status and Event	Yes
*ESR?	Event Status Register Query	Status and Event	Yes
*GTL	Goto Local	Control	
*IDN?	Identify	System Data	Yes
*LLO	Local Lock Out	Control	Yes
*OPC	Operation Complete	Synchronization	Yes
*OPC?	OPC Status Query	Synchronization	Yes
*RST	Reset	Internal Operations	Yes
*SRE	Service Request Enable	Status and Event	Yes
*SRE?	SRE Query	Status and Event	Yes
*STB?	Status Byte Query	Status and Event	Yes
*TRG	Trigger	Synchronization	
*WAI	Wait	Synchronization	Yes

Table 8-3: Mandatory IEEE488.2 Common Commands

Command Syntax	*CLS
Description	Clear Status. The Clear Status (CLS) command clears the status byte by emptying the error queue and clearing all the event registers including the Data Questionable Event Register, the Standard Event Status Register, the Standard Operation Status Register and any other registers that are summarized in the status byte.
Command Syntax	*DCL
Description	Device Clear. Resets the instrument to a default state.
Parameters	None
Parameter Format	n/a

Command Syntax Description	*ESE<nr1> Selects the desired bits from the standard event status enable register. The variable <nr1> represents the sum of the bits that will be enabled. This register monitors I/O errors and synchronization conditions such as operation complete, request control, query error, device dependent error, status execution error, command error and power on. The selected bits are OR'd to become a summary bit (bit 5) in the byte register which can be queried. The setting by this command is not affected by *RST. However, cycling the power will reset this register to zero. Refer to section 8.14 for register bit values.
Parameters Parameter Format Example Query Format Returned Data Format Query Example	Range 0-255 <nr1> *ESE 128 *ESE? <nr1> *ESE? 193
Query Format Description	*ESR? Event Status Register Query. Reads the contents of the Status Event Register (ESR). After this query, the content of the ESR register is reset. Refer to section 8.14 for register bit values.
Returned Data Format Query Example	<nr1> *ESR? 0
Command Syntax Description Returned Data Format Query Example	*GTL Goto Local. Releases lock of front panel controls. N/A N/A
Query Format Description	*IDN? Identification Query. Returns the unit's Identity string. The IDN string response contains several fields separated by a comma. <i>Query response:</i> Manufacturer, model, serial number, firmware revision.
Returned Data Format Query Example	<cr>,<cr>,<nr1>,<nr2> *IDN? PPSC,3150AFX-2AG,106378889,2.0.0
Command Syntax Description Parameters Parameter Format	*LLO Local Lock out. Locks out front panel LOCAL function. None n/a

Command Syntax Description	*OPC The Operation Complete (OPC) command sets bit 0 in the Standard Event Status Register when all pending operations have finished.
Parameters Example Query Format Description	Optional: < BLOCK 0 NOBLOCK 1> *OPC *OPC? < BLOCK 0 NOBLOCK 1> IEEE488.2 standard command. The parameter is optional. The argument is optional, if it is not sent: <ul style="list-style-type: none"> • In UPC compatible mode default argument will be NONBLOCK or 1. • In normal mode default argument will be BLOCK or 0.
Returned Data Format Query Example	*OPC? BLOCK 0 Returns 1 when all pending overlapped operations have been completed. It can be used to cause the controller to wait for commands to complete. *OPC? NOBLOCK 1 Returns 1 if all pending overlapped operations have been completed or 0 if there are pending overlapped operations. It will not cause the controller to wait for commands to complete. Pending overlapped operations can be a transient or a soft start using ramp time/slew rates. *OPC? 1
Command Syntax Description	*SRE <nr1> Before reading a status register, bits must be enabled. This command enables bits in the service request register. The current setting is saved in non-volatile memory.
Parameters Parameter Format Example Query Format Description	0-255 <nr1> *SRE 255 *SRE? Reads the current state of the service request enable register. The register is cleared after reading it. Refer to section 8.14 for register bit values.
Returned Data Format Query Example	<nr1> *SRE? 255

Command Syntax Description	<p>*RST RESET. The *RST command (reset) has the same effect as an IEEE-488 Device Clear bus command but can be used over the RS232C, USB or LAN interface as well. This command resets the unit to its power on default state. User defined waveforms or programs are not erased but the mode is set to manual and the transient list table is cleared. (Unless there is a power-on program configured using the [SOURCE:]INITIAL command) <i>Note: A reset cycle of the power source can take up to 20 seconds to complete. When developing test programs, allow this time to pass before sending other commands. Adjust interface time-out settings as needed.</i></p>																				
Parameters	None																				
Parameter Format	n/a																				
RESET STATE	<table border="0"> <tr> <td>FORM</td> <td>3</td> <td>VOLT:MODE</td> <td>AC</td> </tr> <tr> <td>VOLT:AC</td> <td>0.0000</td> <td>COUPLING</td> <td>DC</td> </tr> <tr> <td>VOLT:DC</td> <td>0.0000</td> <td>RANGE</td> <td>AC</td> </tr> <tr> <td>CURR:AC</td> <td>41.6667</td> <td></td> <td></td> </tr> <tr> <td>CURR:DC</td> <td>20.8333</td> <td></td> <td></td> </tr> </table>	FORM	3	VOLT:MODE	AC	VOLT:AC	0.0000	COUPLING	DC	VOLT:DC	0.0000	RANGE	AC	CURR:AC	41.6667			CURR:DC	20.8333		
FORM	3	VOLT:MODE	AC																		
VOLT:AC	0.0000	COUPLING	DC																		
VOLT:DC	0.0000	RANGE	AC																		
CURR:AC	41.6667																				
CURR:DC	20.8333																				
Query Format Description	<p>*STB? Status Byte Query. The *STB? query returns the contents of the status byte register (STB). After this query, the content of the STB register is reset. Refer to section 8.14 for register bit values.</p>																				
Returned Data Format	<nr1>																				
Query Example	*STB? 4																				
Command Syntax Description	<p>*TRG Triggers pending operation.</p>																				
Parameters	None																				
Parameter Format	n/a																				
Command Syntax Description	<p>*WAI Prohibits the instrument from executing any new commands until all pending overlapped commands have been completed.</p>																				
Parameters	None																				
Parameter Format	n/a																				

8.14 Status and Events Registers

The IEEE488.2 standard defines a standardized status and events register system. Refer to the ANSI/IEEE-488.2 1987 standard for more information. This section provides an overview of these registers and bit positions for various status and error events.

8.14.1 Status Byte Register (STB)

The status register content is returned on a *STB? query. It contains 8 bits as shown in the table below. The return value represents the 8 bits positions and can range from 0-255. A *CLS command will clear the Status Byte Register (STB) and the Event Status Register (ESR). Refer to Figure 8-3, "Status Byte Logical Model".

BIT	NAME	DEFINITION
7	SOS	:STATus:OPERation register bit summary
6	MSS/RQS	- MASTER SUMMARY summarizes all STATUS BYTE bits (except bit 6) for *STB?, or, - REQUEST SERVICE indicates this device requested service when a Serial Poll was performed.
5	ESB	STANDARD EVENT STATUS REGISTER bit summary
4	MAV	MESSAGE AVAILABLE indicates Query response data is available
3	SQS	:STATus:QUESTionable register bit summary
2	EEQ	ERROR/EVENT QUEUE indicates an SCPI Error/Event message is available
1	BUSY	indicates UPC front panel not in V/I mode
0	FAULT	indicates Power Source FAULT

Table 8-4: Status Byte Register (STB)

Note: Setting a SERVICE REQUEST ENABLE (SRE) bit true unmask the STATUS bit in the STB. Bit 6 of the SRE is not applicable as the MASTER SUMMARY bit of the STB cannot be masked. The STB, SRE, ESR and ESE registers are 8 bits each.

The status byte logical model is shown in the figure below.

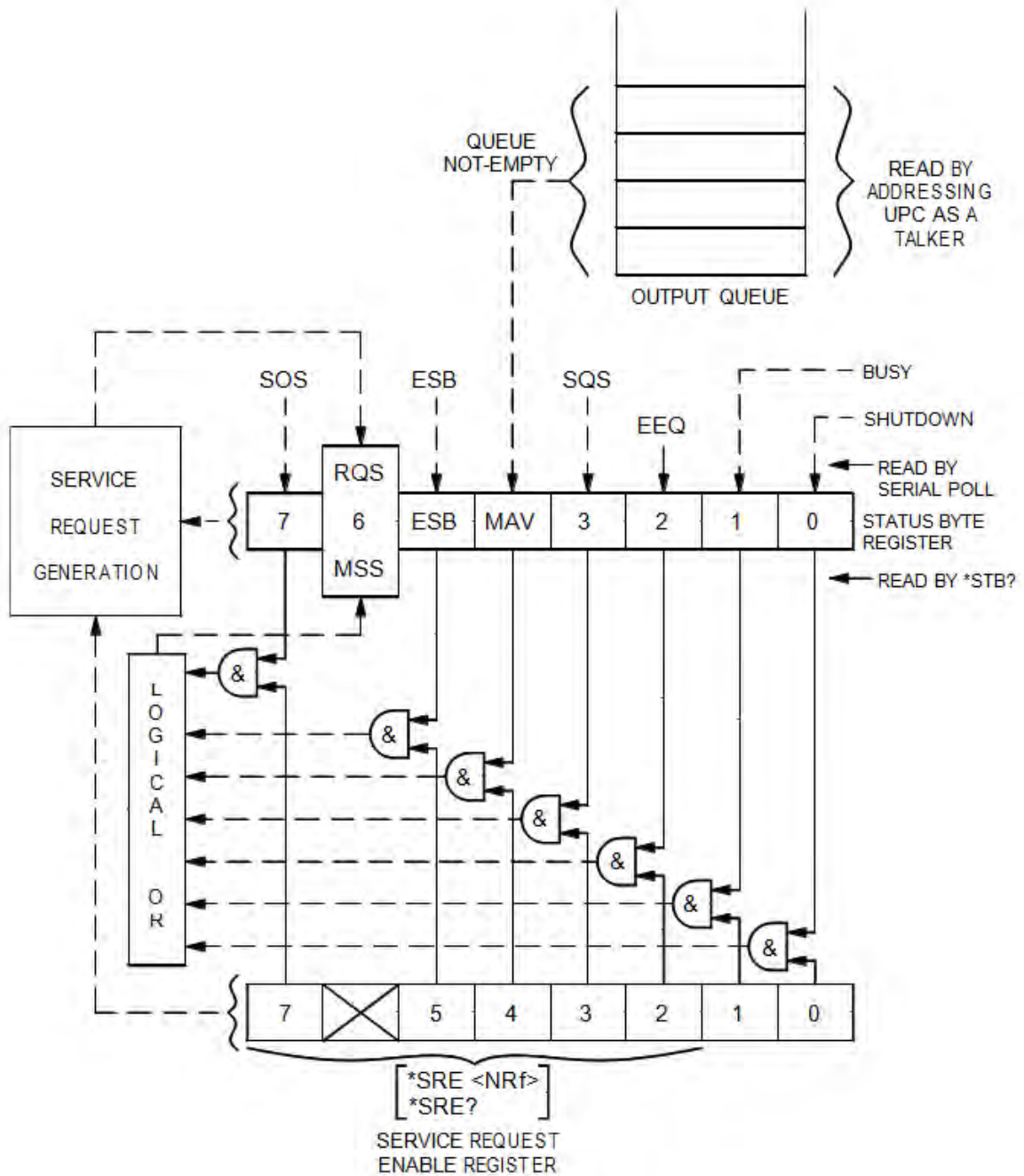

Figure 8-3: Status Byte Logical Model

8.14.2 Status Event Register (ESR)

Events reported by the STANDARD EVENT STATUS register may be queried via the *ESR? command. Reading the ESR register clears it. The EVENT STATUS summary bit in the STATUS BYTE (STB) will be set when an unmasked EVENT STATUS bit goes true.

BIT	NAME	DEFINITION
7	PON	POWER ON indicates Input power was just applied
6	URQ	USER REQUEST indicates "LOCAL" key was just pressed
5	CME	COMMAND ERROR indicates invalid command or query received
4	EXE	EXECUTION ERROR indicates can't execute command with data received
3	DDE	DEVICE DEPENDANT ERROR indicates UPC not properly configured
2	QYE	QUERY ERROR indicates cannot respond with data
1	RQC	REQUEST CONTROL - not used
0	OPC	OPERATION COMPLETE indicates previous operation complete

Table 8-5: Status Event Register (ESR)

Setting an EVENT STATUS ENABLE (ESE) bit true unmask the EVENT bit in the ESR. Also see :SYSTem:ERRor? query for relevant information.

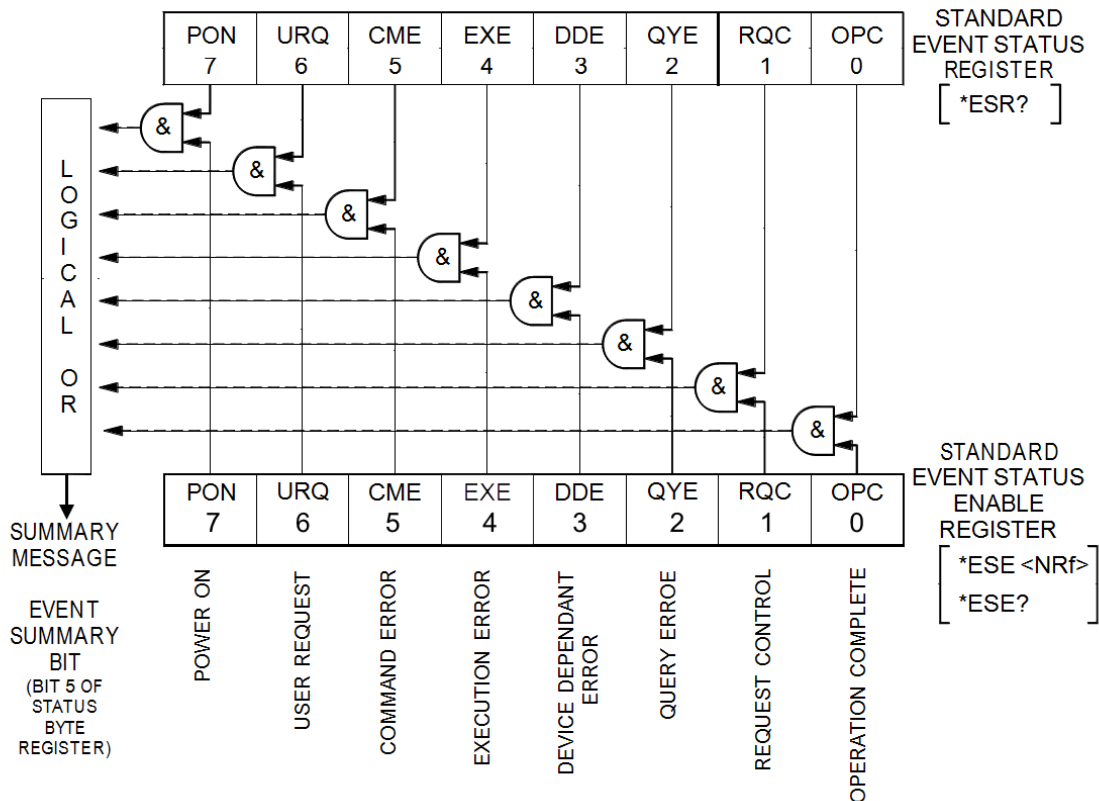

Figure 8-4: Standard Event Register (ESR) Model

8.14.3 SCPI Status Registers

The STATUS:OPERation and STATUS:QUESTIONable registers provide information about the present mode of operation.

- Transition of a CONDITION bit to the true state causes the EVENT bit to be set true.
- Unmasked ENABLE bits allow an EVENT bit to be reported in the summary bit for that EVENT register in the STATUS BYTE register.
- Setting an ENABLE bit true, unmask the corresponding EVENT bit.
- Reading an EVENT register clears it.
- All :STATUS registers are 16 bits (Figure 5.3).

The STATUS:OPERation register provides information about the present mode of operation.

Relevant commands for the STATUS:OPERation register are:

:STATUS:OPERation:CONDition?

:STATUS:OPERation:ENABle

:STATUS:OPERation:ENABle?

:STATUS:OPERation:EVENT?

The STATUS:QUESTIONABLE register provides information about errors and questionable measurements.

Relevant commands for the STATUS:QUESTIONABLE register are:

:STATUS:QUESTIONable:CONDition?

:STATUS:QUESTIONable:ENABle

:STATUS:QUESTIONable:ENABle?

:STATUS:QUESTIONable:EVENT?

Refer to Figure 8-5, “SCPI Status Registers Model” for details on registers.

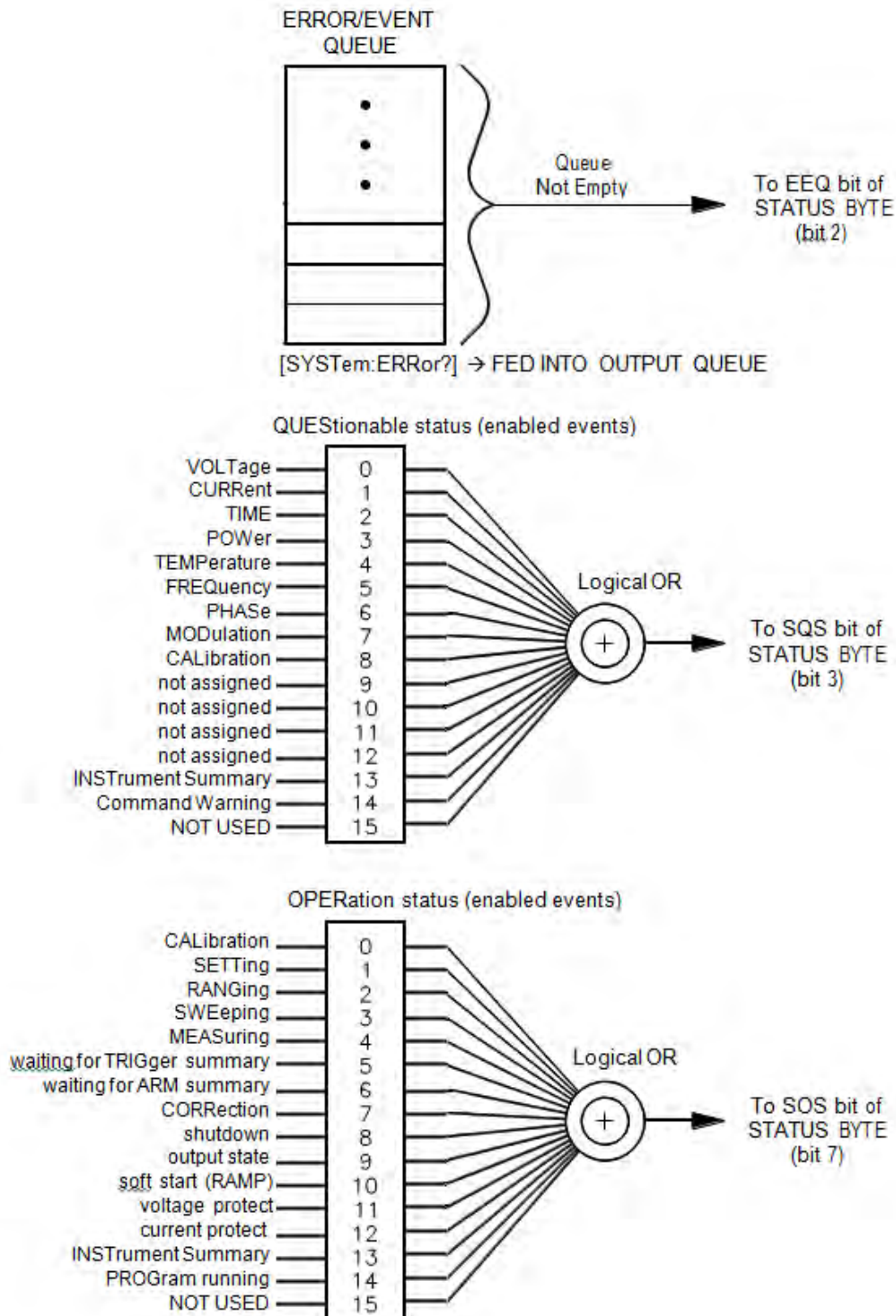

Figure 8-5: SCPI Status Registers Model

9 USB Driver Installation

9.1 Overview

The USB interface provides a virtual COM port for the PC. Via this port, the unit can be controlled as a normal RS232 interface, e. g. with a terminal program or user application program. There are two drivers provided with the AFX units:

- Virtual COM driver** This allows communication with the power sources using a virtual serial port (COMx).
- Network Driver** This allows communication with the power source using a virtual IP address. Using this driver, all built-in web server functions are available via USB using a browser.

9.2 Installation

USB drivers are stored in the AFX controller and installed when the unit is first connected to a Windows PC. Proceed as follows:

1. With the AFX unit powered up, connect a USB cable between the AFX USB Device port on the rear panel and an available USB port on a Windows PC.
2. Once plugged it, the PC should detect the present of the AFX. If this is the first time you connect to this PC, the drivers must be installed. This process should run automatically but if for some reason it does not, follow the subsequent steps.
3. On the drive popup shown below, select the “Open folder to view files” entry.

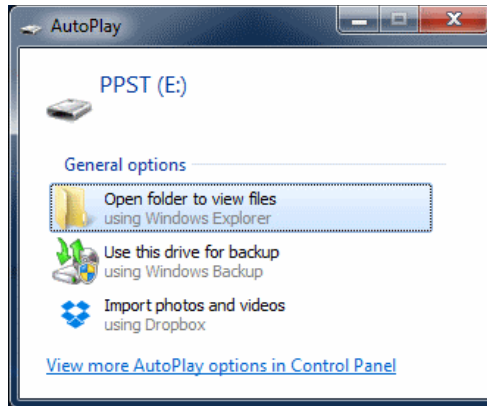

4. The directories shown below will be visible. Select the “drivers” directory

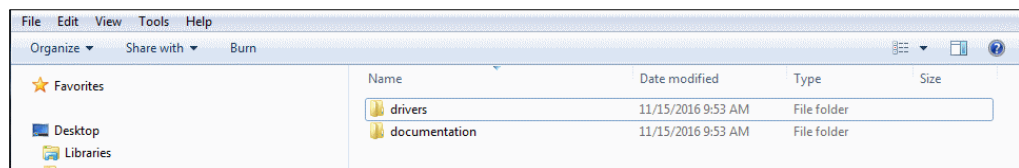

- Next, select the “Windows” directory

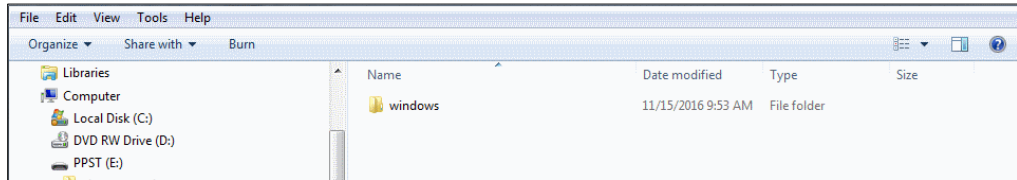

- Run the “Driver_Installer.exe” located in this directory as shown below.,

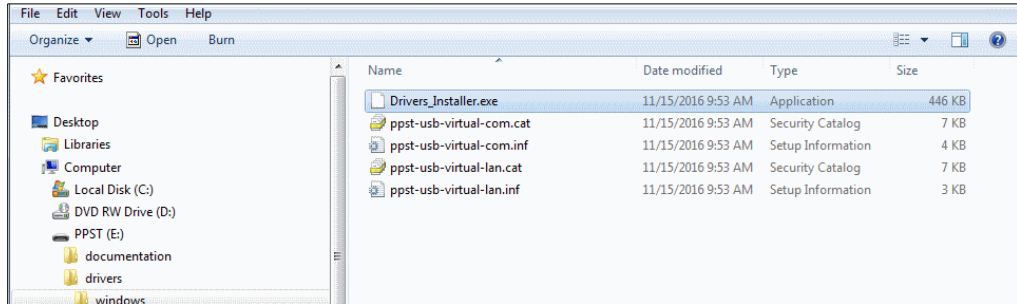

- Allow the installation to complete.

At the end of this process, you should be able to see the two PPST USB drivers in the Windows Device Manager window under “Network Adaptors” and “Ports (COM & LPT)” respectively. The USB interface is now ready for use.

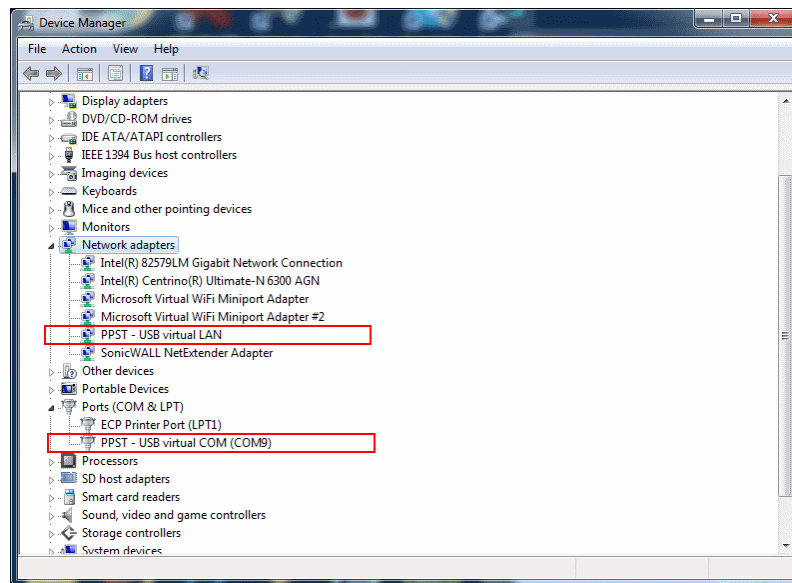

Figure 9-1: PPST USB Drivers visible in Windows Device Manager

10 LAN Interface Configuration

10.1 Overview

All AFX models are equipped with a LAN (Ethernet) interface. As shipped, the unit automatically obtains an IP address from the network using the DHCP protocol. If the instrument is turned off for long periods, the IP address lease may expire and a new IP address will be assigned. If this is the case, it is possible to assign a fixed IP address instead.

10.2 Web Browser Interface

The AFX Series® conforms to the LXI (Lan eXtensions for Instrumentation) standard and as such as a built in web server. This allows communication with the AFX from any web browser as long as the AFX is on the same network.

Note: The AFX web server has been tested with Google Chrome and Mozilla Firefox browsers only. Microsoft Internet Explorer is now obsolete and is not supported. Other browser like Edge or Safari may not fully operate or display information correctly.

Note: Web server use from a browser is **not** supported in *UPC Compatibility* mode. Disable this mode when operating the AFX from a web browser.

Use the IP address shown in the LAN INTERFACE SETUP screen under the SYSTEM key to determine the IP address to type into the web browser.

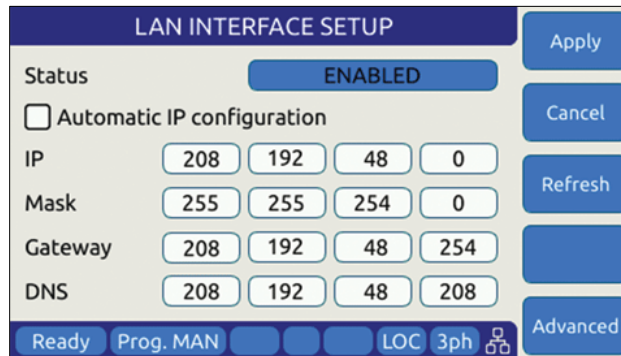

LAN INTERFACE SETUP				
Status	ENABLED			
<input type="checkbox"/> Automatic IP configuration				
IP	208	192	48	0
Mask	255	255	254	0
Gateway	208	192	48	254
DNS	208	192	48	208
Ready Prog. MAN LOC 3ph				



CAUTION: BEFORE USING BROWSER CONTROL

Verify that the level of remote access control is appropriate for the situation at hand. The power source is capable of producing lethal output voltage and operating it without being physically in the same room or space present a safety risks to others. Refer to 10.3.2, “**Front Panel Access Control**”.

If the unit is on the same network or reachable through the internet, the home screen of the AFX web server will appear.

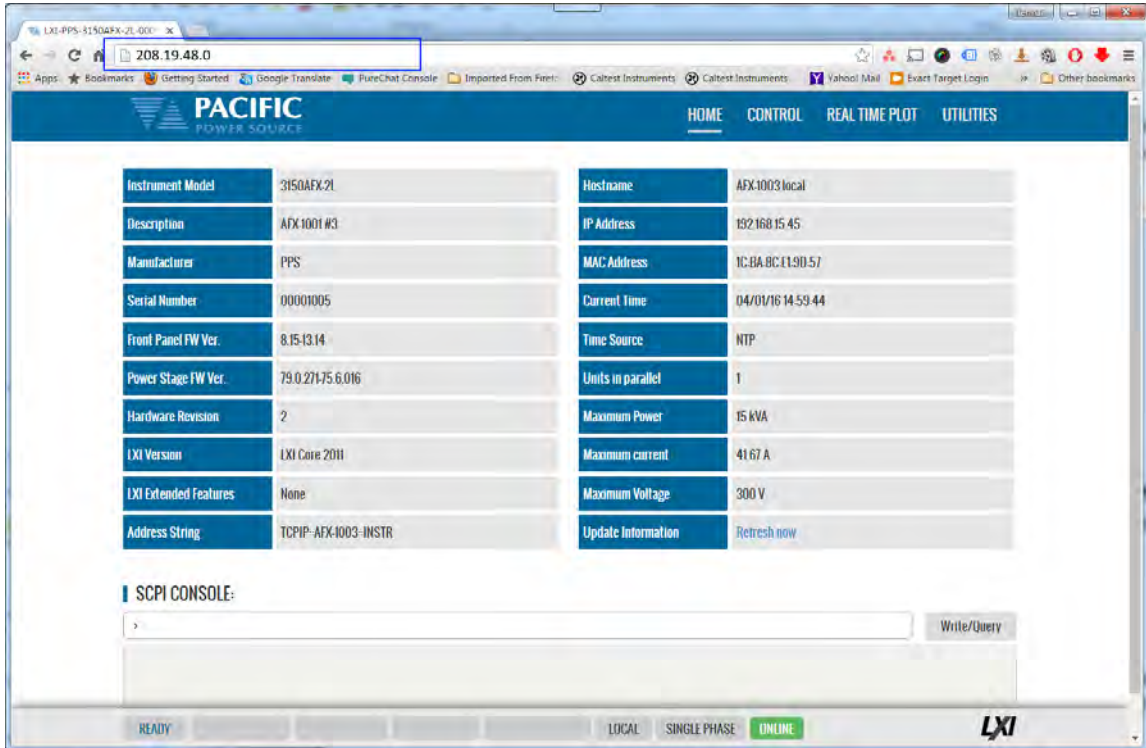

Figure 10-1: LXI Web Server Home Screen

When permitted, the browser interface allows monitoring of measurements and/or full control of the power source. If the operator is not near the actual instruments being controlled, care must be taken to the appropriate access control limits.

10.3 Access Control

Since the power source is capable of producing hazardous voltages at its output terminals, remote operation of the product over a LAN connection or any other available remote control interface can be restricted by the user to include only monitoring functions rather than full programming controls.

This feature is provided to ensure the safety of anyone near the unit in its actual physical location. This access control mechanism requires granting specific access to certain functions and features from the front panel by a person present at the location of the power source and requesting permission first trying to access a unit remotely.

These access control functions can be set from the SYSTEM Menu, INTERFACE screen or via the webserver using any browser.



CAUTION

All AFX Units are shipped from the factory with ACCESS CONTROL **DISABLED. It is the instrument's owner's responsibility to enable these features.**

10.3.1 Browser Access Control

When connecting to the power source via a browser on which access has been restricted, the following message will appear:

The browser Access dialog is shown below.

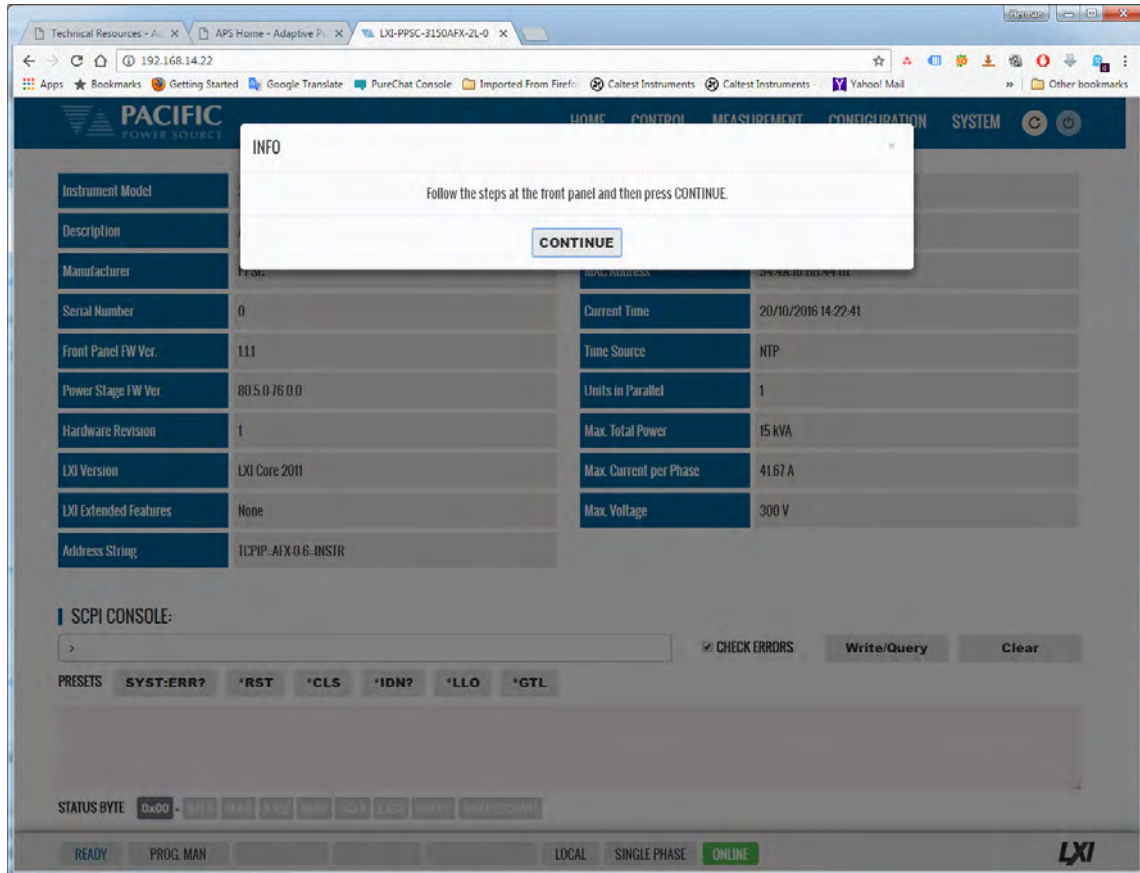

Figure 10-2: ACCESS CONTROL Dialog Screen

If the operator knows the four-digit access password that was set on the actual unit, he can enter the password code and gain full control of the source or Monitor⁹ only access depending on which mode was selected.

If the operator does not know the password, he can request access. Such a request can only be granted by a person who is in front of the actual unit however. This prevents unauthorized access from a remote location and protects the local user from possible harm. An Access Request will result in a Pop-Up message on the power source LCD screen.

The access control password can be set/changed only by the person(s) present at the physical location of the unit. Factory default password is “1234” but it is strongly **advised** the end user changes this to his own code after receipt of the unit.

If access is denied, the browser interface will enter MONITOR only mode in which measurements and settings can be viewed remotely but control is possible. When in this mode, a user with knowledge of the access password can enter FULL CONTROL mode by supplying the

⁹ Note: Monitor Only access mode requires firmware revision 3.6.44 or higher.

correct password or request full access from a local operator that is present at the unit’s location.

This dialog will appear when opening the browser interface while a unit is under ACCESS CONTROL.

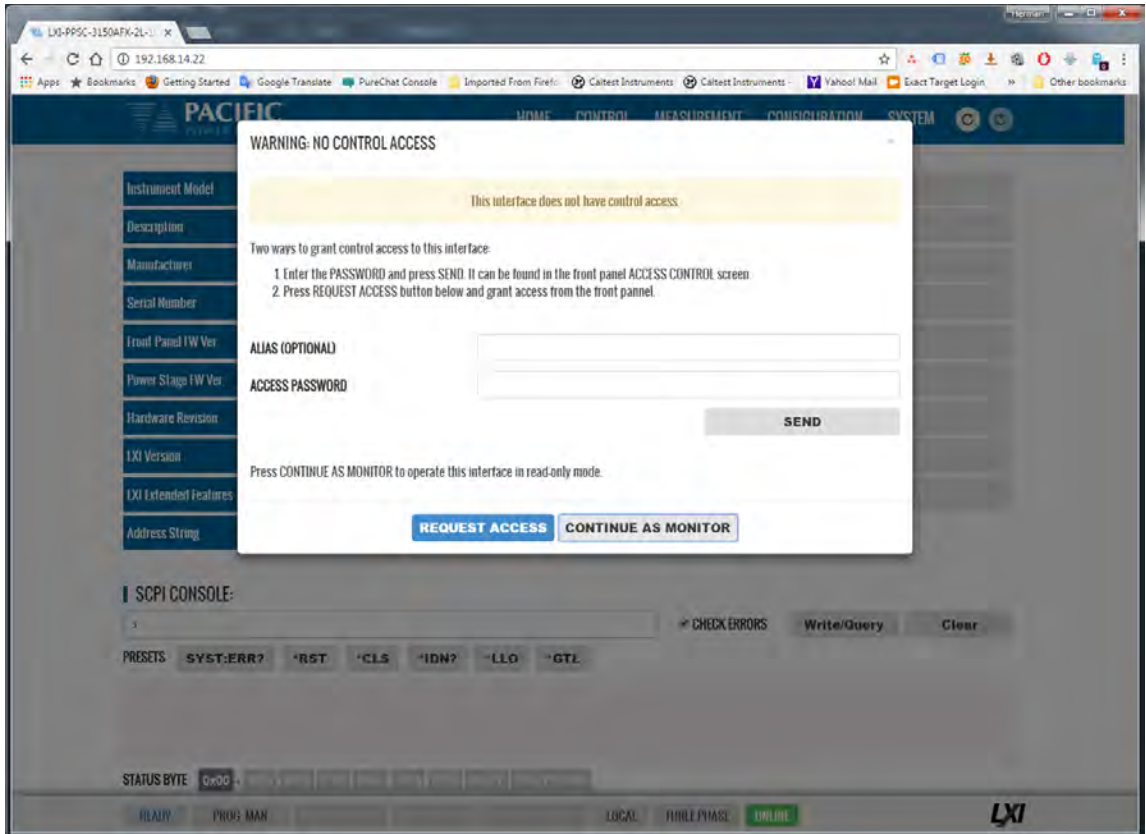

Clicking on “REQUEST ACCESS” will result in a dialog box appearing on the unit’s LCD screen displaying the requestor’s IP address. A message on the browser will indicate action is needed by the local operator. Now, the local operator can either DENY or GRANT access.

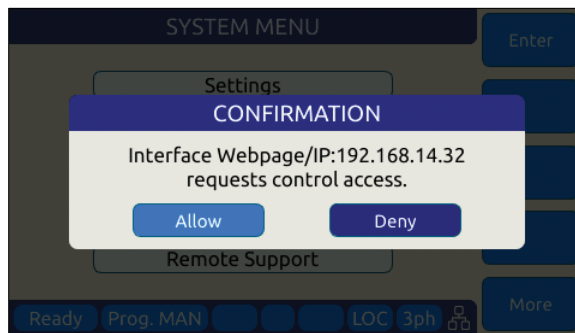
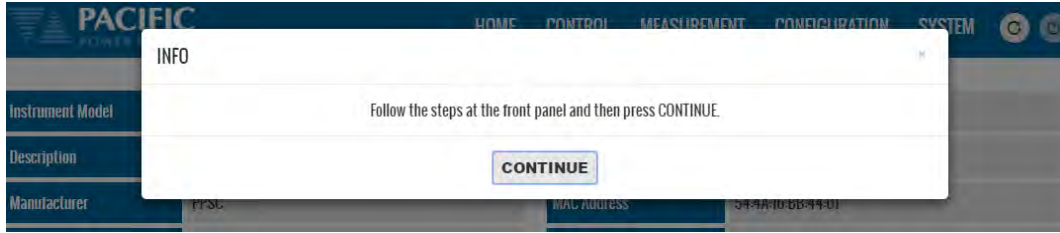

Figure 10-3: Remote Access Control Request Dialog

If remote access is granted, full control is provided. If denied, only monitoring is available.

Note: If the remote operator was given the ACCESS passcode, he can use it to gain access without a local operator’s intervention.



When granted, the requestor’s IP address will be added to the whitelist IP. The operator can remove any of the white listed IP address at any time if needed. This will lock out remote access for that PC until access is re-granted anew.

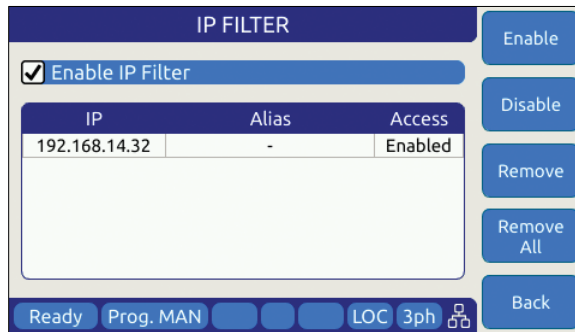
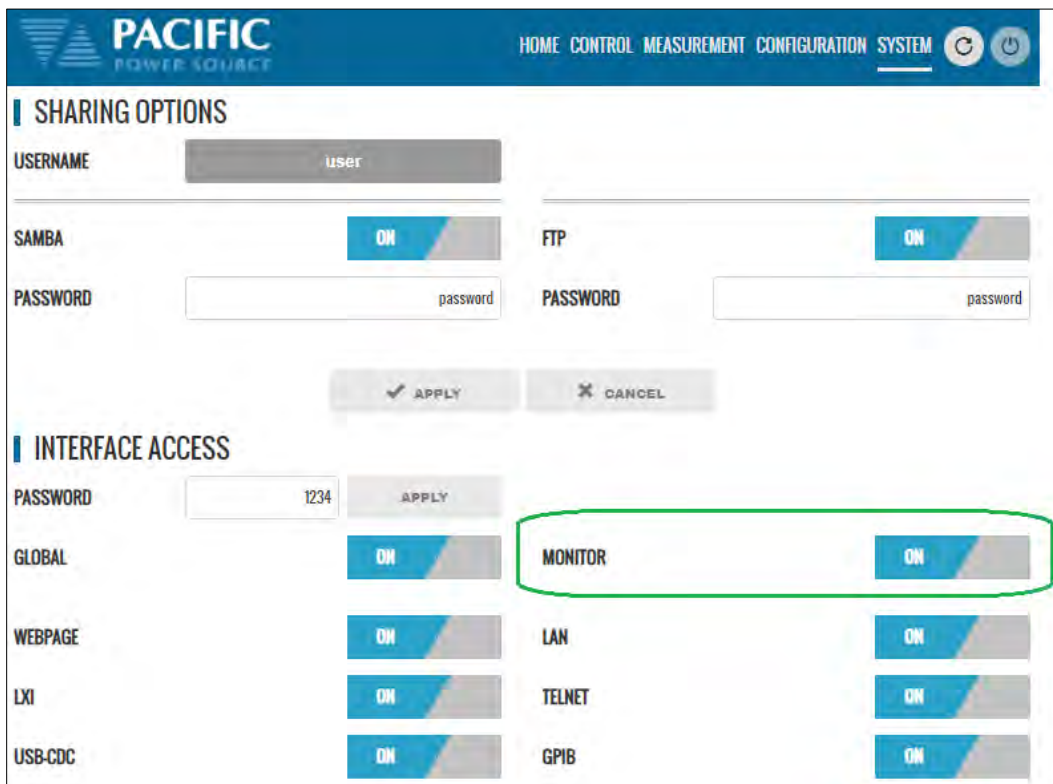
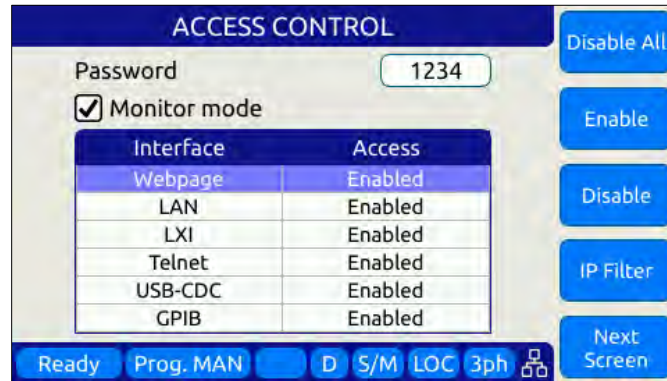

Figure 10-4: Remote Access Control IP Filter screen

Remote access can be configured from the System menu. To enable Monitor only mode, turn MONITOR on as shown below. In this mode, settings and measurements can be viewed but no changes can be made remotely.



Monitor mode can also be selected from the front panel using the System, Access Control screen as shown below.



If Monitor mode is disabled, the browser access control screen will look like this.

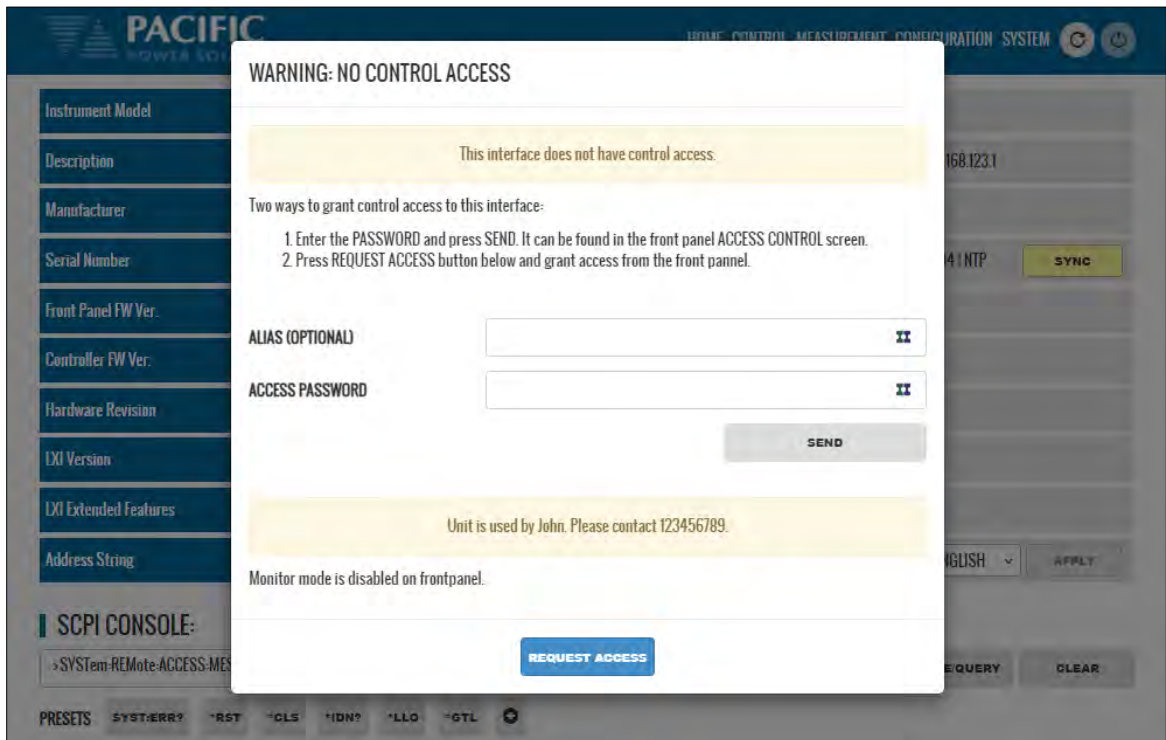

The message at the bottom of the screen can be set by the main user with the `SYSTEM:REMOte:ACCESS:MESSAge` SCPI command. In this example, the following command was used:
`SYSTEM:REMOte:ACCESS:MESSAge "Unit is used by John. Please contact 123456789."`

10.3.2 Front Panel Access Control

Setting remote control access levels and interface types is accomplished from the SYSTEM menu under Interfaces.

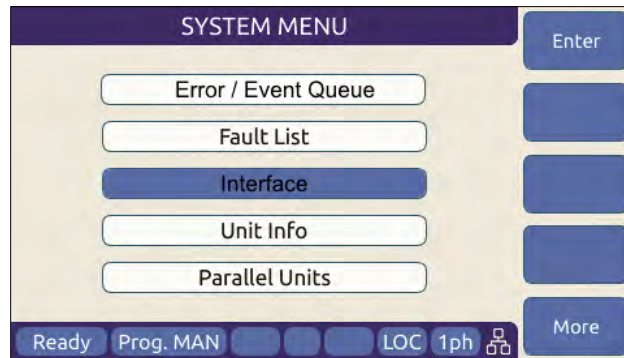

Scroll down to the INTERFACE entry and press Enter to access the available INTERFACE SETUP screen.

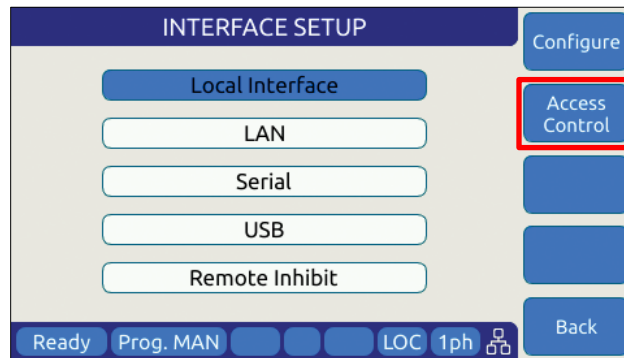

The second soft key is labelled “Access Control” and brings up the access control screen shown below.

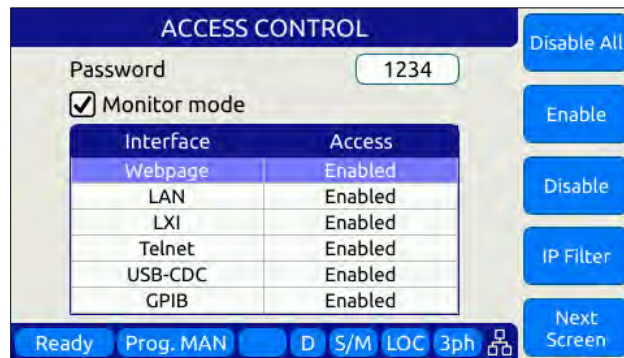

The IP Filter list will provide access to the list of IP addresses that have been granted access by the local operator. This list can be erased if it is necessary to deny future access to the power source.

10.4 Web Browser Interface

The AFX Series® conforms to the LXI (Lan eXtensions for Instrumentation) standard and features a built-in web server with a greatly expanded feature set. This allows communication with the AFX from any web browser as long as the AFX is reachable through the network or internet. The expanded feature set of the web server often eliminates the need to use additional Windows or other platform based software.

10.5 Available Web Interface Menu Tree

The following areas of control, monitoring and configuration of the AFX power source are available through a web browser.

- Home Screen – Required for LXI compliance
- Home Screen SCPI Console Command Line Interface
- SOURCE CONTROL
 - PROGRAM
 - PROTECTIONS
 - TRANSIENTS
 - PROGRAM MEMORY
 - WAVEFORM
 - WAVEFORM EDITOR
 - SCPI SCRIPT
- MEASUREMENTS
 - MONITOR
 - REAL-TIME PLOT
 - V/I PLOT
 - DATALOGGER
 - SCOPE
 - HARMONICS
- CONFIGURATION
 - UNIT SETTINGS
 - USER LIMITS & PRESETS
 - RAMP & SLEW
- SYSTEM
 - ERROR/EVENT QUEUE
 - FAULT LIST
 - INTERFACE SETUP
 - ACCESS CONTROL
 - DIGITAL & ANALOG IOS
 - UNIT INFORMATION
 - PARALLEL UNITS
 - MEMORY MANAGER
 - CALIBRATION
 - REMOTE SUPPORT
 - IMPORT/EXPORT
 - FIRMWARE UPDATE
 - SANITIZE & REBOOT

Following sections provide an overview of each page of the web browser interface.

10.6 Home Screen

The Home screen contains all required information relating to the instrument and its LAN connection as required by the LXI standard. This includes hardware and firmware revision information. The NTP clock **SYNC** button in the Current Time field is yellow if it detects that the date, time or zone is different than the computer, otherwise is in gray. Press the button to sync to the NTP time server.

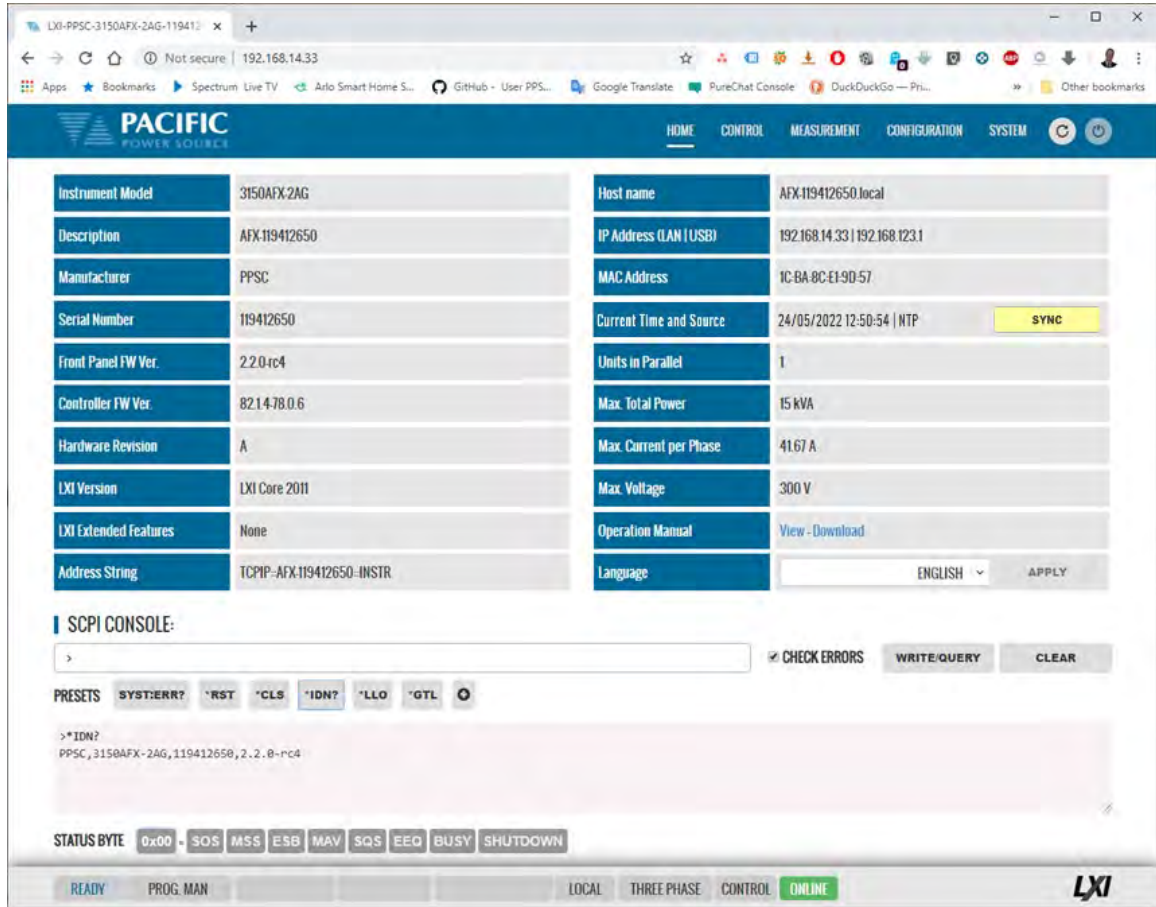

10.6.1 SCPI Console Command Line Interface

Near the bottom of the screen is an interactive command line interface that allows individual SCPI commands to be sent to the instrument. Any query results are shown in the text box below the command line. A drop-down list of all available commands is integrated in the command line and as you type a command, a match will be tracking in the drop down list allowing you to select the complete command without typing it out. See sample below after typing "SY".

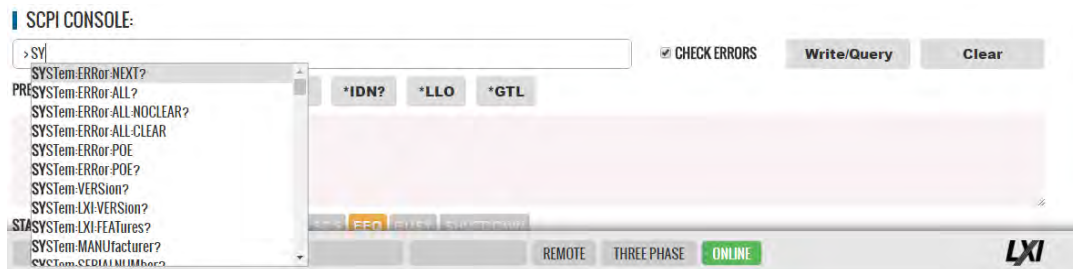

Note: AFX models with firmware revision 2.1.0 or higher also support a SCPI Command scripting function. See Section 10.7.7, “SCPI Script” on page 454.

10.6.2 Status Byte Display

At the very bottom of the Home Screen, the status byte register value and decoded fields are displayed for reference. Status byte fields are described in section 0, “

Status Byte Register (STB)” on page 421.

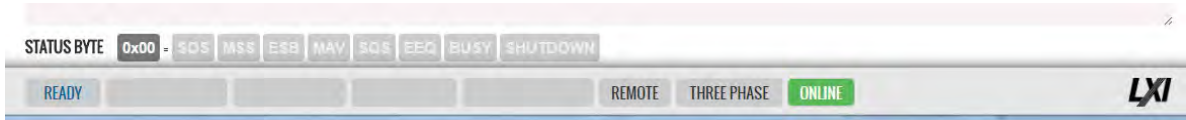

10.6.3 Browser Status Bar

The browser status bar shows configuration information about the instrument. This includes any error or event flags, remote or local status, phase mode selection and on or off line status.



The first field will display **READY** while the power source output is OFF and **ENABLED** when it is ON (enabled).

10.6.4 Operation Manual PDF

The AFX Operation Manual is stored on the AFX’s internal memory and available for download to the user’s PC (“Download”) or for viewing using a suitable browser of PDF viewer (“View”).

PACIFIC POWER SOURCE		HOME CONTROL MEASUREMENT CONFIGURATION SYSTEM	
Instrument Model	3150AFX-4L-M16022	Hostname	AFX-105624006.local
Description	AFX-105624006	IP Address	192.168.26.29
Manufacturer	PPSC	MAC Address	54:4A:16:BB:40:09
Serial Number	105624006	Current Time	30/01/2017 15:16:13
Front Panel FW Ver.	1.3.5	Time Source	NTP
Power Stage FW Ver.	80.7.0-76.0.0	Units in Parallel	1
Hardware Revision	0	Max. Total Power	15 kVA
LXI Version	LXI Core 2011	Max. Current per Phase	41.67 A
LXI Extended Features	None	Max. Voltage	300 V
Address String	TCPIP::AFX-105624006::INSTR	Operation Manual	View - Download

10.7 Source Control Screens

The CONTROL menu provides access to several screens that allow programming of the power source. Control Menu entries are as follows:

- PROGRAM
- PROTECTIONS
- TRANSIENT
- PROGRAM MEMORY
- WAVEFORM
- WAVEFORM EDITOR
- SCPI SCRIPT
- TEST SEQUENCE

Each is described in subsequent sections.

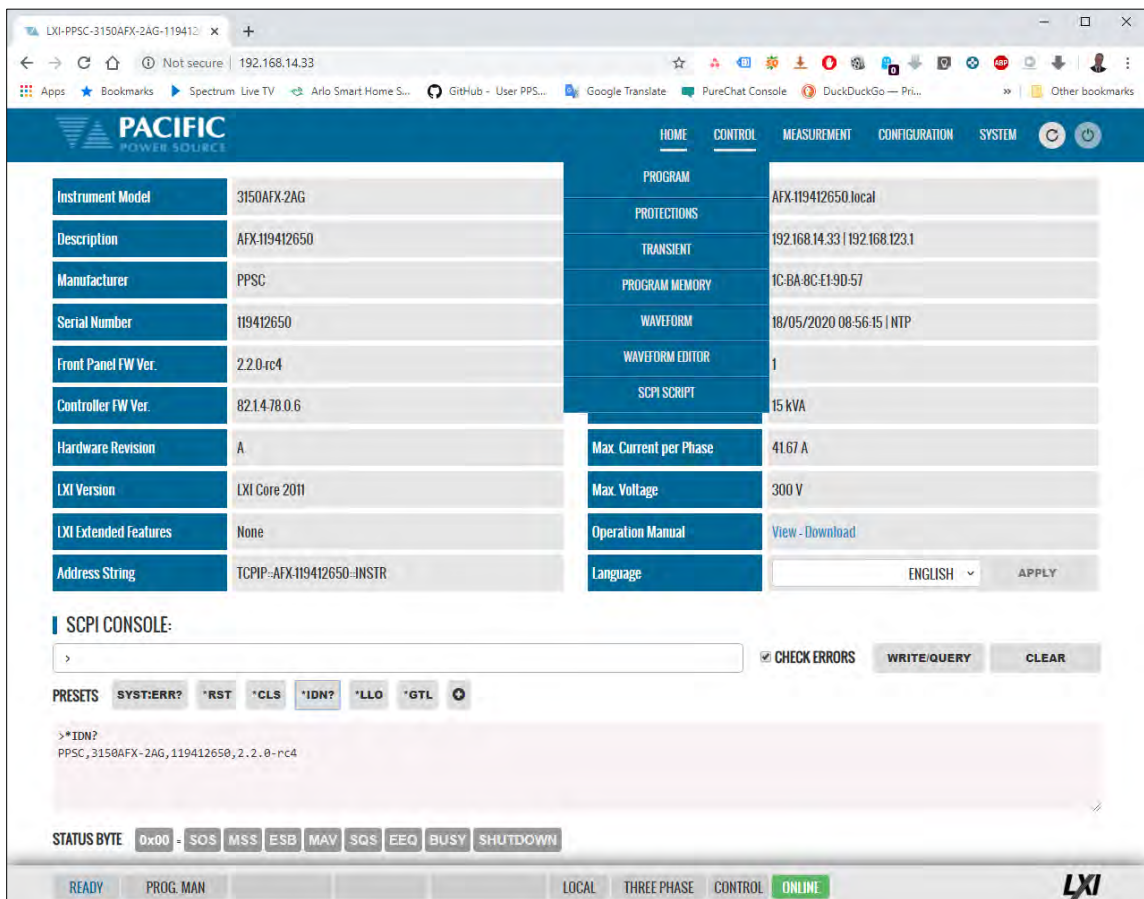

The screenshot displays the Pacific Power Source web interface. The top navigation bar includes HOME, CONTROL, MEASUREMENT, CONFIGURATION, and SYSTEM. The main content area is divided into two columns. The left column lists instrument details:

Instrument Model	3150AFX-2AG
Description	AFX-119412650
Manufacturer	PPSC
Serial Number	119412650
Front Panel FW Ver.	2.2.0.rc4
Controller FW Ver.	82.14-78.0.6
Hardware Revision	A
LXI Version	LXI Core 2011
LXI Extended Features	None
Address String	TCPIP-AFX-119412650-INSTR

The right column shows the CONTROL menu options and their values:

PROGRAM	AFX-119412650.local
PROTECTIONS	192.168.14.33 192.168.123.1
TRANSIENT	1C-BA-8C-E1-90-57
PROGRAM MEMORY	18/05/2020 08:56:15 NTP
WAVEFORM	1
WAVEFORM EDITOR	15 kVA
SCPI SCRIPT	41.67 A
Max. Current per Phase	300 V
Max. Voltage	View - Download
Operation Manual	ENGLISH
Language	APPLY

Below the menu is the SCPI CONSOLE section, which includes a text input field, a "CHECK ERRORS" checkbox, and buttons for "WRITE/QUERY" and "CLEAR". The console shows the following output:

```
>*IDN?
PPSC,3150AFX-2AG,119412650,2.2.0-rc4
```

At the bottom, there is a STATUS BYTE section with buttons for 0x00, SOS, MSS, ESB, MAV, SQS, EEQ, BUSY, and SHUTDOWN. The bottom status bar shows: READY | PROG. MAN | LOCAL | THREE PHASE | CONTROL | ONLINE | LXI

10.7.1 Program

The program control screen allows programming of all output parameters, operating modes etc. It also displays measurement data for all available phases in the lower part of the screen. In three or two phase mode, Line-to-Line voltage measurements are displayed at the bottom of the screen. The Output can be enabled using the “OUTPUT ENABLE” controls in the upper PROGRAM screen. The Output can also be turned **OFF** from any screen using the RED On/Off symbol in the menu bar, which is accessible from all screens. This allows quick opening of the output relay if needed from any screen without have to first select the PROGRAM screen. Note that the output can only be turned **ON** (or OFF) from the PROGRAM screen however.

The screenshot shows the 'PROGRAM' screen with the following controls and data:

PROGRAM CONTROLS:

- OUTPUT ENABLE:** ON (selected) / OFF
- FREQUENCY:** 50.00 Hz
- VOLTAGE AC:** 100.00 V_{RMS}
- VOLTAGE DC:** 0.00 V_{DC}
- SELECTED PHASE:** ABC (selected), A (highlighted with a red box and arrow), B, C
- CURRENT LIMIT:** 4.167 A_{RMS}
- POWER LIMIT:** 5.0000 kW
- KVA LIMIT:** 5.0000 kVA
- Buttons: APPLY, CANCEL

MEASUREMENTS:

	Phase A	Phase B	Phase C
FREQUENCY	50.00 Hz	50.00 Hz	50.00 Hz
VOLTAGE L-N RMS (AC-DC)	100.00 V _{RMS}	100.00 V _{RMS}	100.00 V _{RMS}
VOLTAGE L-N RMS (AC)	100.00 V _{RMS}	100.00 V _{RMS}	100.00 V _{RMS}
VOLTAGE L-N DC	0.00 V _{DC}	0.00 V _{DC}	0.00 V _{DC}
CURRENT RMS (AC-DC)	4.96 A _{RMS}	5.12 A _{RMS}	5.10 A _{RMS}
CURRENT DC	0.22 A _{DC}	0.21 A _{DC}	0.10 A _{DC}
POWER	0.495 kW	0.512 kW	0.509 kW
WATT-HOUR RESET	0.002 kWh	0.002 kWh	0.002 kWh
APP POWER	0.496 kVA	0.512 kVA	0.510 kVA
POWER FACTOR	1.00	1.00	1.00
CURRENT CF	1.47	1.46	1.44
PEAK CURRENT	7.27 A	7.49 A	7.34 A
RECORDED PEAK CURRENT RESET	7.44 A	8.94 A	8.78 A

STATUS BAR: ENABLED, PRG. MAN, ERROR & EVENT, VOLTAGE MODE, REMOTE, THREE PHASE, CONTROL, ONLINE, LXI

10.7.2 Protections

The Protections screen may be used to change protection modes and threshold values. This includes RMS current, Peak Current, True Power and Apparent Power protection modes. Modes can be toggled on or off individually.

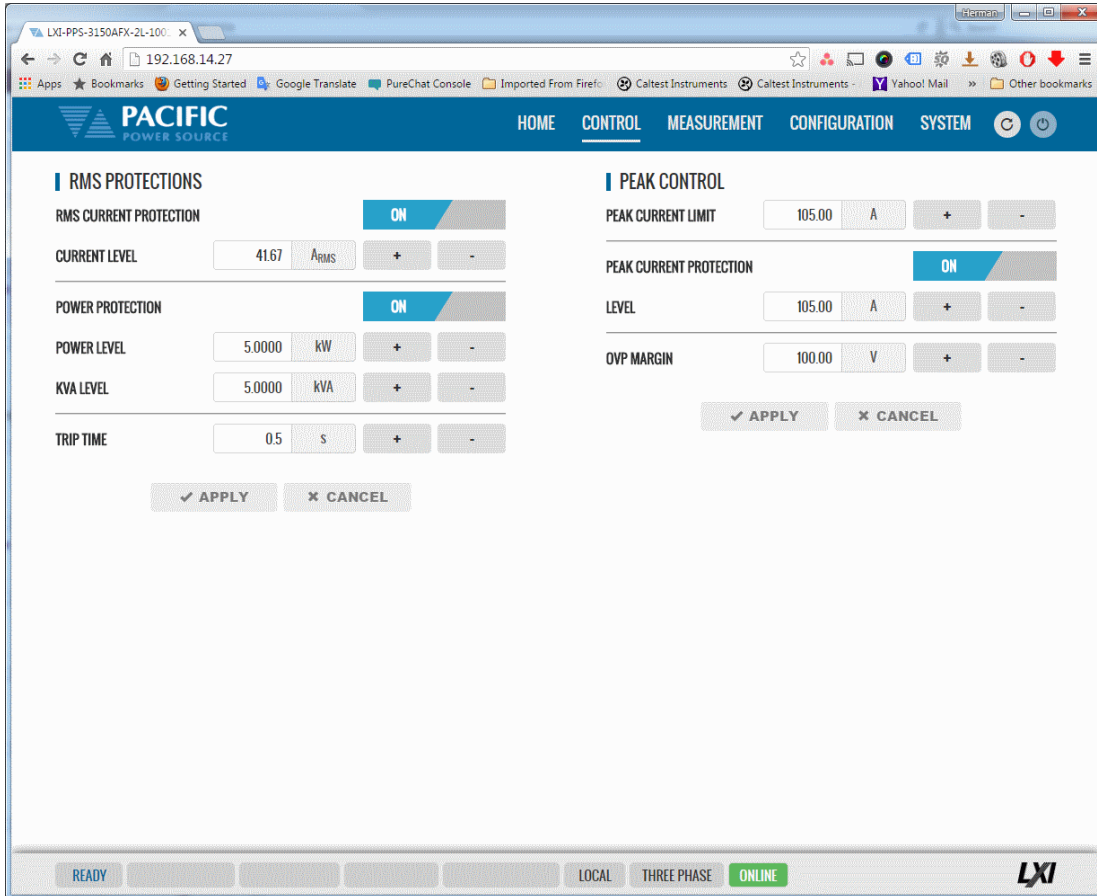

10.7.3 Transients

The transient control screen allows programming of new transients or execution control of new or stored transient programs. The power source supports LIST, STEP and PULSE transient modes.

The screenshot shows the LXI web interface for a Pacific Power Source. The main content area is divided into two columns. The left column contains a list of instrument details:

Instrument Model	3150AFX-2AG
Description	AFX:119412650
Manufacturer	PPSC
Serial Number	119412650
Front Panel FW Ver.	2.2.0.rc4
Controller FW Ver.	82.14.78.0.6
Hardware Revision	A
LXI Version	LXI Core 2011
LXI Extended Features	None
Address String	TCPIP-AFX:119412650-INSTR

The right column contains configuration options for the transient control screen:

PROGRAM	AFX:119412650.local
PROTECTIONS	
TRANSIENT	PROGRAM
PROGRAM MEMORY	STEP
WAVEFORM	PULSE
WAVEFORM EDITOR	1
SCPI SCRIPT	15 kVA
Max. Current per Phase	4167 A
Max. Voltage	300 V
Operation Manual	View - Download
Language	ENGLISH <input type="button" value="APPLY"/>

Below the configuration options is the SCPI console, which shows the following text:

```

>*IDN?
PPSC, 3150AFX-2AG, 119412650, 2.2.0.rc4
  
```

The console also includes a status bar at the bottom with the following indicators: READY, PROG. MAN, LOCAL, THREE PHASE, CONTROL, and ONLINE.

10.7.3.1 LIST Transients

For LIST transients, both STEP mode and SEGMENT mode is supported. The bottom part of the screen shows the editable transient table. Execution controls are located in the top part of the screen.

Data entry mode can be selected as either STEP or SEGMENT. Dwell times can be entered using msec (TIME BASED) or cycles (CYCLE BASED). A sample TIME BASED Segment mode list is shown below.

The screenshot shows the 'TRANSIENT EXECUTION' and 'TRANSIENT TABLE' sections of the Pacific Power Source web interface. The 'TRANSIENT EXECUTION' section includes controls for RUN, STOP, STEP, and RESTART, along with fields for RUN FROM SEGMENT # (1), RUN TO SEGMENT # (4), and REPEAT TIMES (Infinite). The 'TRANSIENT TABLE' section shows a table with columns for #, TIME [ms], FREQ [Hz], V_{AC} [V_{RMS}] A/B/C, V_{DC} [V] A/B/C, Waveform [#] A/B/C, and Phase [deg] B/C. The 'SEGMENT' mode and 'TIME BASED' edit mode are highlighted with red boxes.

#	TIME [ms]	FREQ [Hz]	V _{AC} [V _{RMS}] A/B/C	V _{DC} [V] A/B/C	Waveform [#] A/B/C	Phase [deg] B/C		
> 1	1000.0	60.00	120.00	0.02	1	120.00/240.00	+	x
> 2	16.6	60.00	132.00/120.00/120.00	0.01	1	120.00/240.00	+	x
> 3	5000.0	60.00	120.00	0.00	1	120.00/240.00	+	x
> 4	100.0	60.00	120.00/132.00/108.00	0.00	1	120.00/240.00	+	x

Import / Export Function

List Transients can be saved to excel compatible CSV files using the EXPORT button at the bottom of the List transient screen. A sample is shown to the right.

These same files can be Imported later eliminate the need to re-enter the transient list. The IMPORT button opens a file browser so select and load previously save CSV transient files. This function automatically changes between step or segment mode and edit mode according to the CSV file content.

A sample CYCLE BASED Segment mode list is shown below.

```
transient.csv - Notepad
File Edit Format View Help
SEP=,
Mode=Segment
Edit Mode=Time based
Time[ms],Frequency [Hz],AC [RMS],DC,Phase [Deg], Waveform
10.0,60,5/6/7,30/20/10,0/120/240,1/1/1
200.0,65,5/6/7,30/20/10,0/120/240,1/1/1
200.0,75,0/0/0,0/0/0,0/120/240,2/2/2
```

The screenshot displays the Pacific Power Source web interface. The top navigation bar includes HOME, CONTROL, MEASUREMENT, CONFIGURATION, and SYSTEM. The main content area is divided into two sections:

- TRANSIENT EXECUTION:** This section contains controls for running and stopping a transient test. The state is currently "STOPPED". It includes fields for "RUN FROM SEGMENT #", "RUN TO SEGMENT #", and "REPEAT TIMES" (set to Infinite). Buttons for RUN, STOP, STEP, RESTART, APPLY, and CANCEL are present.
- TRANSIENT TABLE:** This section displays a table of transient configurations. The "SEGMENT" and "CYCLE BASED" buttons in the "EDIT MODE" section are highlighted with red boxes. The table has columns for #, CYCLES, FREQ [Hz], V_{AC} [Vrms] A/B/C, V_{DC} [V] A/B/C, Waveform [#] A/B/C, and Phase [deg] B/C.

#	CYCLES	FREQ [Hz]	V _{AC} [Vrms] A/B/C	V _{DC} [V] A/B/C	Waveform [#] A/B/C	Phase [deg] B/C
> 1	60	60.00	120.00	0.02	1/1/1	120.00/240.00
> 2	1	60.00	132.00/120.00/120.00	0.01	1/1/1	120.00/240.00
> 3	300	60.00	120.00	0.00	1/1/1	120.00/240.00
> 4	6	60.00	120.00/132.00/108.00	0.00	1/1/1	120.00/240.00

At the bottom of the interface, there are status indicators: READY, PROG MAN, REMOTE, THREE PHASE, CONTROL, and ONLINE (highlighted in green). The LXI logo is visible in the bottom right corner.

Continued on next page...

A sample TIME BASED STEP mode list is shown below. (Not to be confused with STEP Transient mode, see next section.)

The screenshot shows the Pacific Power Source web interface. The 'TRANSIENT EXECUTION' section includes controls for running, stopping, and restarting a transient, along with a progress indicator showing 0% completion. The 'TRANSIENT TABLE' section is active, showing a table of transient steps. The 'STEP' and 'TIME BASED' buttons are highlighted with red boxes. The table contains four steps with various parameters like RAMP, DWELL, FREQ, V_{AC}, V_{DC}, Waveform, and Phase.

#	RAMP [ms]	DWELL [ms]	FREQ [Hz]	V _{AC} [V _{RMS}] A/B/C	V _{DC} [V] A/B/C	Waveform [#] A/B/C	Phase [deg] B/C		
> 1	0.2	1000.0	60.00	120.00	0.02	1	120.00/240.00	+	×
> 2	0.2	16.8	60.00	132.00/120.00/120.00	0.01	1	120.00/240.00	+	×
> 3	100.0	5000.0	60.00	120.00	0.00	1	120.00/240.00	+	×
> 4	100.0	0.0	60.00	120.00/132.00/108.00	0.00	1	120.00/240.00	+	×

During transient execution, a progress indicator is visible showing percent completion.

10.7.3.2 STEP Transients

STEP transients allow a ramp or stairstep output profile to be programmed without creating LIST transients with multiple entries. In STEP transient mode, the user enters initial value, end value, delta step size, step duration, step count and no of repeats.

The STEP EXAMPLE shows the relationship between the various parameters.

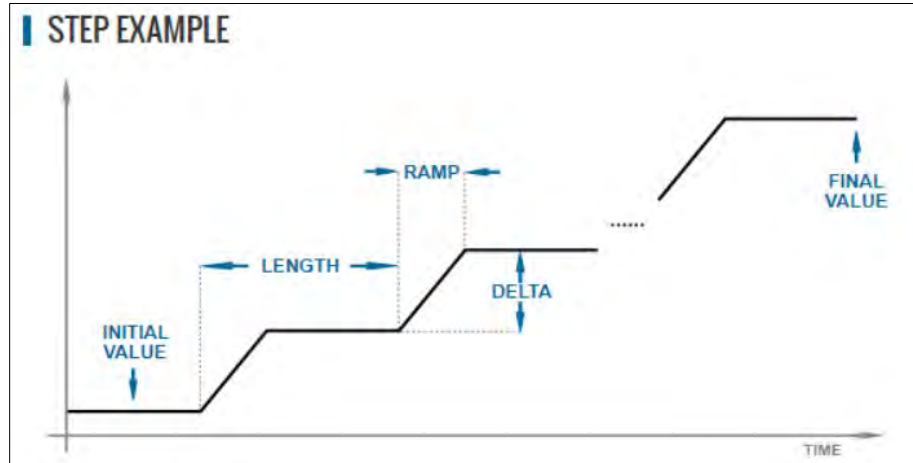

This information is transformed to a standard Segment based transient list by the power source when the LOAD button is pressed.

The screenshot shows the "STEP EXECUTION" control interface. At the top, there are navigation tabs: HOME, CONTROL, MEASUREMENT, CONFIGURATION, and SYSTEM. The "STEP EXECUTION" section includes buttons for RUN, STOP, STEP, and RESTART. The current state is "STOPPED". A "LOAD" button is highlighted with a red box. Below this, there are "STEP SETTINGS" for: STEP LENGTH (100.0 ms), STEP RAMP TIME (0.2 ms), STEP COUNT (10), REPEAT TIMES (1), PROGRAM MODE (INITIAL & DELTA VALUES), INITIAL VALUE STEP (ON), and HOLD FINAL VALUES (ON). To the right, the "STEP VALUES" table is shown:

SELECTED PHASE	SETPOINT	INITIAL	DELTA	FINAL	UNIT
ABC	60.00	60.00	0.00	60.00	Hz
A	0.00	0.00	0.00	0.00	V _{rms}
B	0.00	0.00	0.00	0.00	V _{dc}
C	0.00	0.00	0.00	0.00	V _{dc}

Below the table is a "STEP WAVEFORM" section with a dropdown set to "1" and a "VIEW CATALOG" button. At the bottom of the interface, there is a status bar with "READY", "PROG. MAN", "LOCAL", "THREE PHASE", "CONTROL", and "ONLINE" indicators, along with the LXI logo.

During transient execution, a progress indicator is visible showing percent completion.

10.7.3.3 PULSE Transients

PULSE transients allow series of pulsed output levels to be programmed without creating LIST transients with repetitive entries. In PULSE transient mode, the user enters Level, duty cycle, ramp time, period, initial value and pulse count. This mode is useful for high and low line testing for voltage and frequency operating limits of an EUT.

The PULSE EXAMPLE shows the relationship between the various parameters.

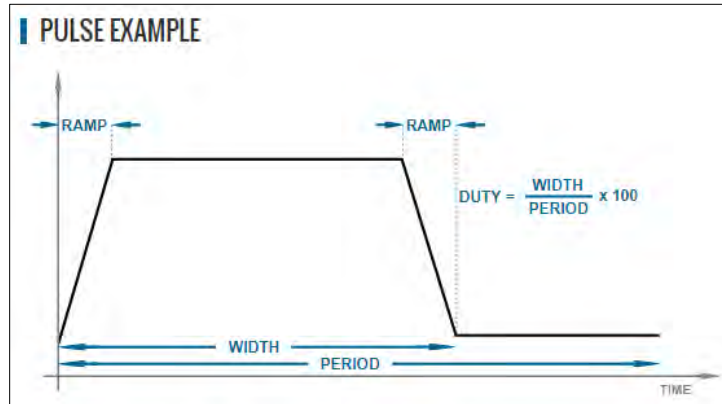

This information is transformed to a standard Segment based transient list by the power source when the LOAD button is pressed.

During transient execution, a progress indicator is visible showing percent completion.

10.7.4 Interharmonic

The Interharmonic screen allows the user to program one interharmonic¹ and up to 5 harmonic frequencies.

The interharmonics frequency and amplitude can be set in the upper part of the screen. The frequency set is independent of the programmed fundamental frequency. Amplitude can be set in absolute voltage. The controller uses a precision regulation loop for each of these five harmonics so harmonics amplitude is precisely regulated to compensate for load current and attenuation in the power source amplifiers. This results in a more precise amplitude accuracy for harmonics compared to using an arbitrary waveform.

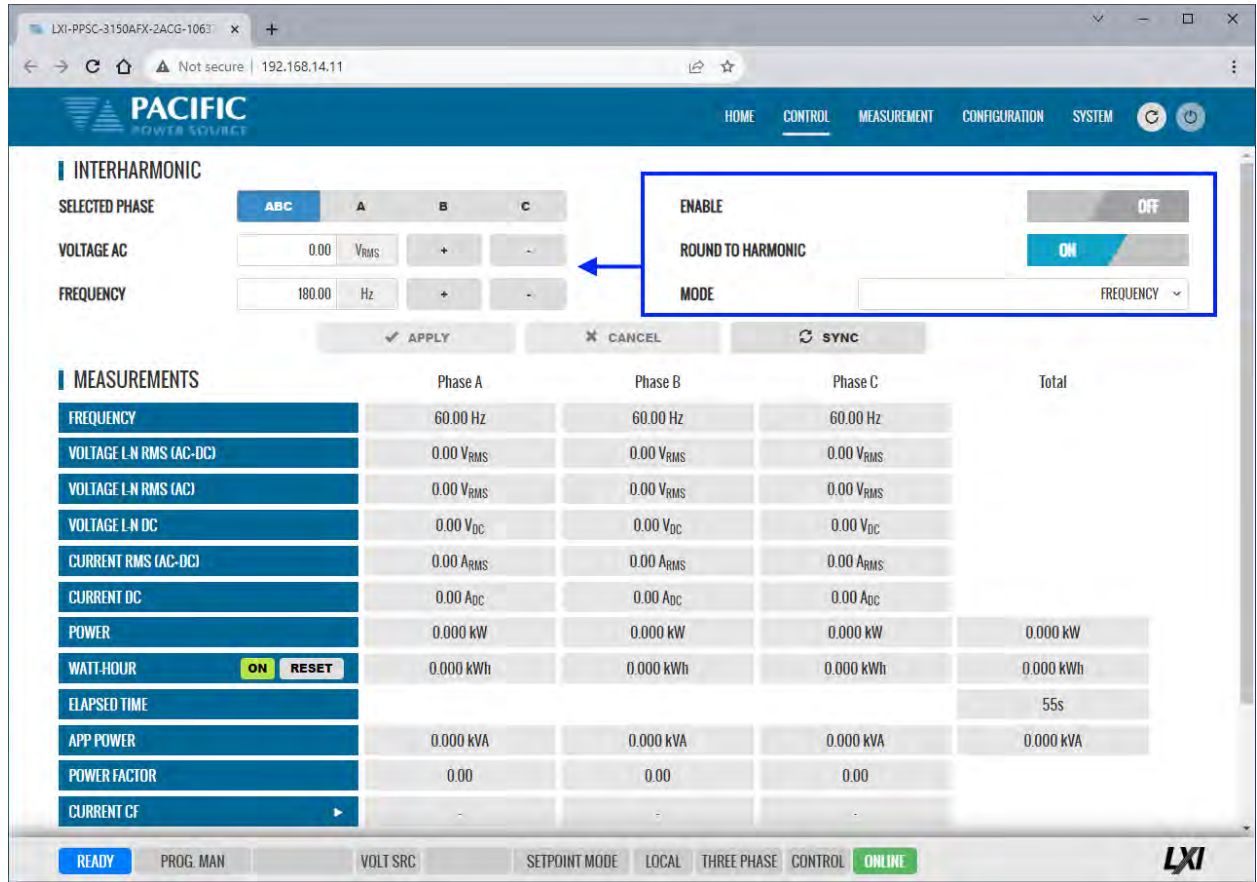

Note 1: Interharmonics are only available and visible if the -413 Interharmonics option is installed. If installed, a “C” will be appended to the AFX model number.

10.7.5 Program Memory

Program settings and transients can be stored in a number of different memory types. The Program Memory screen allows the user to manage available stored programs. The program to be recalled on power up can be selected at the bottom of this screen in the “POWER ON PROGRAM” area.

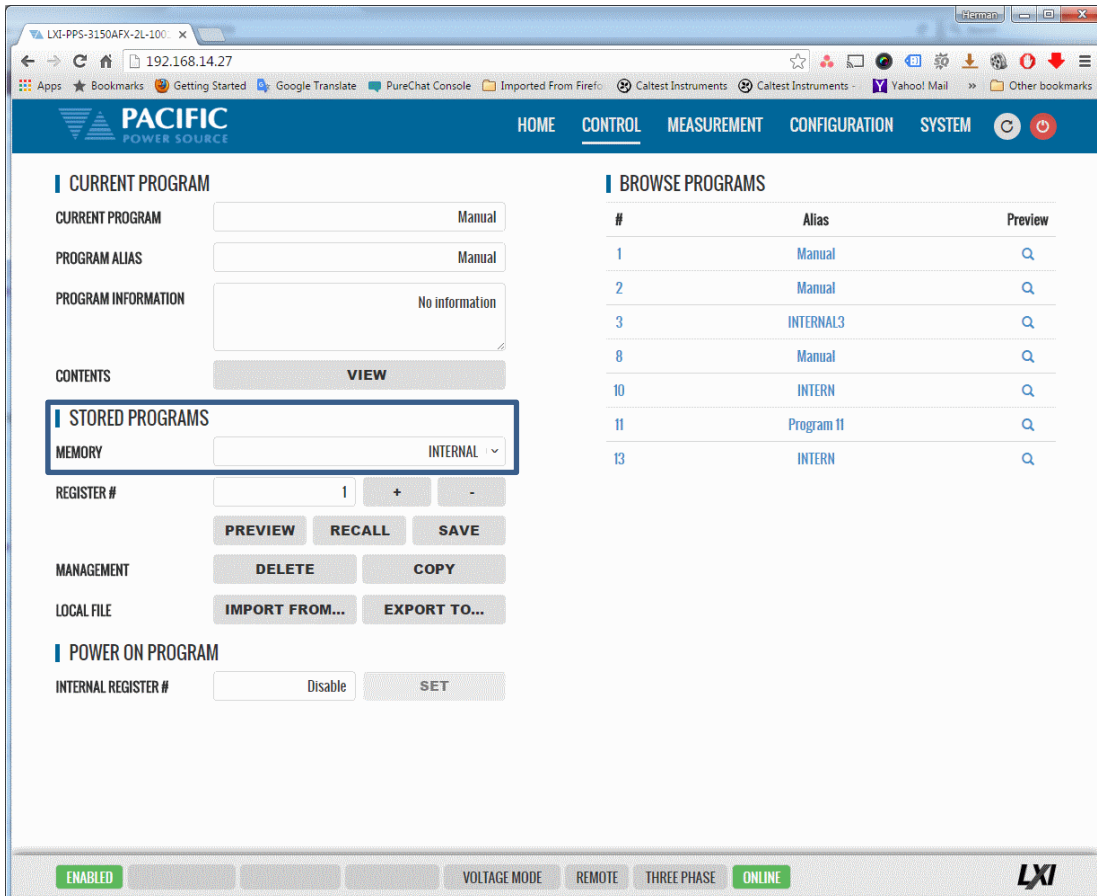

Note that external storage devices may be selected under “STORED PROGRAMS” using the MEMORY drop down list control.

10.7.6 Waveform

The power source supports a number of waveforms, most of which are user programmable arbitrary waveforms. The Waveform screen may be used to preview, select and download any of the waveforms stored in internal memory for output on one or more phases. The phase selection “ABC” or separate “A:”, “B” and “C” buttons on the upper right hand side are used to select all or an individual phase. The WAVEFORM drop down list will show all available waveforms.

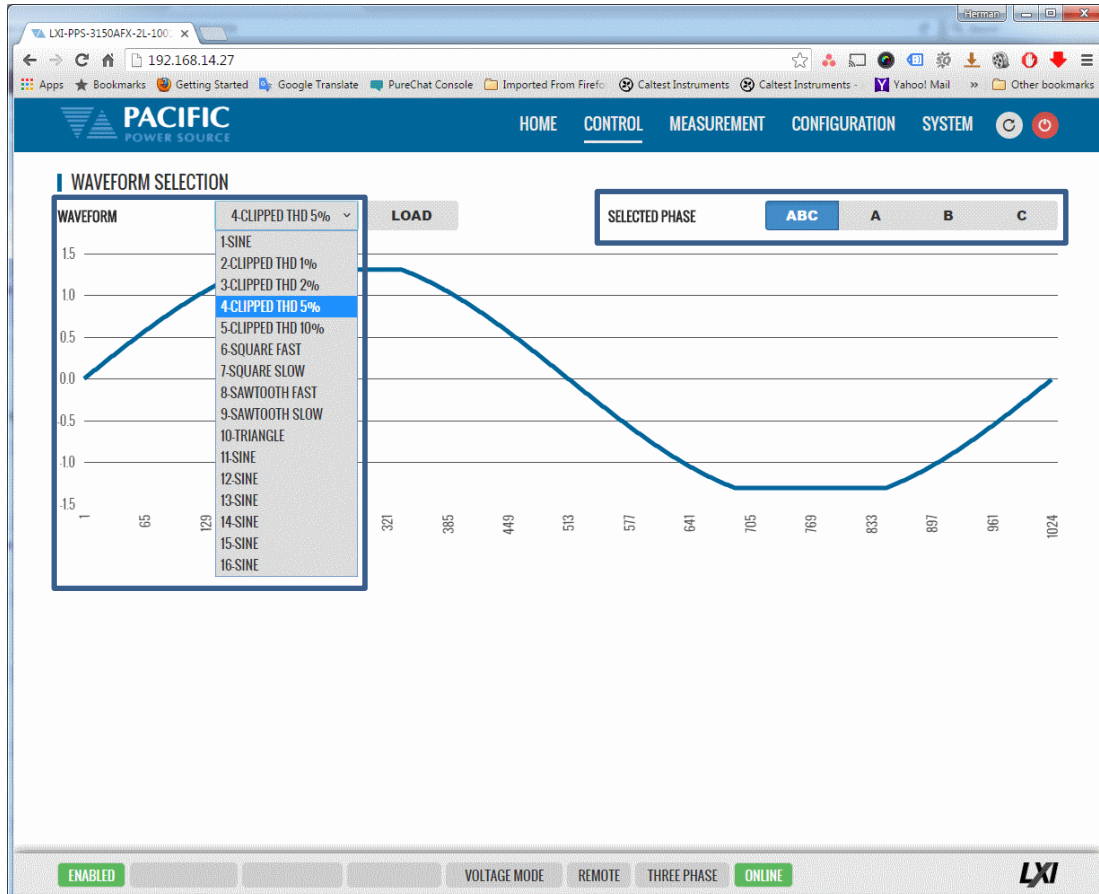

In addition to selecting the active waveform for output, the following controls are available to manage waveforms:



CONTROL	Purpose
IMPORT....	Import csv format waveform data files.
EXPORT...	Export selected waveform to csv format file
EDIT...	Access Waveform Edit screen to edit selected waveform. Also available from the CONTROL pull-down menu.
DELETE	Delete selected waveform. Note: Waveform 1-SINE cannot be deleted.
NEW...	Access the Waveform Edit screen to create a new waveform in the browser.

10.7.7 Waveform Editor

The waveform Editor function allows creation of custom waveforms. Each waveform records consists of 1024 data points (0.35° resolution). Data points can be indexed in Degrees or points. A value can be entered for each data point. There are several tools to generate harmonics, sum to a base sine wave or import a .csv file.

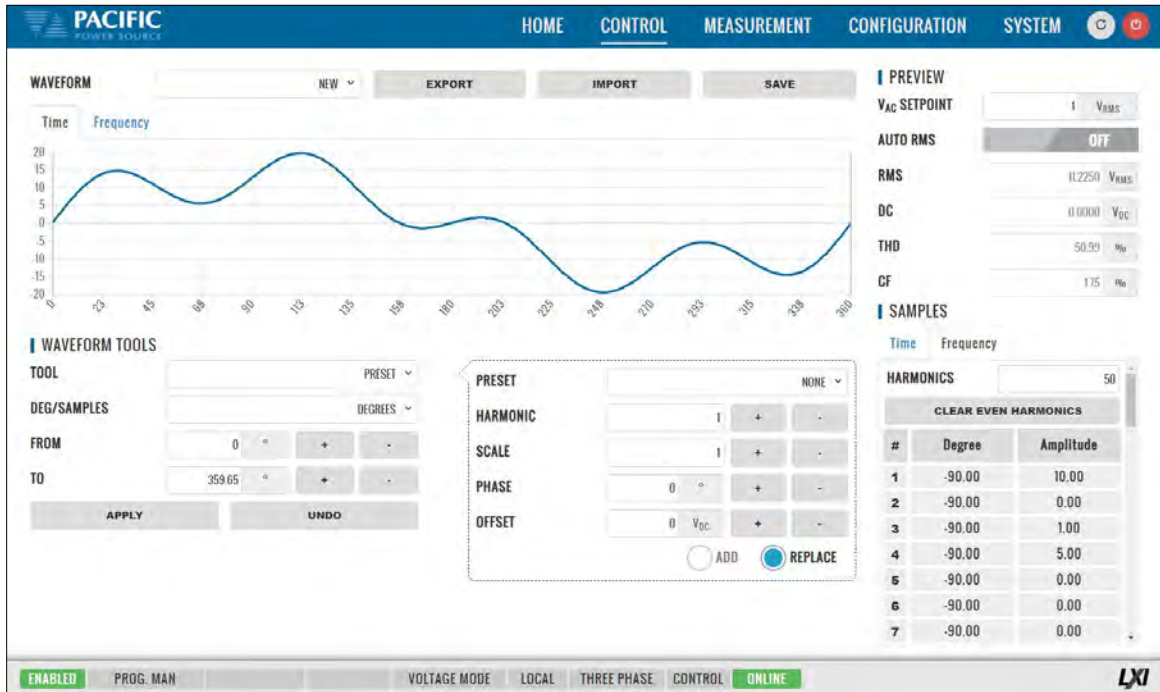

The following tools and controls are available in the Waveform Edit screen:

CONTROL	Purpose
WAVEFORM	Selects any available waveform to edit or select NEW to create a new waveform.
EXPORT	Export selected waveform to csv format file
IMPORT	Import csv format waveform data files.
SAVE	Saves selected waveform to power source memory
SAMPLES	Select no of data points used to defined wave shape. Available settings are 1024 through 2. For best definition, use 1024 data points. Lower point selections will result in interpolation of points in between. All waveforms are stored at 1024-point resolution. See examples on next page.
PREVIEW	
	Vac SETPOINT: Scales vertical axis to show voltage levels.
	AUTO RMS: Scales waveform levels to maintain Vac RMS value specified.
	RMS: Targeted Vac RMS level.
	THD: Shows total harmonic distortion in % of fundamental H1 for voltage waveform.
	DC: Targeted DC offset
	CF: Shows Crest Factor of voltage waveform.

10.7.7.1 Data Points

Waveform creation using direct data entry for each data point is faster when using fewer data points. Examples below show sine wave creation using either 16 or 4 data points. However, data is interpolated linearly for points not displayed in the table on the right hand side.

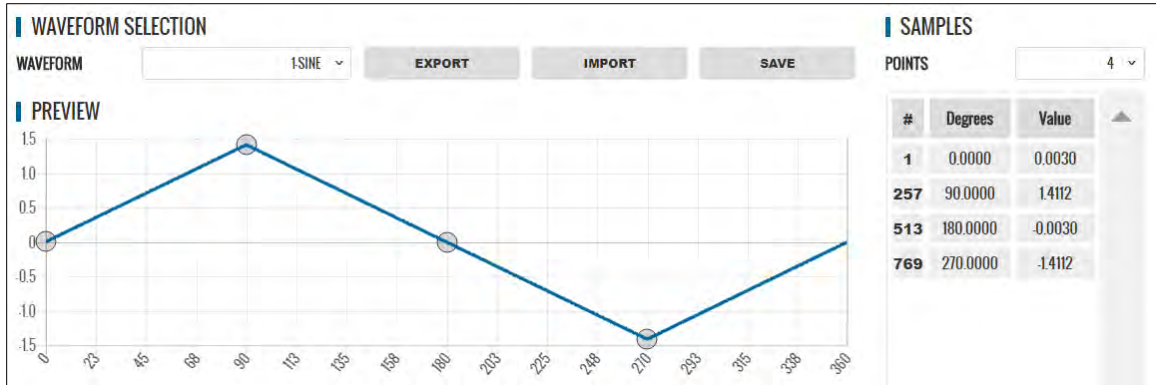

Figure 10-5: Waveform Edit defined using 4 data points

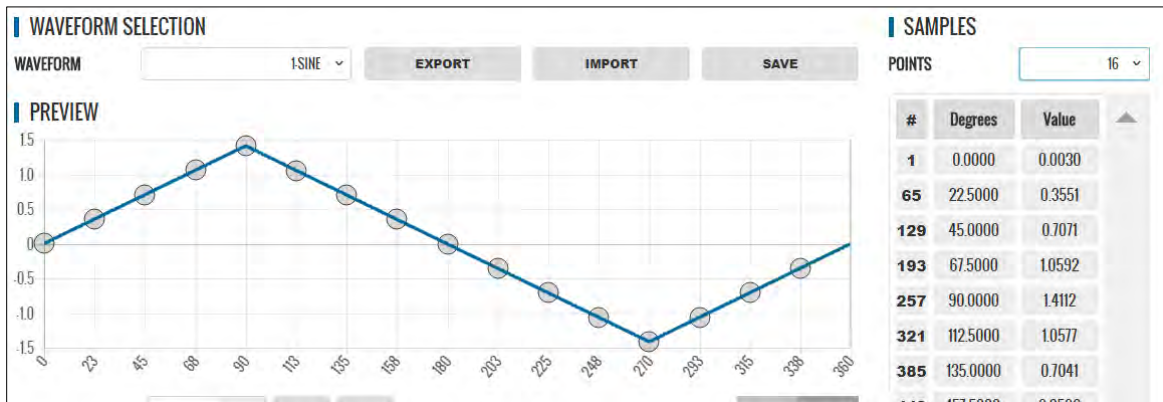

Figure 10-6: Waveform Edit defined using 16 data points

10.7.7.2 Waveform Tools

The following Waveform Tools are available:

CONTROL	Purpose
TOOLS	<p>These selections created specific waveform types without having to define data values manually. Following functions are available from this drop-down:</p> <p>NORMALIZE Normalizes waveform for zero DC offset.</p> <p>RECTIFY Rectifies the waveform. Only positive data points remain. This implies a DC offset which is shown in the DC display field below the graph.</p> <p>FREQ MULTIPLY Creates specified number of periods to multiply fundamental frequency. Use caution with resulting higher frequency waveforms as power source has a finite bandwidth and output may fault if too much high frequency content is present.</p> <p>OFFSET Applies specified DC offset.</p> <p>SCALE Multiplies all data points by scale factor value.</p> <p>VERTICAL FLIP Flips waveform vertically.</p> <p>HORIZONTAL FLIP Flips waveform horizontally.</p> <p>SMOOTHING FILTER Smooths sharp edges to reduce bandwidth requirements.</p> <p>PRESET Selects built-in waveform types based on user parameters.</p>
PRESETS	<p>The following PRESET waveforms are available:</p> <p>NONE Default or no selection made.</p> <p>SINE, TRIANGLE, SQUARE, 6 STEPS, 12 STEPS, SINE POWER, CLIPPED SINE, SAWTOOTH, PULSE, IMPORTED WAVEFORM</p>
PARAMETERS	<p>The following parameters are settable for each PRESET selection:</p> <p>HARMONIC H1 through H32</p> <p>SCALE Vertical Scale Multiplier</p> <p>PHASE Start phase angle</p> <p>OFFSET DC Offset</p> <p>EXPONENT 1 through 51. Applies to SINE POWER present only.</p> <p>THD 0% through 100%. Applies to CLIPPED SINE only.</p> <p>RISE TIME 0° through 360°. Applies to PULSE preset only.</p> <p>PULSE WIDTH 0° through 360°. Applies to PULSE preset only.</p> <p>FALL TIME 0° through 360°. Applies to PULSE preset only.</p> <p>LOAD FROM FILE Available for IMPORTED WAVEFORM preset only.</p> <p>ADD Add to existing waveform (summation)</p> <p>REPLACE Replace existing waveform with selected PRESET</p>

Example for UL 2231-2 Ringwave Test Waveform Creation.

This immunity test superimposes a decaying sine amplitude on an AC 50Hz or 60Hz line voltage at frequencies of 1kHz, 2kHz, 3kHz, 4kHz and 5kHz. This example shows how to add the 5kHz ring wave to a standard sinewave voltage using the Waveform Editor in the web browser interface.

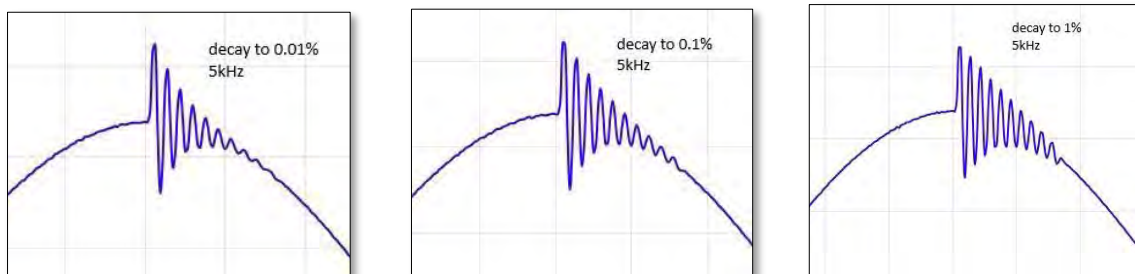

From the Tools menu on the left, select the **RING WAVEFORM** type. The following parameters can be set to create the desired ring wave voltage waveform:

- DECAY:** Represents the decay constant based on the final amplitude value of the ringing signal (1%, 0.1% or 0.01%) of the initial amplitude.
- RING FRQUENCY** This is the frequency multiplier of the base frequency.
- RING AMPLITUDE** This is the (Ringing initial amplitude/Base signal amplitude) ratio.
- DEG (FROM / TO)** Determines the phase angle for the start and end of the ringing signal, as shown in this example, 126-90=36 which is 10% Of the 360° period.



The waveform created using the editor can be downloaded to the power source using the **SAVE** button. Once loaded, the internal advanced scope function in the web browser interface can be used to capture the actual output waveform as shown below.



10.7.8 Test Sequence

The test sequence feature can be found on the webpage CONTROL menu under “TEST SEQUENCE”. **Note** that this function requires firmware revision 3.7.x or higher.

CONTROL -> TEST SEQUENCE.

It is off by default to save unit memory and takes a few seconds to start once the Test Sequence screen is open the first time after power on.

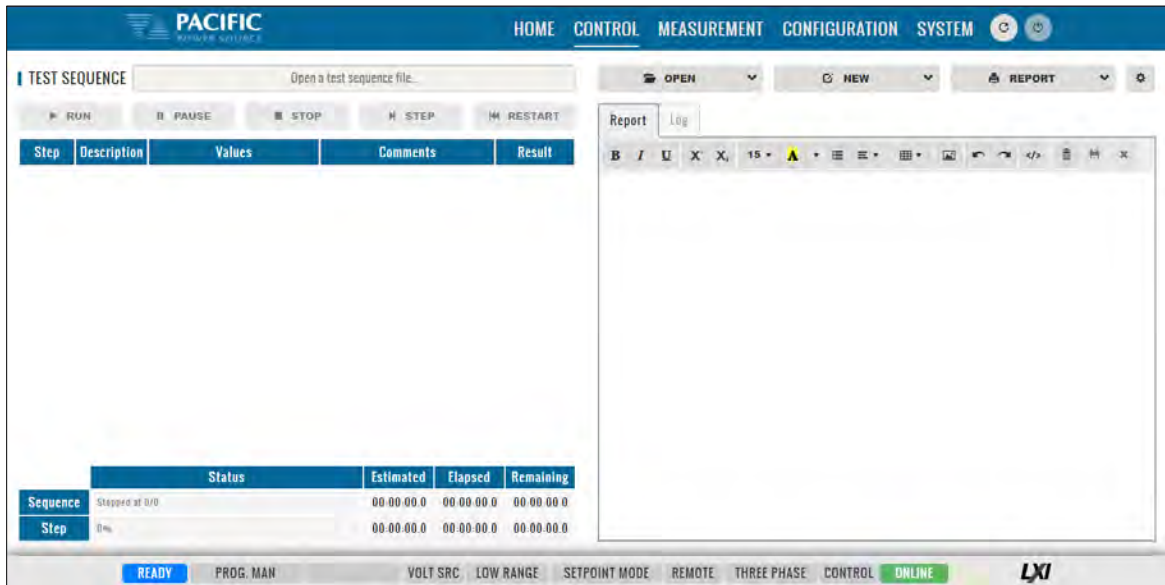

A Test Sequence consists of a group of steps that are executed sequentially. Each step logs the details of said step to a test report. After test execution, this test report can be downloaded or printed using the browser interface.

A Test Sequence step can be any of the following types:

- Configuration
- Steady state
- Transient
- Timer (To perform a delay)
- User prompt (Show information)
- Meter (Performs different measurements)
- Control (Power source control shortcut)
- User input
- Script (For custom procedures, the coding language is Javascript)
- SCPI list (Executes a list of SCPI commands)
- SCPI (Executes a SCPI command)

Note that the sequence engine runs on the power source controller. The browser based webpage only acts as the graphical user interface for test sequence development, execution and reporting. As such, the browser can be closed and reopened without losing any of the test sequence information.

The test sequence functions can also be fully controlled remotely using SCPI commands and the sequences can be stored in the power sources' nonvolatile flash memory. The file format is the industry standard 7z extension compressed file format.

To familiarize yourself with test sequence use and operation, it is recommended to study the four example files provided:

- Sample-test-1.7z
- Sample-test-2.7z
- Sample-test-3.7z
- Sample-test-4.7z

For example, sample-test number 4 performs an IEC 61000-4-11 short voltage interrupt test on any number of user selectable phases. It's content is shown in the browser screen below.

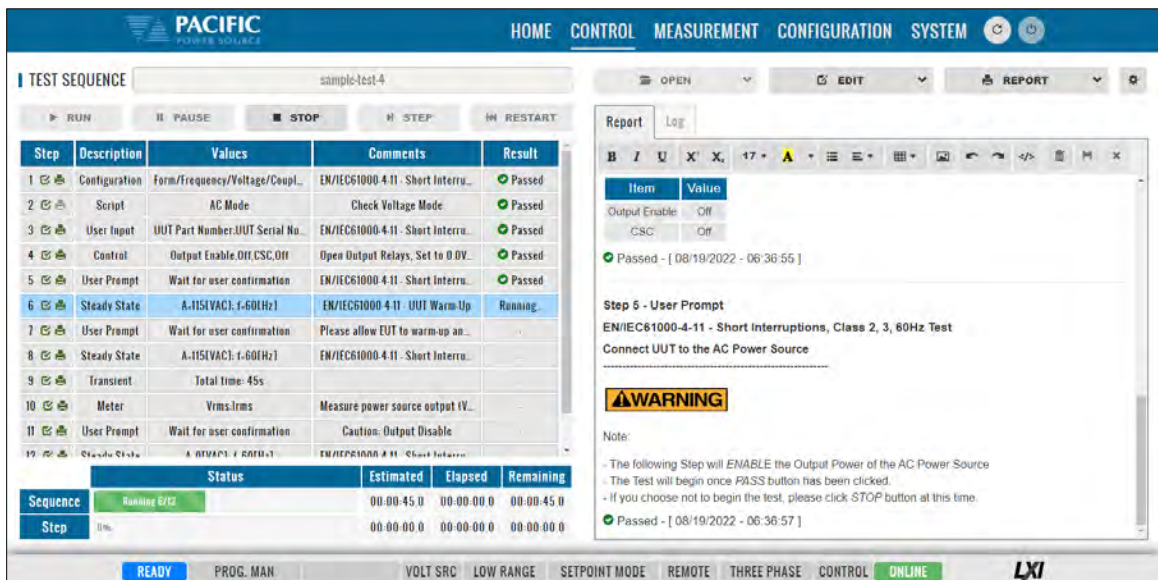

Step	Description	Values	Comments	Result
1	Configuration	Form/Frequency/Voltage/Coupl...	EN/IEC61000-4-11 - Short Interru...	Passed
2	Script	AC Mode	Check Voltage Mode	Passed
3	User Input	UUT Part Number,UUT Serial No.	EN/IEC61000-4-11 - Short Interru...	Passed
4	Control	Output Enable,Off,CSC,Off	Open Output Relays, Set to 0.0V.	Passed
5	User Prompt	Wait for user confirmation	EN/IEC61000-4-11 - Short Interru...	Passed
6	Steady State	A-115(VAC), f-60(Hz)	EN/IEC61000-4-11 - UUT Warm Up	Running
7	User Prompt	Wait for user confirmation	Please allow EUT to warm-up an...	
8	Steady State	A-115(VAC), f-60(Hz)	EN/IEC61000-4-11 - Short Interru...	
9	Transient	Total Time- 45s		
10	Meter	Vrms,Irms	Measure power source output IV...	
11	User Prompt	Wait for user confirmation	Caution: Output Disable	

Sequence	Status	Estimated	Elapsed	Remaining
Sequence	Running 67%	00:00:45.0	00:00:00.0	00:00:45.0
Step	11%	00:00:00.0	00:00:00.0	00:00:00.0

Report Log

Item	Value
Output Enable	Off
CSC	Off

Passed - [08/19/2022 - 06:36:55]

Step 5 - User Prompt
EN/IEC61000-4-11 - Short interruptions, Class 2, 3, 60Hz Test
Connect UUT to the AC Power Source

WARNING

Note:

- The following Step will **ENABLE** the Output Power of the AC Power Source
- The Test will begin once **PASS** button has been clicked.
- If you choose not to begin the test, please click **STOP** button at this time.

Passed - [08/19/2022 - 06:36:57]

For an overview of the available Test Sequence SCPI control command syntax, refer to the Remote Control Programming Section of this manual. (Section 8.11).

10.7.9 SCPI Script

The SCPI Script menu entry displays the command scripting screen. These user generated scripts can contain any sequence of SCPI commands, comments and output statements to automate simple repetitive tasks. Scripts may be used to automate repetitive tasks more quickly and are simpler to write than an actual application program.

A script can be saved to the PC or tablet on which the browser runs.

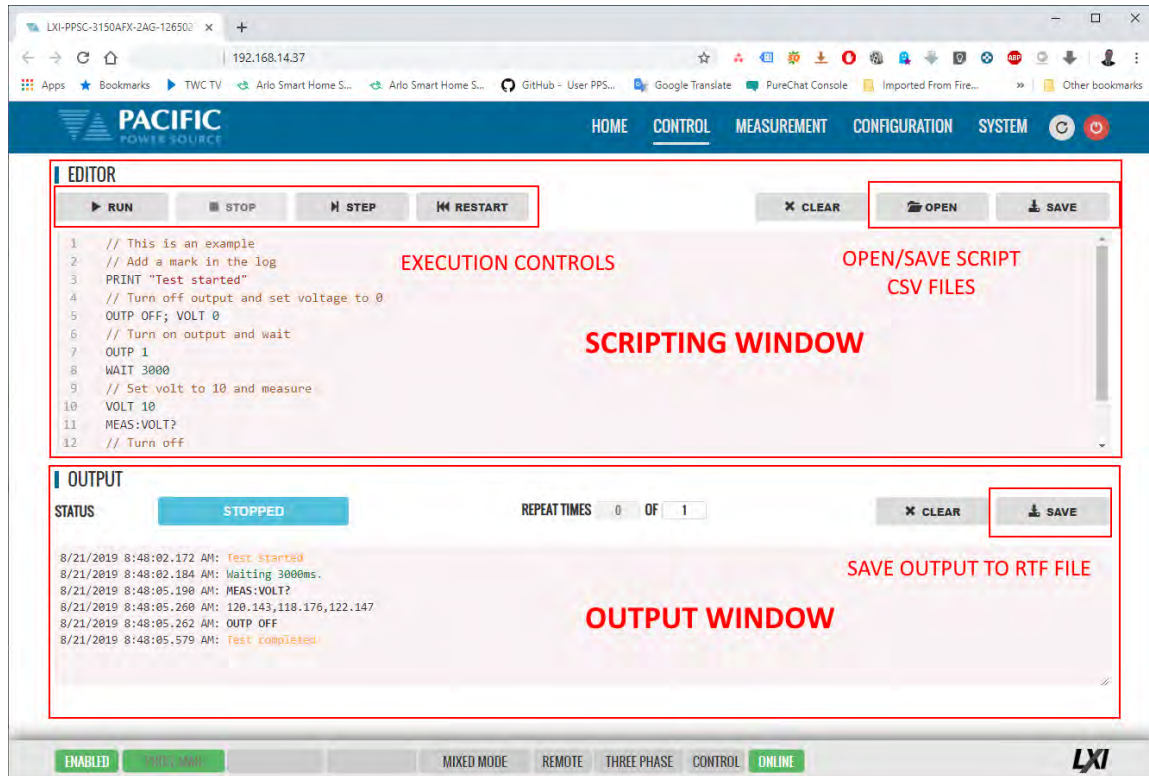

10.7.9.1 Supported Keywords and Commands

The following script entries are supported:

Entry Type	Description
USER COMMENT	// Any test preceded by a two forward slash characters
PRINT	Sends text strings after PRINT key word to the OUTPUT window located at the bottom half of the browser window.
WAIT	Pauses script execution by no of msec specified.
SCPI COMMAND	Any support SCPI command. Data returned by a query command (?) will be printed in the output window.

Table 10-1: Supported Script Entries

10.7.9.2 Script Execution Control

To run a script, click the **RUN** button in the upper left corner of the Editor window. You can also single step through a script during development using the **STEP** button. The **STOP** button will abort execution of a running script. To run a script multiple times, set the **REPEAT TIMES** value to a value higher than the default 1 (one). Max. repeat count is 1e+54.

10.7.9.3 Managing multiple script files.

Script files can be saved to the PC or device on which the browser runs, i.e. Windows PC, Tablet, or Smartphone. Use the **OPEN** and **SAVE** buttons in the upper right corner of the Editor window to save and retrieve scripts. Scripts are saved in Comma Separated File format, which can be edited in Excel or any text editor like Notepad. The sample script csv file content (*scpi_script.csv*) is shown below. When saving a new script, replace the default scpi_script file name with a more descriptive file name.

```
// Available commands are:  
// - WAIT MILLISECONDS, example -> WAIT 2000  
// - PRINT "TEXT", example -> PRINT "Test started"  
// - SCPI COMMAND/s, example -> OUTP OFF; VOLT 0  
// Comments starts with // as this line  
// The following is an example  
// Add a mark in the log  
PRINT "Test started"  
// Turn off output and set voltage to 0  
OUTP OFF; VOLT 0  
// Turn on output  
OUTP 1  
// Wait three seconds  
WAIT 3000  
// Set output voltage to 10 volts  
VOLT 10  
// Get output voltage measurement  
MEAS:VOLT?  
// Turn off  
OUTP OFF  
PRINT "Test completed"
```

10.7.9.4 Script Execution Output

The OUTPUT window located in the bottom half of the browser window shows all script output, including any user comments, events like script start and stop as well as any PRINT commands. Each output entry is date and time stamped.

The content of the **OUTPUT** window can be saved to a Rich Text File using the **SAVE** button in the upper right corner of the OUTPUT window. (Do not confuse with the SAVE button in the script EDITOR window.) The default output file name is "*scpi_script_output.rtf*". A sequence number (1), (2) etc will be appended each time the output window content is saved.

A sample RFT file is shown below.

```
8/21/2019 8:48:02.172 AM: Test started  
8/21/2019 8:48:02.184 AM: Waiting 3000ms.  
8/21/2019 8:48:05.190 AM: MEAS:VOLT?  
8/21/2019 8:48:05.260 AM: 120.143,118.176,122.147  
8/21/2019 8:48:05.262 AM: OUTP OFF  
8/21/2019 8:48:05.579 AM: Test completed
```

Note: All output files are saved to the default Download directory determined by the Browser setting.

10.8 Measurement Screens

The MEASUREMENT menu provides access to several measurement screens. Measurement screens available are:

- MONITOR
- REAL TIME PLOT
- WAVEFORMS
- V/I PLOT
- HARMONICS
- DATALOGGER
- SCOPE
- HARMONICS

Each is described in subsequent sections.

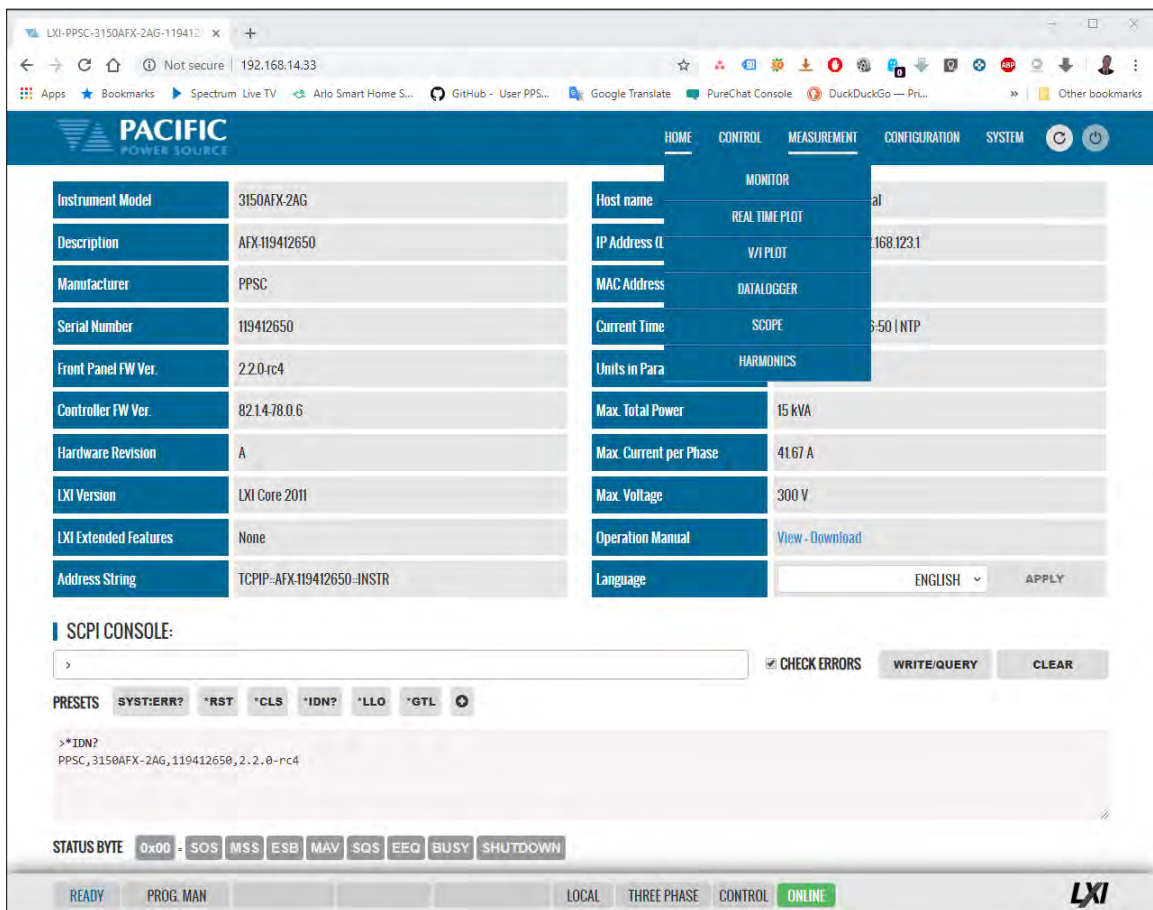

The screenshot shows the web interface for the LXI-PPSC-3150AFX-2AG-119412650 power source. The browser address bar shows the IP address 192.168.14.33. The interface has a blue header with the Pacific Power Source logo and navigation tabs: HOME, CONTROL, MEASUREMENT, CONFIGURATION, and SYSTEM. The MEASUREMENT menu is open, showing options: MONITOR, REAL TIME PLOT, V/I PLOT, DATALOGGER, SCOPE, and HARMONICS. Below the menu, there are two columns of data. The left column lists instrument details: Instrument Model (3150AFX-2AG), Description (AFX119412650), Manufacturer (PPSC), Serial Number (119412650), Front Panel FW Ver. (2.2.0-rc4), Controller FW Ver. (82.14.78.0.6), Hardware Revision (A), LXI Version (LXI Core 2011), LXI Extended Features (None), and Address String (TCPIP:AFX-119412650-INSTR). The right column shows measurement data: Host name, IP Address (192.168.123.1), MAC Address, Current Time (15:50 | NTP), Units in Para, Max. Total Power (15 kVA), Max. Current per Phase (41.67 A), Max. Voltage (300 V), Operation Manual (View - Download), and Language (ENGLISH). Below the data is the SCPI console with a text input field, a 'CHECK ERRORS' checkbox, and buttons for 'WRITE/QUERY' and 'CLEAR'. The console shows the command '>*IDN?' and the response 'PPSC, 3150AFX-2AG, 119412650, 2.2.0-rc4'. At the bottom, there is a 'STATUS BYTE' section with buttons for 0x00, SOS, MSS, ESB, MAV, SQS, EEQ, BUSY, and SHUTDOWN. The bottom status bar shows 'READY', 'PROG. MAN', 'LOCAL', 'THREE PHASE', 'CONTROL', and 'ONLINE' (highlighted in green), along with the LXI logo.

10.8.1 Monitor

The measurement monitor screen replicates part of the CONTROL->PROGRAM screen and displays all measurement data for all available output phases. Measurements include both AC and DC components depending on selected operating mode.

Note: There are no controls on this screen.



MEASUREMENTS	Phase A	Phase B	Phase C
FREQUENCY	50.00 Hz	50.00 Hz	50.00 Hz
VOLTAGE L-N RMS (AC-DC)	100.00 V _{RMS}	100.00 V _{RMS}	100.00 V _{RMS}
VOLTAGE L-N RMS (AC)	100.00 V _{RMS}	100.00 V _{RMS}	100.00 V _{RMS}
VOLTAGE L-N DC	0.00 V _{DC}	0.00 V _{DC}	0.00 V _{DC}
CURRENT RMS (AC-DC)	4.96 A _{RMS}	5.12 A _{RMS}	5.10 A _{RMS}
CURRENT DC	0.22 A _{DC}	0.21 A _{DC}	0.09 A _{DC}
POWER	0.496 kW	0.512 kW	0.509 kW
WATT-HOUR RESET	0.010 kWh	0.010 kWh	0.010 kWh
APP POWER	0.496 kVA	0.512 kVA	0.510 kVA
POWER FACTOR	1.00	1.00	1.00
CURRENT CF ▼	1.47	1.46	1.44
PEAK CURRENT	7.27 A	7.48 A	7.33 A
RECORDED PEAK CURRENT RESET	7.48 A	-8.94 A	8.78 A
	V _{AB}	V _{BC}	V _{CA}
VOLTAGE L-L RMS (AC-DC)	173.21 V _{RMS}	173.21 V _{RMS}	173.21 V _{RMS}
VOLTAGE L-L RMS (AC)	173.21 V _{RMS}	173.21 V _{RMS}	173.21 V _{RMS}
VOLTAGE L-L DC	0.00 V _{RMS}	0.00 V _{RMS}	0.00 V _{RMS}

ENABLED PROG. MAN VOLTAGE MODE REMOTE THREE PHASE CONTROL ONLINE LXI

10.8.2 Real-Time Plot

This measurement screens provides a strip-chart style graphical display for up to two measurement parameters, #1 and #2. The CONTROLS are allows selection of the desired parameter for each graph. Available choices are Voltage, Current and Power. Depending on phase mode, up to three phase values are displayed per chart.

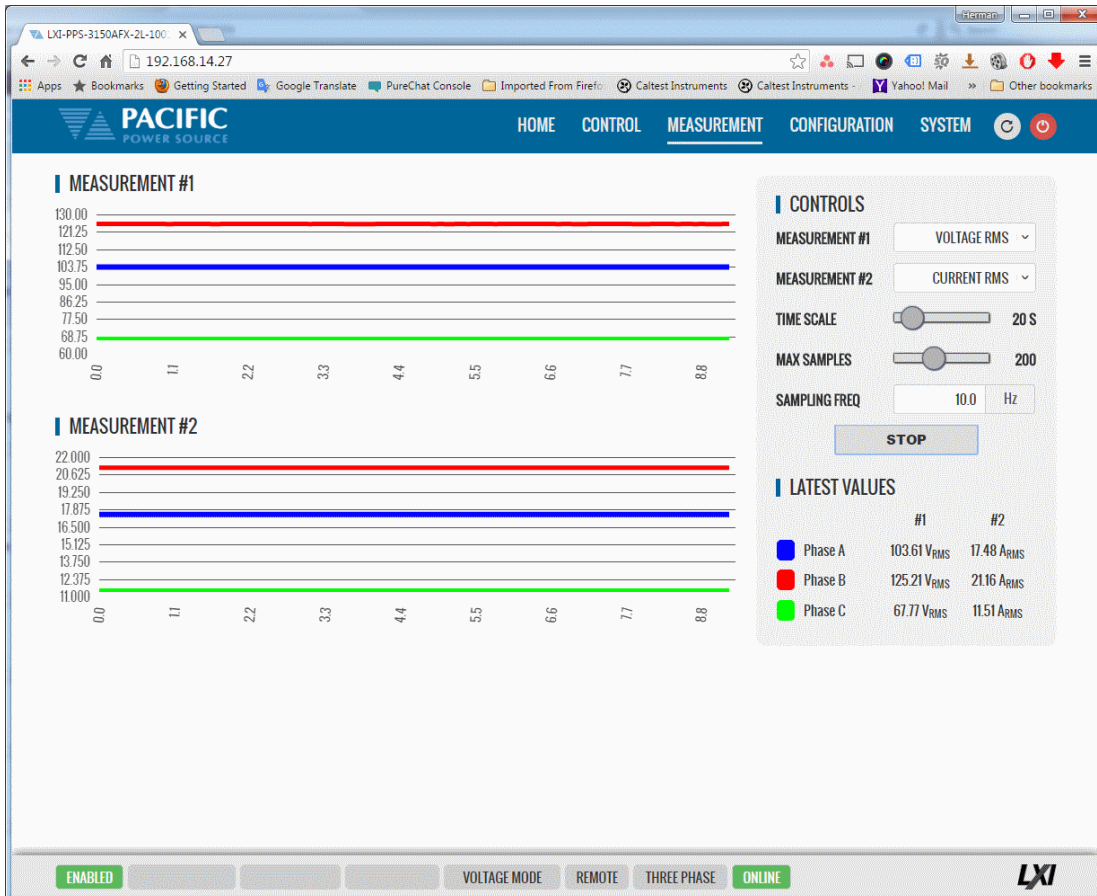

10.8.3 V/I Plot

The V/I plot shows the power operating point at any moment in time by plotting measured Voltage as a function of measured Current. This plot has a persistence mode so the user can observe power fluctuations and changes over a set period.



Available selections in this measurement screen are:

- Persistence Time: 1 ~ 60 sec

10.8.4 Data Logger

The measurement data logger screen allows measurement data to be written to a memory device, using a comma delimited file format. These files are easy to open in an Excel™ spreadsheet or other math oriented software program.

Available controls are for State on/off, memory destination device, file name assignment and data logging rate in Hz. All file entries are time stamped.

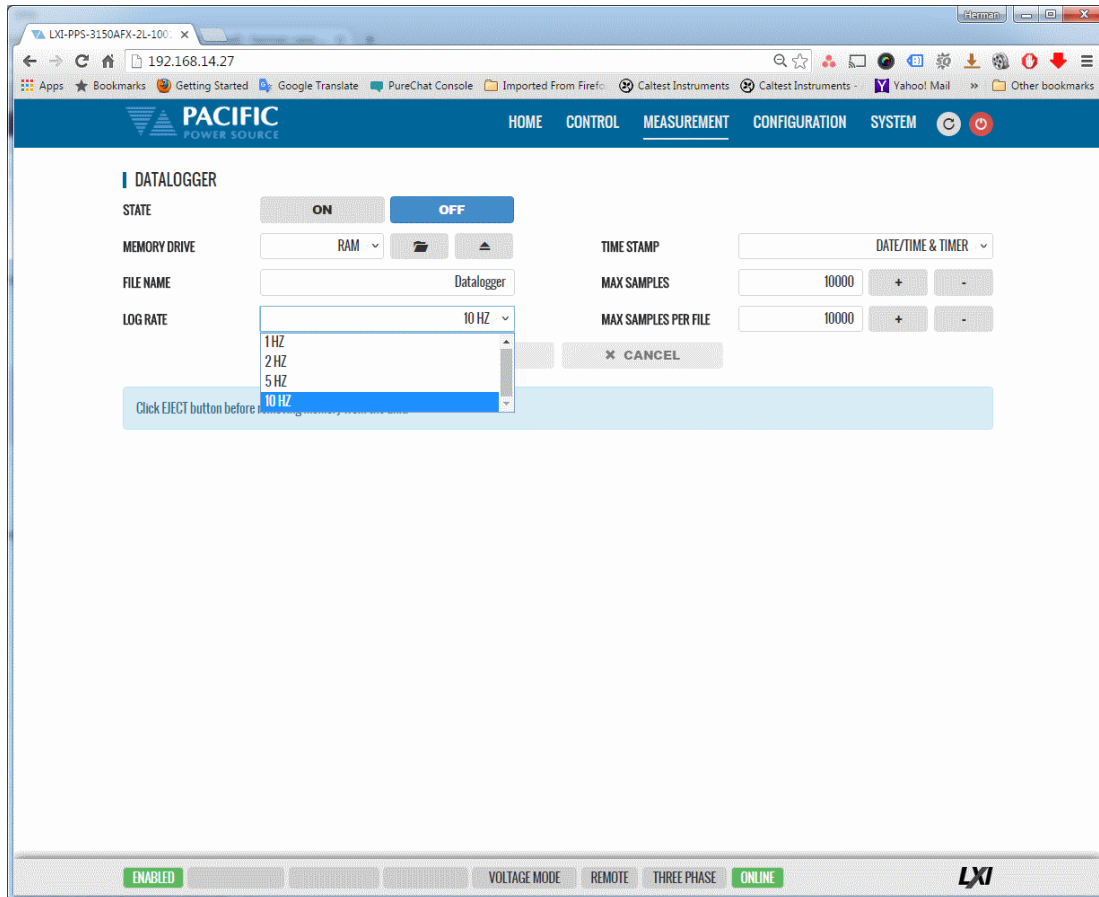

10.8.5 Scope

The Scope function captures voltage and current waveforms at the output of the power source on all phases. This screen allows a variety of captured waveforms to be displayed.



The following controls are available to customize the captured waveform display:

CONTROL	Purpose
MEASUREMENT	Selects Voltage L-N, Voltage L-L, Current or Both Voltage & Current
PHASE	Selects Phase A, B, C or all (ABC). Only visible in two or three phase mode.
TIME UNIT	Selects time scale in either TIME, SAMPLES or PHASE
PERIODS	Selects the number of periods to display. Range is 1~ 4
AUTO REFRESH	Turns AUTO REFRESH mode ON or OFF
REFRESH PERIOD	Sets interval time for AUTO REFRESH mode in seconds. Range is 5 ~ 100.
REFRESH	Manual REFRESH button
EXPORT GRAPH	Downloads image for displayed waveform(s). See sample below.
EXPORT DATA	Downloads captured data points for displayed waveform(s) in csv format text file. See sample below.

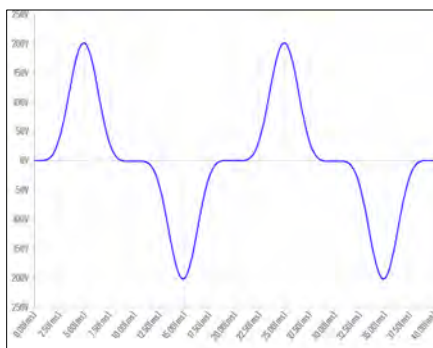

Sample	Degrees	Time[s]	Phase A - Voltage[V]
1	0	0	-0.12
2	0.7	3.91E-05	0.05
3	1.41	7.81E-05	0.02
4	2.11	0.000117	-0.1
5	2.81	0.000156	-0.03
6	3.52	0.000195	0

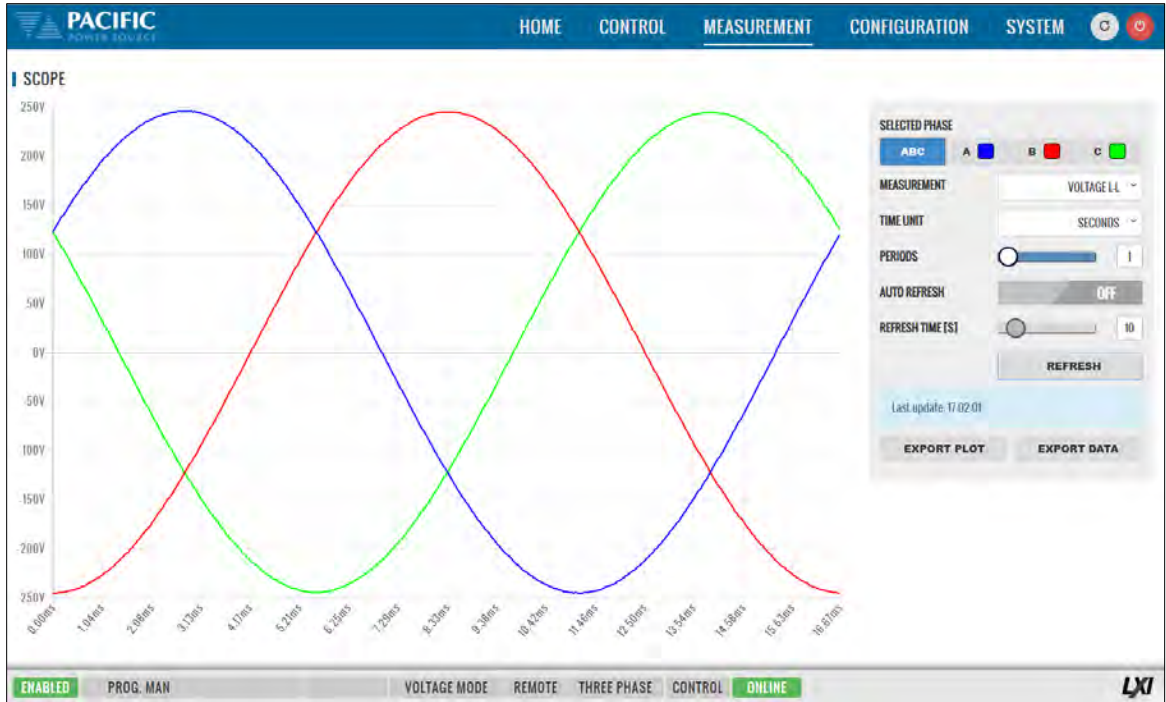

Line to Line Capture for all phases.

Voltage and Current can be displayed in one scope screen:

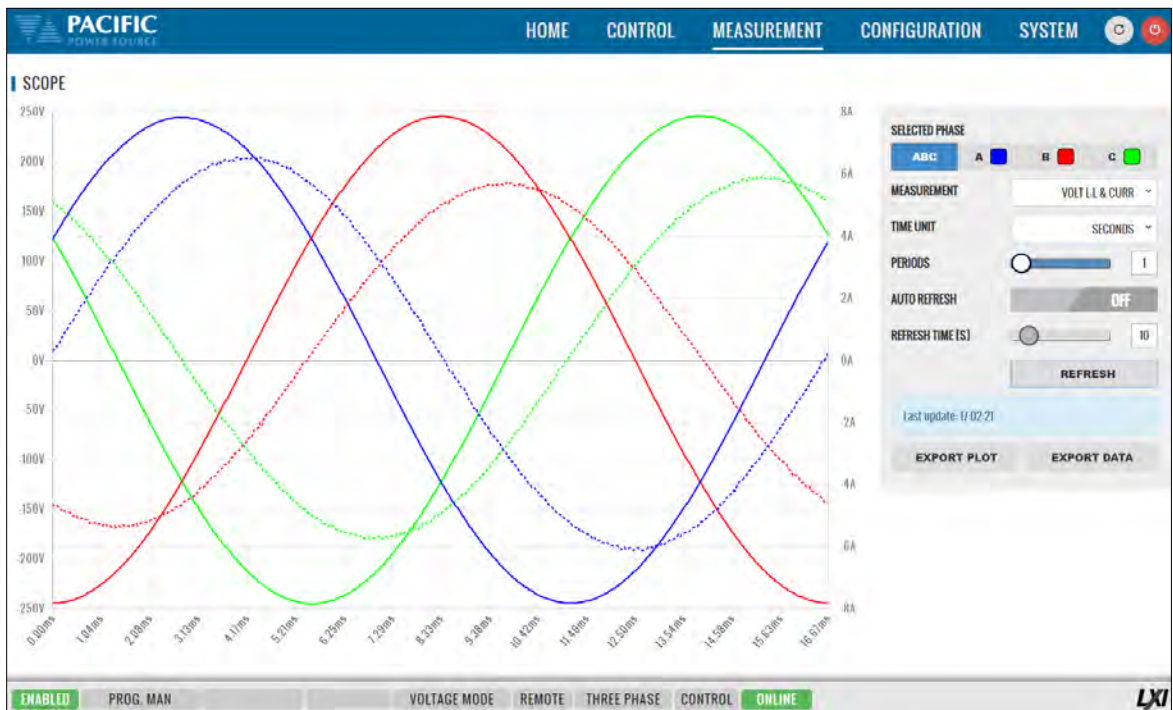

10.8.6 Harmonics

Harmonics measurements for voltage and current on all phases can be displayed using the Harmonics display screen as illustrated below. Both Bar Chart and Table displays are shown. The distortion values for the parameter selected (Voltage or Current) are display in a table directly below the Bar chart area.

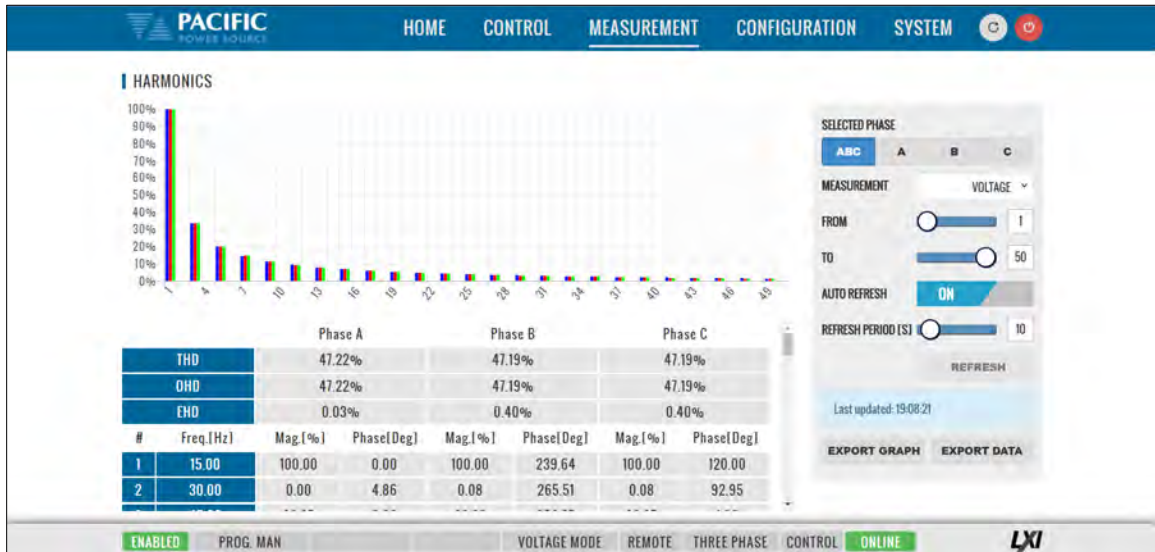

Available selections in this measurement screen are:

CONTROL	Purpose
SELECTED PHASE	
MEASUREMENT TYPE	Selects Voltage L-N, Voltage L-L, Current or Both Voltage & Current
FROM	Selects the first harmonic number to display. Range is 1 ~ 49
TO	Selects the last harmonic number to display. Range is 2 ~ 50
AUTO REFRESH	Turns AUTO REFRESH mode ON or OFF
REFRESH PERIOD	Sets interval time for AUTO REFRESH mode in seconds. Range is 5 ~ 100.
REFRESH	Manual REFRESH button
EXPORT GRAPH	Downloads image for displayed Bar chart. See sample below.
EXPORT DATA	Downloads captured harmonics data in csv format text file. See sample below.

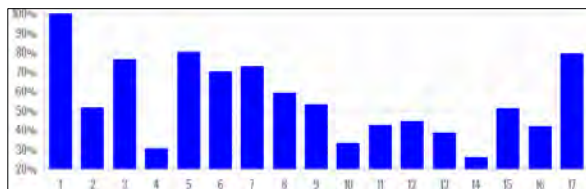

Measurement	Phase A[%]		
THD	455.98		
OHD	354.89		
EHD	286.32		
#	Freq.[Hz]	Phase A Mag.[%]	Phase A Phase.[Deg]
1	50	100	75.89
2	100	51.72	60.61
3	150	76.38	70.94
4	200	30.75	329.44
5	250	80.49	243.12
6	300	70.33	18.6
7	350	72.99	257.95
8	400	59.41	268.51

10.9 Configuration Screens

The CONFIGURATION menu provides access to secondary power source settings that are less frequently changed than those on the PROGRAM screen. Configuration screens available are:

- UNIT SETTINGS
- USER LIMITS & PRESETS
- RAMP & SLEW

Each is described in subsequent sections.

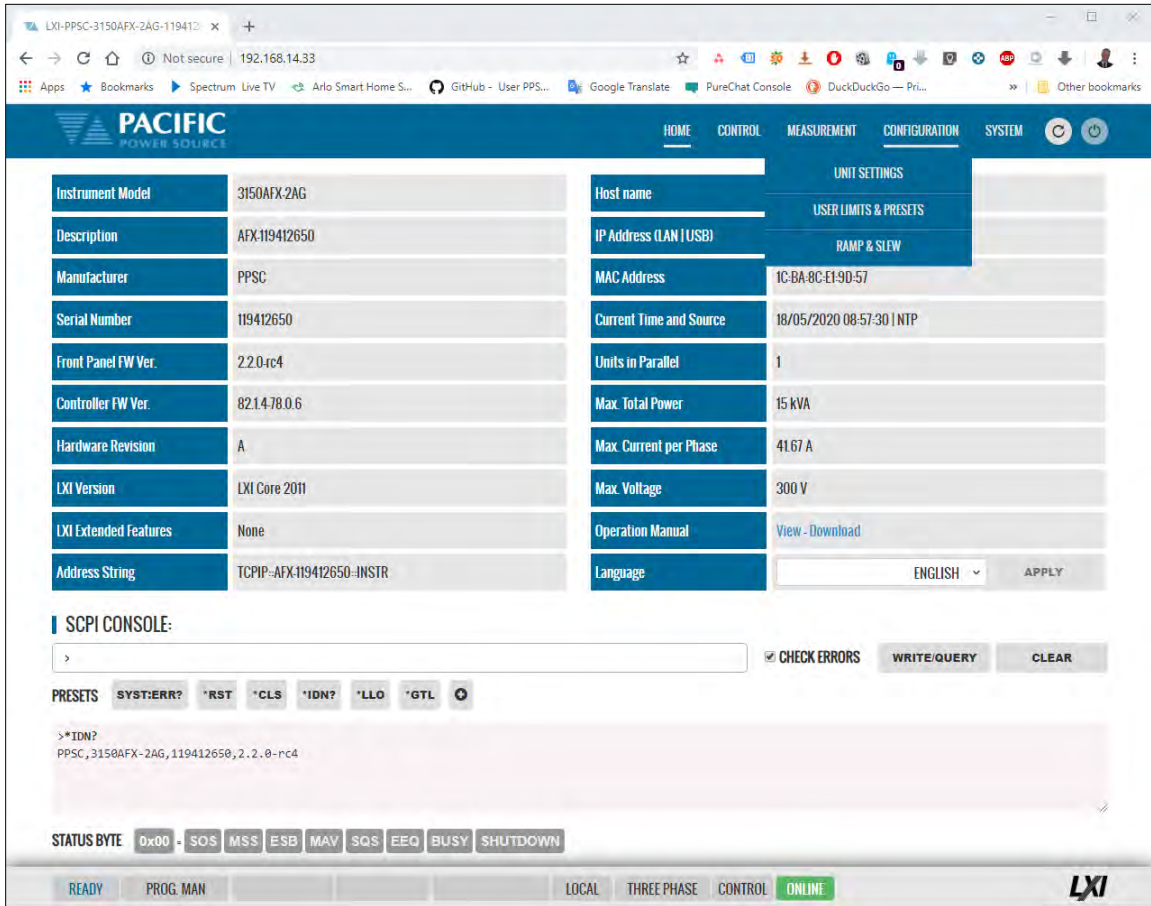

Instrument Information		Configuration Settings	
Instrument Model	3150AFX-2AG	Host name	
Description	AFX119412650	IP Address (LAN (USB))	192.168.14.33
Manufacturer	PPSC	MAC Address	1C-BA-8C-E1-9D-57
Serial Number	119412650	Current Time and Source	18/05/2020 08:57:30 NTP
Front Panel FW Ver.	2.2.0-rc4	Units in Parallel	1
Controller FW Ver.	82.14.78.0.6	Max. Total Power	15 kVA
Hardware Revision	A	Max. Current per Phase	41.67 A
LXI Version	LXI Core 2011	Max. Voltage	300 V
LXI Extended Features	None	Operation Manual	View - Download
Address String	TCPIP-AFX-119412650-INSTR	Language	ENGLISH <input type="button" value="APPLY"/>

SCPI CONSOLE:

PRESETS:

```
>*IDN?
PPSC,3150AFX-2AG,119412650,2.2.0-rc4
```

STATUS BYTE:

READY | PROG. MAN | LOCAL | THREE PHASE | CONTROL | **ONLINE** 

10.9.1 Unit Settings

Unit settings determine the mode of operation of the power source. This includes phase mode, voltage range, output mode, update phase angle and ramp time for any output value changes made.

- Output enable at power on allows the unit to power up with the output enabled.
- The Enable Current Overload setting allows short duration overloads up to 30% over the normal continuous mode current limit set point.
- Phase Rotation selection changes output phasing between positive (leading) and negative (lagging) phase rotation in three phase output mode.
- The maximum adjustment limit for continuous self-calibration mode and fault generation on saturation can be set from this screen as well.
- The right hand side of the screen contains Transient mode execution settings, Output Impedance settings and Series Connection enable / disable (Series mode is only available on AFXS models).
- Language selections are either ENGLISH or CHINESE.

These can all be set from the CONFIGURATION -> UNIT SETTINGS screen shown below.

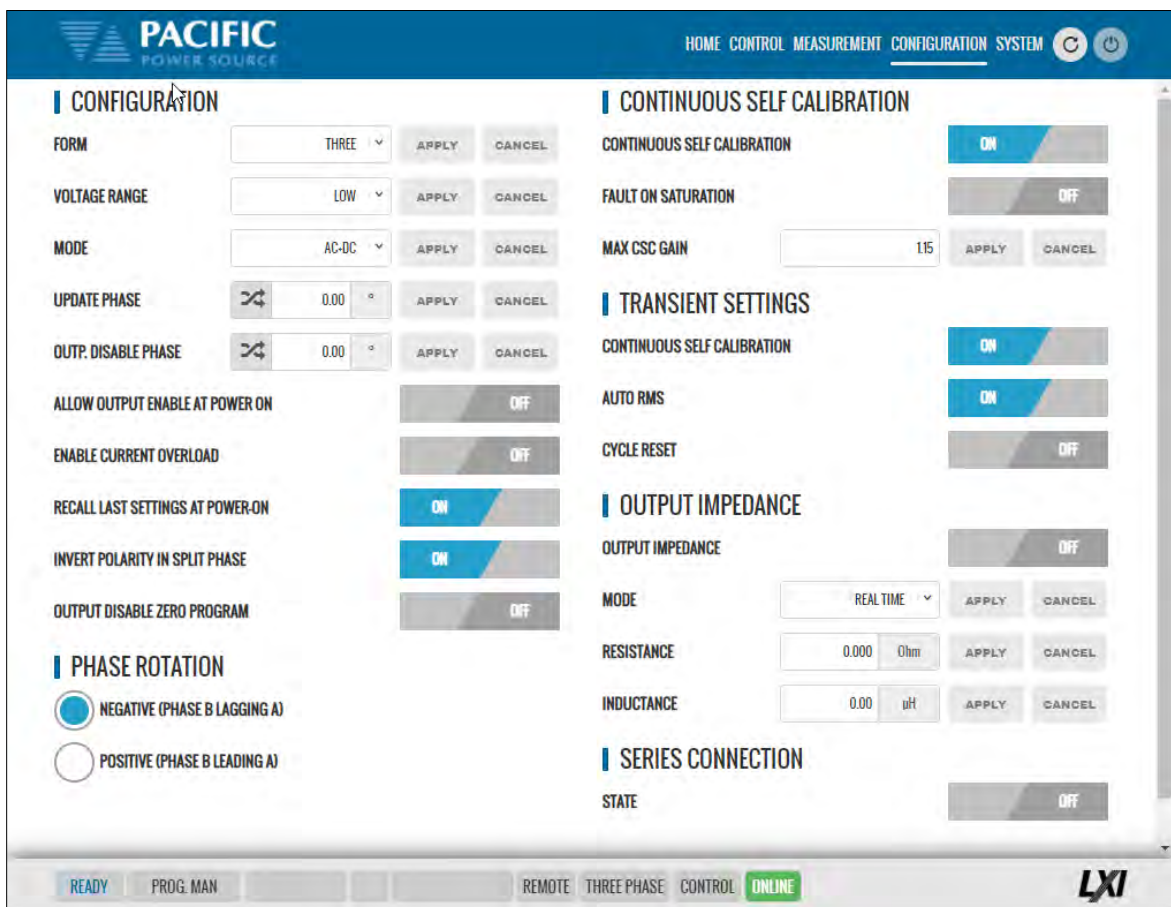

10.9.2 User Limits & Presets

User limits can be used to minimize operator error by setting upper and/or lower limits on programmable parameter ranges.

Limits can be set for Voltage AC, Voltage DC and Frequency.

Note: When changing user limits, make sure programmed parameter settings in effect are not outside the new upper and lower limits entered.

All user limits can be set from the CONFIGURATION -> USER LIMITS& PRESETS screen shown below.

Extended range for voltage and frequency may be selected as needed. Some restrictions apply when operating in extended range mode.

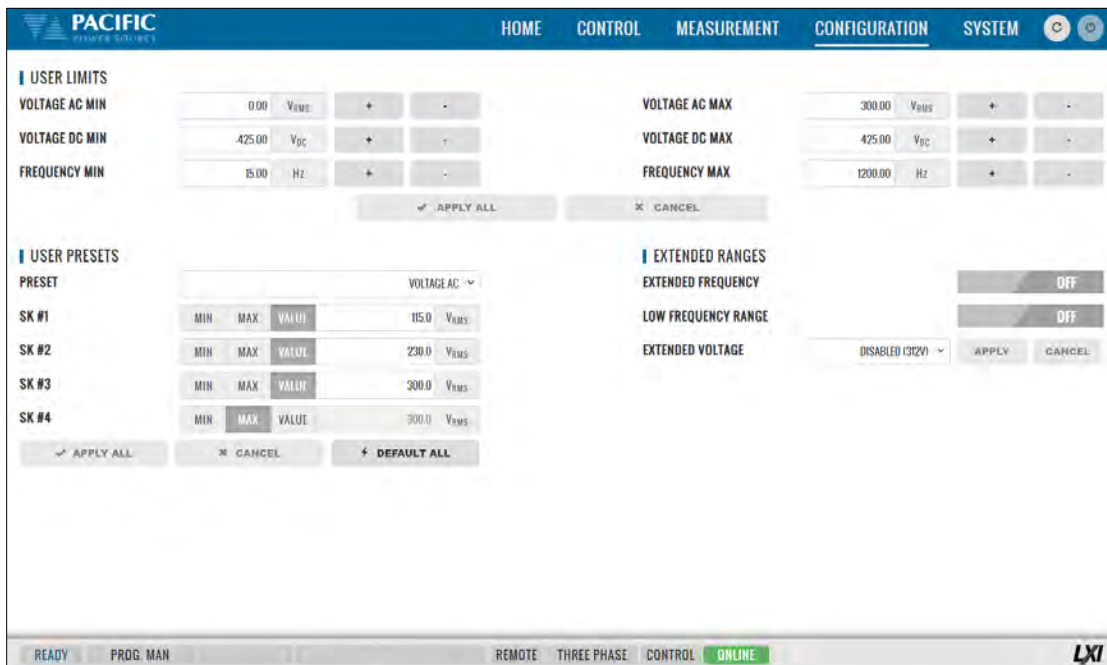

User programmable presets can be set to define the set values of the Soft keys in the program screens. This allows commonly used setting values to be selected by an operator by just pressing a single soft key. See image above for samples.

10.9.3 Ramp Time & Slew Rate

The Slew Rate screen has entries for all available programmable slew rate settings. This includes Voltage AC, Voltage DC, Frequency and Phase Angle. Note that both are mutually exclusive as they would conflict with each other. To use programmable slew rates, the RAMP TIME must be disabled.

Slew Rates can be set for Voltage AC, Voltage DC and Frequency.

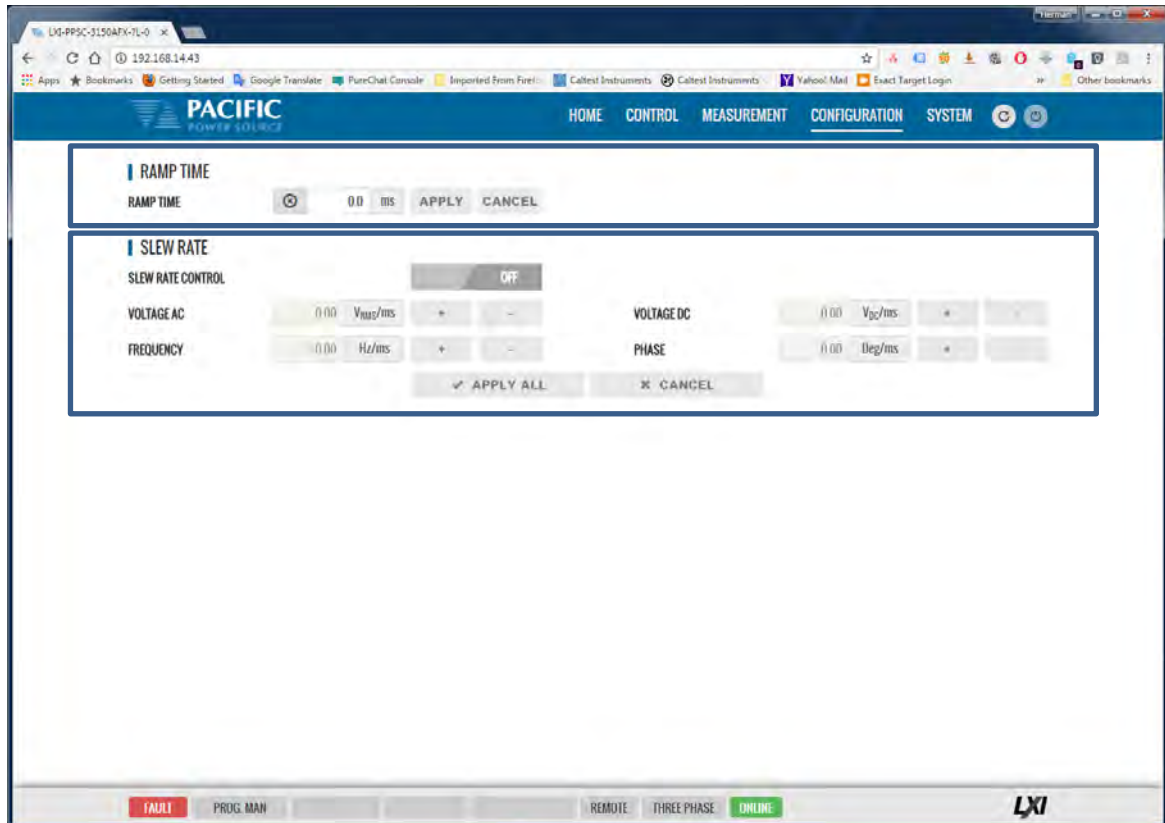

10.10 System Screens

The SYSTEM menu provides access to system level settings. System setting screens available are:

- ERROR/EVENT QUEUE
- FAULT LIST
- ERROR/EVENT LIST
- INTERFACE SETUP
- ACCESS CONTROL
- DIGITAL & ANALOG IOS (Note: on A version AFX Models only)
- UNIT INFORMATION
- PARALLEL UNITS
- MEMORY BROWSER
- CALIBRATION
- REMOTE SUPPORT
- IMPORT/EXPORT
- FIRMWARE UPDATE
- SANITIZE & REBOOT

Each is described in subsequent sections.

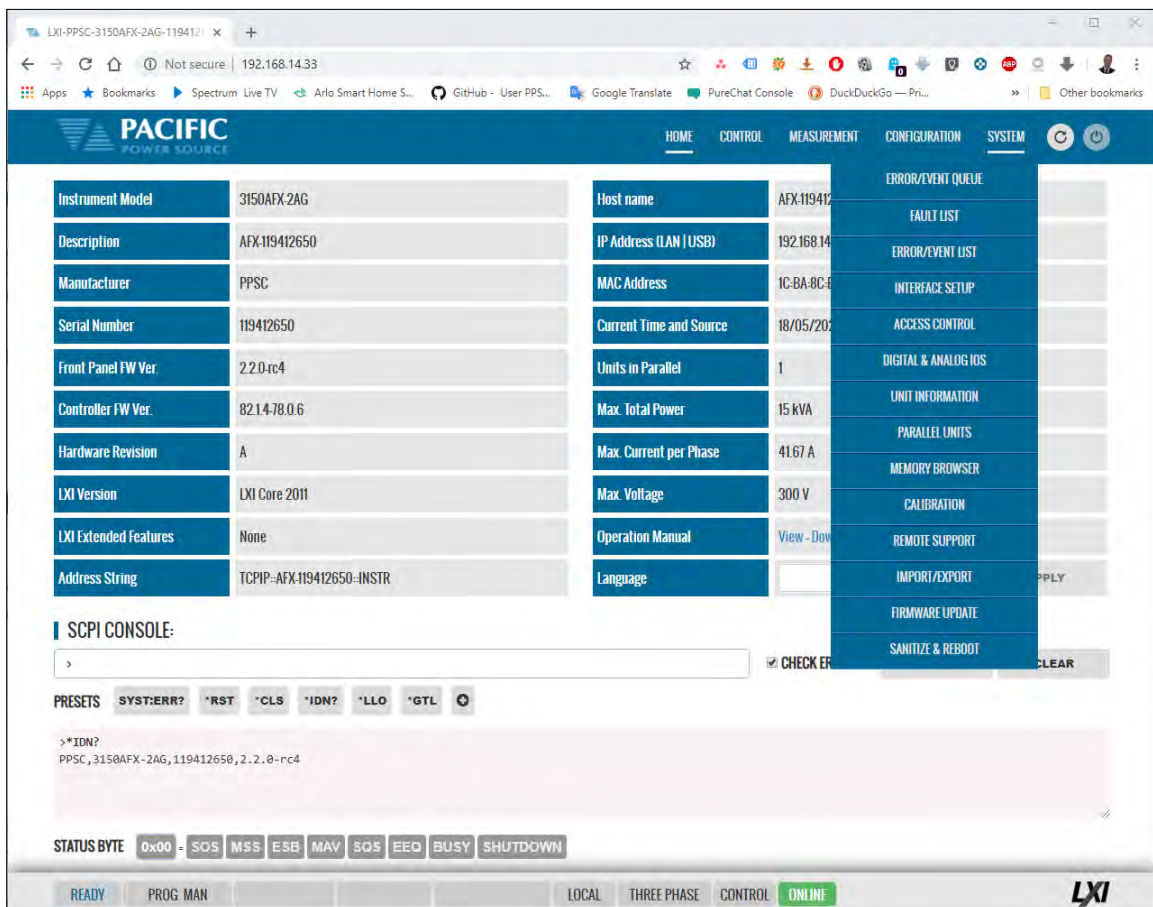

10.10.1 Error/Event Queue

The Error and Event Queue tracks internal errors or communication errors that may occur during normal user. Generally, such errors are the results of programming conflicts or setting conflicts and are no cause for concern. Other events may be normal, such as a power-on event and will be recorded in the same queue. The user can clear the queue at any time using the

CLEAR QUEUE button.

Actual hardware faults are tracked in the FAULT queue. See next section.

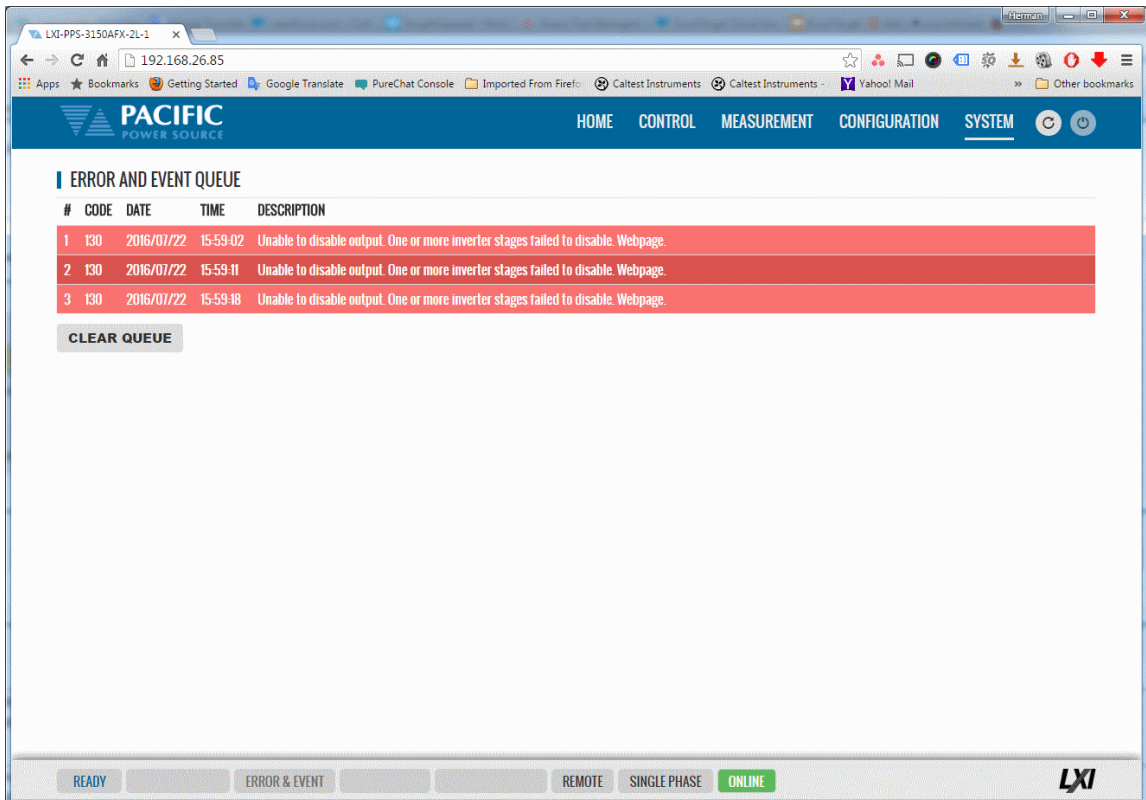

10.10.2 Fault List

The Fault List tracks hardware faults that may occur in the power conversion stages. This information may be useful for PPS engineering staff.

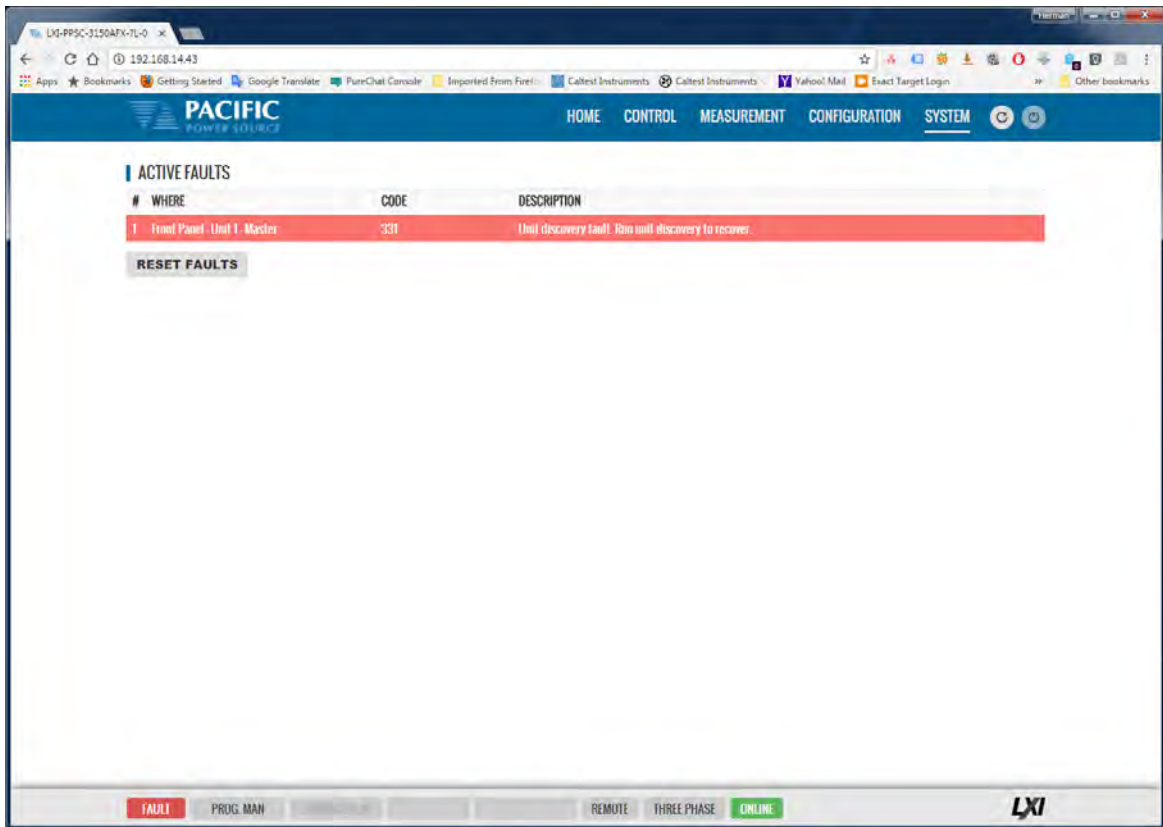

10.10.3 Error/Event List

The Error Event list provides a complete listing of all possible error and event messages. The description may include possible troubleshooting hints to resolve any error conditions.

Errors are listed in numerical order.

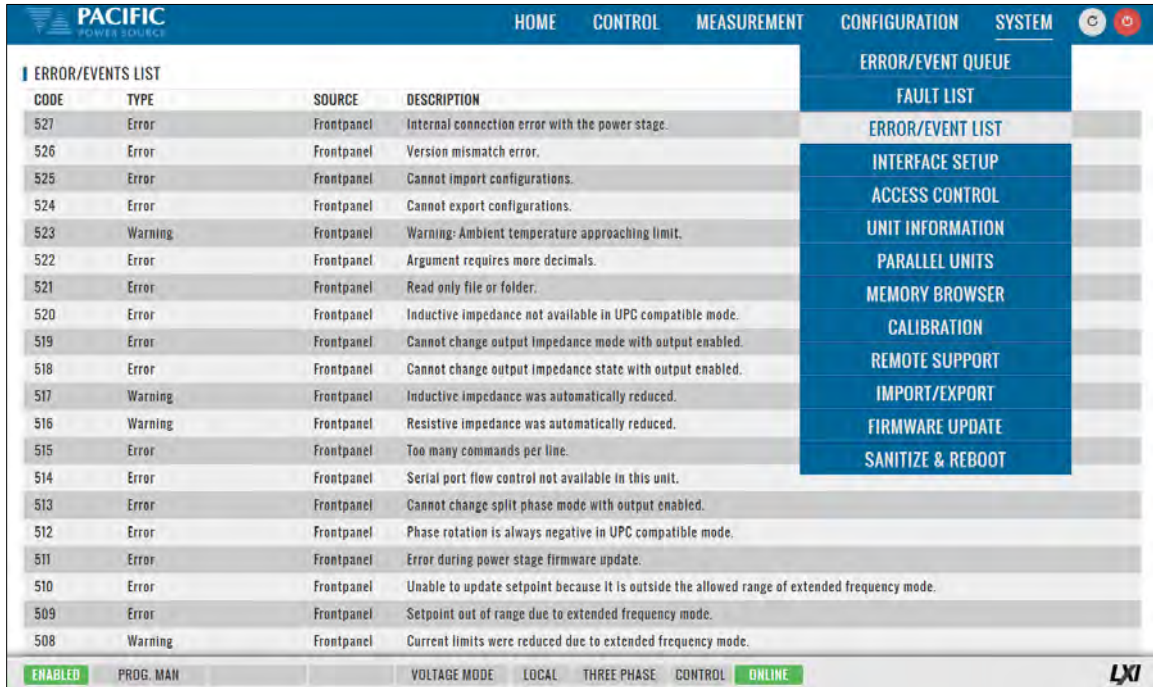

CODE	TYPE	SOURCE	DESCRIPTION
527	Error	Frontpanel	Internal connection error with the power stage.
526	Error	Frontpanel	Version mismatch error.
525	Error	Frontpanel	Cannot import configurations.
524	Error	Frontpanel	Cannot export configurations.
523	Warning	Frontpanel	Warning: Ambient temperature approaching limit.
522	Error	Frontpanel	Argument requires more decimals.
521	Error	Frontpanel	Read only file or folder.
520	Error	Frontpanel	Inductive impedance not available in UPC compatible mode.
519	Error	Frontpanel	Cannot change output impedance mode with output enabled.
518	Error	Frontpanel	Cannot change output impedance state with output enabled.
517	Warning	Frontpanel	Inductive impedance was automatically reduced.
516	Warning	Frontpanel	Resistive impedance was automatically reduced.
515	Error	Frontpanel	Too many commands per line.
514	Error	Frontpanel	Serial port flow control not available in this unit.
513	Error	Frontpanel	Cannot change split phase mode with output enabled.
512	Error	Frontpanel	Phase rotation is always negative in UPC compatible mode.
511	Error	Frontpanel	Error during power stage firmware update.
510	Error	Frontpanel	Unable to update setpoint because it is outside the allowed range of extended frequency mode.
509	Error	Frontpanel	Setpoint out of range due to extended frequency mode.
508	Warning	Frontpanel	Current limits were reduced due to extended frequency mode.

10.10.4 Interface Setup

The Interface setup screen allows enabling or disabling of several available interfaces and operating modes. The interfaces are arranged by type:

- LAN
- USB
- RS232 Serial
- GPIB (Note: on A version AFX Models only)

Interfaces that are not used can be turned off to avoid conflicts caused by multiple active interfaces at the user's discretion.

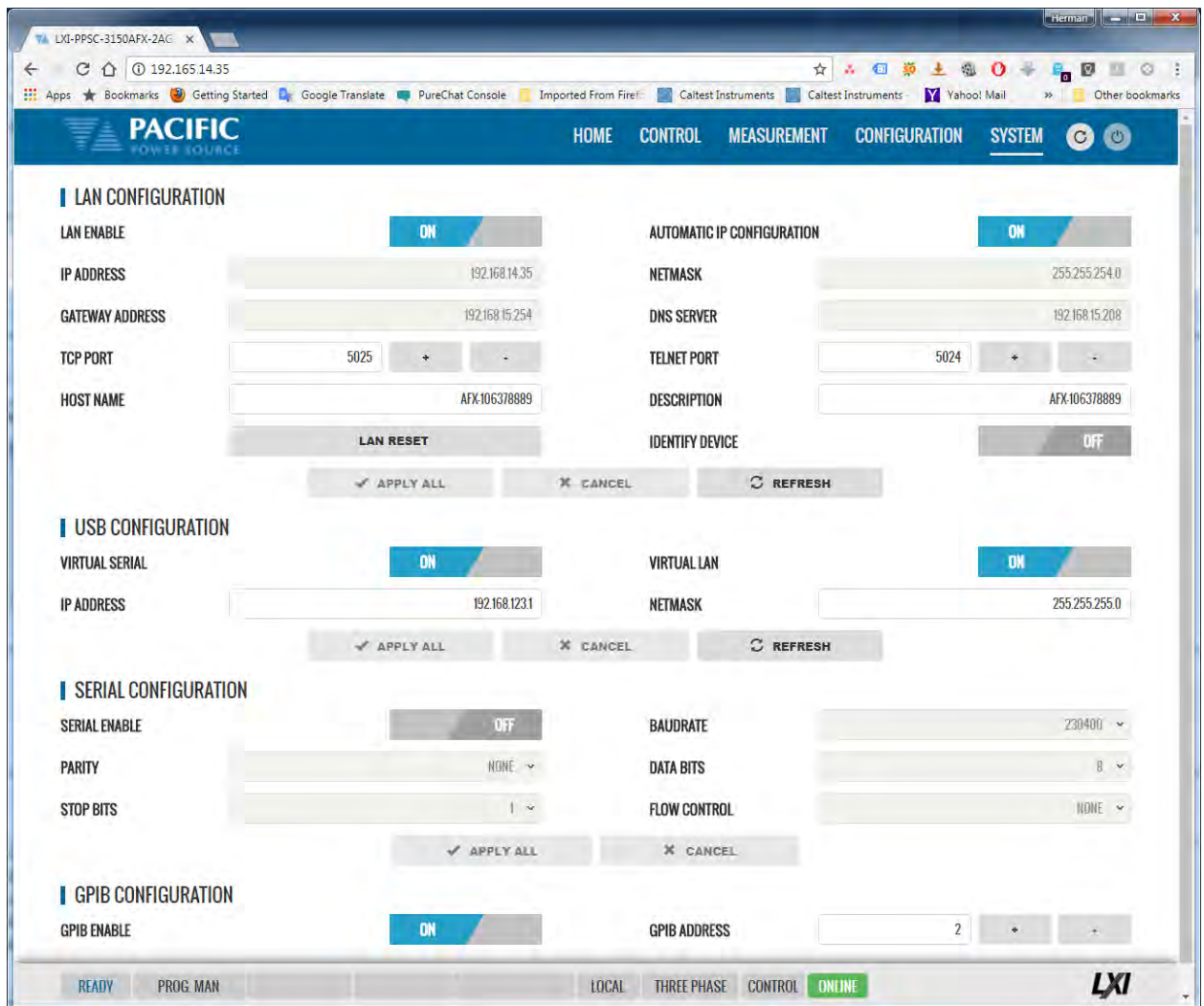

10.10.5 Access Control

The access control screen allows restricting access to the power source over the LAN interface. This is an important requirement for power sources connected to a company wide Ethernet network. Without access restrictions, persons not present where the power source is located could inadvertently cause a dangerous condition by either enabling the OUTPUT or changing programmed settings.

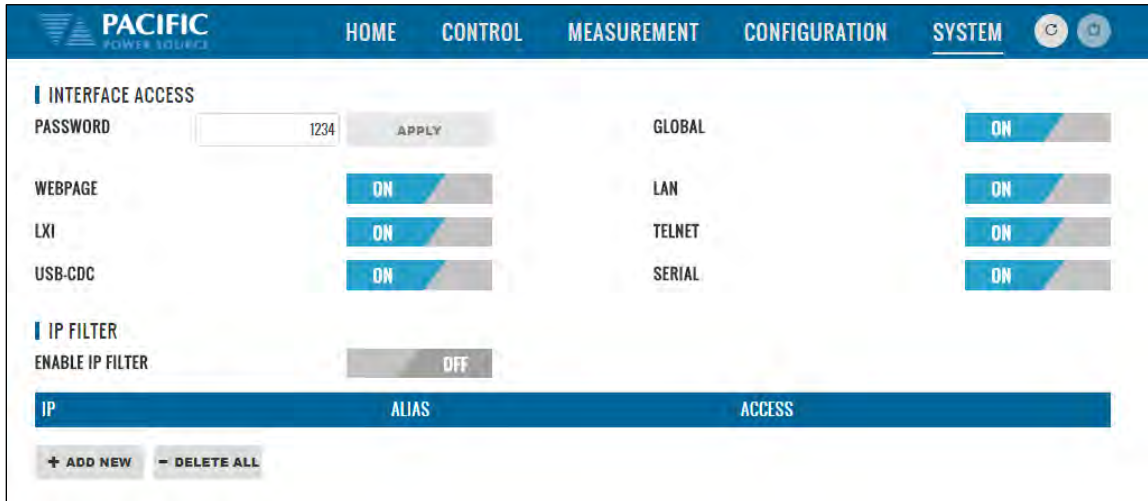

Access control can limit access from specific IP addresses only and requires someone physically present where the power source is to grant access to anyone else.

For more details, refer to section 10.3, “Access Control” on page 430 of this manual.



10.10.6 Digital & Analog IO's

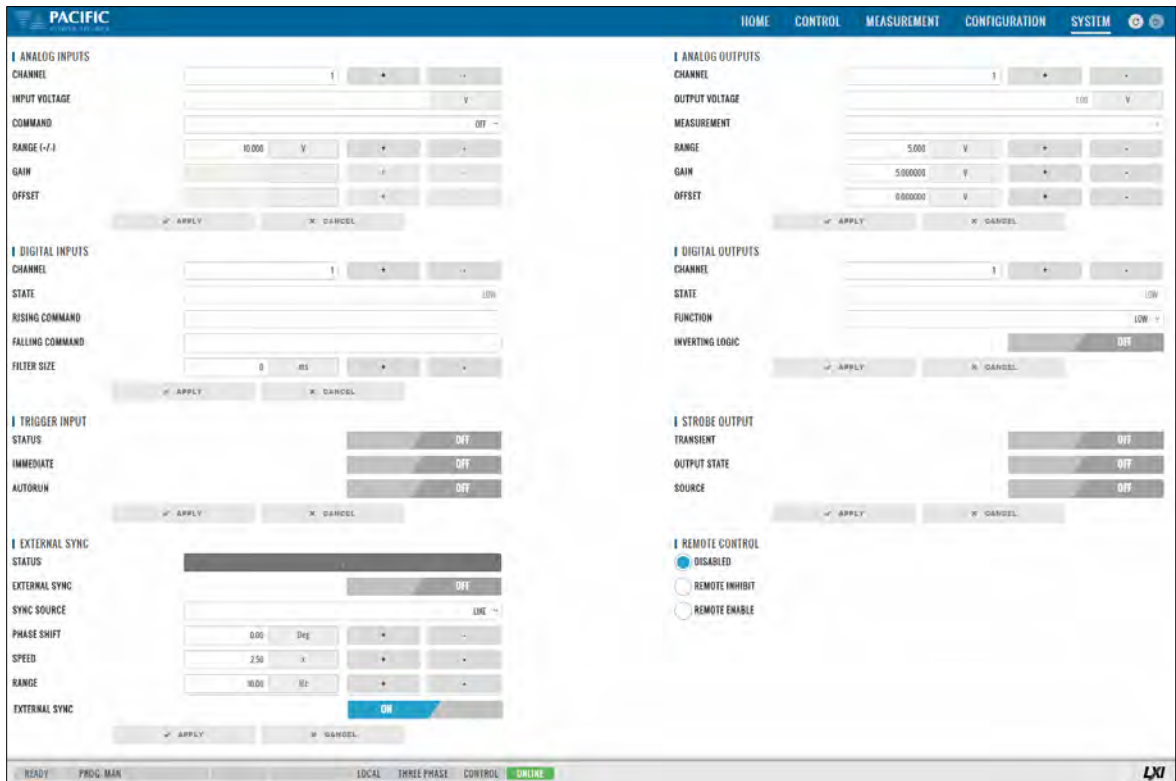



The Digital and Analog IO screen allows configuration of the available Auxiliary I/O functions. Note that this feature is not available on AFX-2L and AFX-4L models.

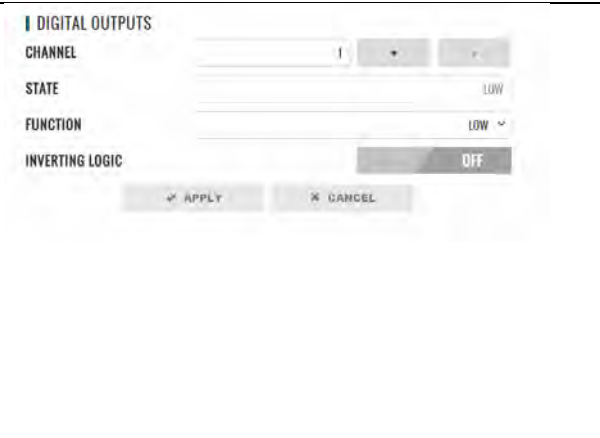

10.10.6.1 Function Groups

There are eight groups of functions that are available to be configured with the selectable settings listed in the table below.

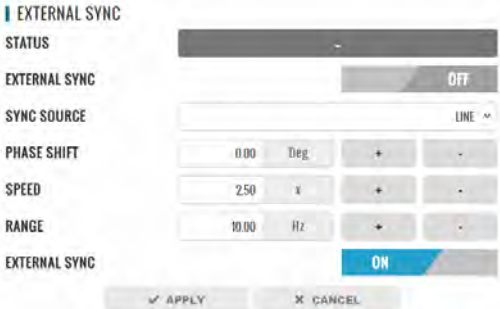
Grouping	Controls
<p>Analog Inputs:</p> <p>CHANNEL [1 2 3 4]</p> <p>INPUT VOLTAGE Displays read back voltage</p> <p>COMMAND Select command from dropdown list or OFF for none</p> <p>RANGE 0.0000 – 10.000 V</p> <p>GAIN Gain</p> <p>OFFSET Offset value</p>	
<p>Analog Outputs:</p> <p>CHANNEL [1 2 3 4]</p> <p>OUTPUT VOLTAGE Output setting</p> <p>MEASUREMENT Select measurement to be assigned to output</p> <p>RANGE 0.0000 – 5.000 V</p> <p>GAIN Gain 0.000 - 1000</p> <p>OFFSET Offset value – 1000 ~+1000</p>	
<p>Digital Inputs:</p> <p>CHANNEL [1 2 3]</p> <p>STATE Displays input state</p> <p>RISING CMD Set command string to execute on rising edge</p> <p>FALLING CMD Set command string to execute on falling edge</p> <p>FILTER SIZE 0 – 10,000,000 msec</p>	
<p>Digital Outputs:</p> <p>CHANNEL [1 2 3 4]</p> <p>STATE Displays current state</p> <p>FUNCTION Assigns state to selected channel. Available states are: FAULT FORM HIGH LOW OUTPUT STATE PROGRAM REMOTE TRANSIENT</p> <p>INV. LOGIC [ON OFF] Reverses polarity</p>	

Grouping	Controls
<p>Trigger Input:</p> <p>STATUS [ON OFF] Enabled or disabled</p> <p>IMMEDIATE [ON OFF] Ignore phase update setting if ON</p> <p>AUTORUN [ON OFF] No RUN command required if ON</p>	 <p>The screenshot shows the 'TRIGGER INPUT' control panel. It includes three toggle switches: 'STATUS' (OFF), 'IMMEDIATE' (ON), and 'AUTORUN' (OFF). At the bottom, there are 'APPLY' and 'CANCEL' buttons.</p>
<p>—Strobe Output:</p> <p>TRANSIENT ON = Strobe output on transient start</p> <p>OUTPUT STATE ON = Strobe output on relay close</p> <p>SOURCE ON = Strobe output on any program parameter change</p>	 <p>The screenshot shows the 'STROBE OUTPUT' control panel. It includes three toggle switches: 'TRANSIENT' (OFF), 'OUTPUT STATE' (OFF), and 'SOURCE' (OFF). At the bottom, there are 'APPLY' and 'CANCEL' buttons.</p>
<p>External Sync:</p> <p>STATUS Display SYNC Status</p> <p>EXTERNAL SYNC [ON OFF]</p> <p>SYNC SOURCE Select Sync source</p> <p>Available sources are: - External sync input on I/O connector - LINE (AC input to power source)</p> <p>PHASE SHIFT Offset Phase A angle</p> <p>SPEED 1.00 ~ 10.00</p> <p>RANGE 0.10 ~ 500 Hz</p> <p>EXTERNAL SYNC [ON OFF]</p>	 <p>The screenshot shows the 'EXTERNAL SYNC' control panel. It includes a 'STATUS' field, an 'EXTERNAL SYNC' toggle switch (OFF), a 'SYNC SOURCE' dropdown menu (set to 'LINE'), and three numeric input fields: 'PHASE SHIFT' (0.00 Deg), 'SPEED' (2.50), and 'RANGE' (10.00 Hz). Each input field has '+' and '-' buttons. At the bottom, there are 'APPLY' and 'CANCEL' buttons.</p>
<p>Remote Controls:</p> <p>DISABLED No remote output control</p> <p>REMOTE INHIBIT Contact closure needed to close output relay</p> <p>REMOTE ENABLE Contact closure or front panel can control output relay</p>	 <p>The screenshot shows the 'REMOTE CONTROL' panel. It features three radio button options: 'DISABLED' (selected), 'REMOTE INHIBIT', and 'REMOTE ENABLE'.</p>

10.10.6.2 On-line Analog and Digital I/O help screens.

To aid in configuring and using the many I/O capabilities of the power source, a series of on-line help screens containing formulas and graphs for digital and analog I/Os settings are provided.

Some screens are shown below for reference.

DIGITAL INPUTS

The FILTER SIZE parameter is useful for noise immunity.
If the pulse width is lower than the filter size it is ignored and the command is not executed.

CLOSE

ANALOG OUTPUTS

The output voltage will be automatically set with a VALUE given by this formula:

$$VALUE = \frac{MEASUREMENT - OFFSET + CO * GAIN}{GAIN * CG} * RANGE$$

- CG is the calibration gain. By default, it is 1 and it can be set with SYSTEM:AIO-OUTput#-CALibration-GAIN
- CO is the calibration offset. By default, it is 0 and it can be set with SYSTEM:AIO-OUTput#-CALibration-OFFset

The GAIN and OFFSET change when the measurement is changed while the CO and CG do not change.

With CO equal to 0 and CG equal to 1, the formula is:

$$VALUE = \frac{MEASUREMENT - OFFSET}{GAIN} * RANGE$$

CLOSE

ANALOG INPUTS

The selected COMMAND will be automatically set with a VALUE given by this formula:

$$VALUE = \left(\frac{INPUT VOLTAGE}{RANGE} * CG - CO \right) * GAIN + OFFSET$$

- CG is the calibration gain. By default, it is 1 and it can be set with SYSTEM:AIO-INput#-CALibration-GAIN
- CO is the calibration offset. By default, it is 0 and it can be set with SYSTEM:AIO-INput#-CALibration-OFFset

The GAIN and OFFSET change when the COMMAND is changed while the CO and CG do not change.

With CO equal to 0 and CG equal to 1, the formula is:

$$VALUE = \left(\frac{INPUT VOLTAGE}{RANGE} \right) * GAIN + OFFSET$$

CLOSE

10.10.7 Remote Interface (Virtual Front Panel)



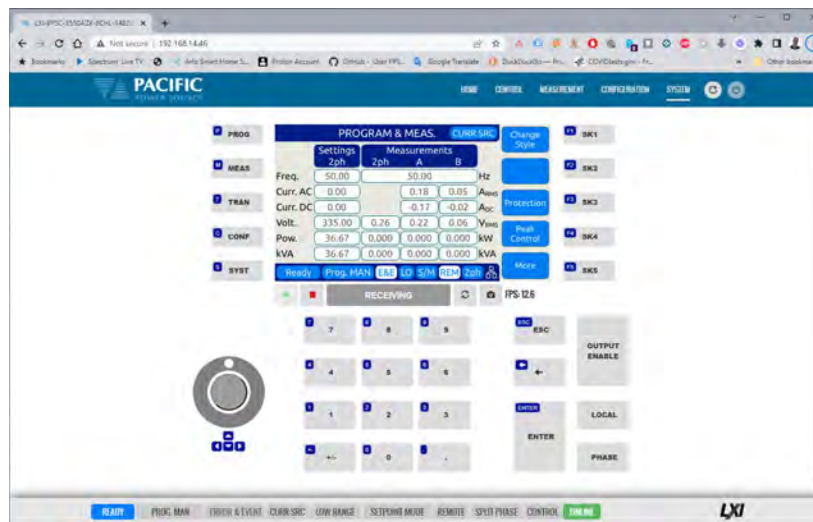

The Remote Interface browser screen provides a virtual front panel that allows controlling the power source from a remote location using a PC, tablet or smart phone. The screen layout is a function of the web hosting device screen width. If wide enough, the layout will match that of the actual front panel of the power source. If too narrow for a landscape view, the front panel will be divided between the LCD screen, function and soft keys on top and the know plug decimal keypad and other control beneath it. Both layouts are shown below.



The operation of this Virtual Front panel is identical of that of the physical front panel so refer to Section 6, “Front Panel Operation” on page 111 for user information. The operation of this Virtual Front panel is identical of that of the physical front panel so refer to Section 6, “Front Panel Operation” on page 111 for user information. The controls located directly below the virtual LCD screen may be used when the internet connection used is slow or there is too much latency.



Available controls are:

-  Enable continuous update mode. In this mode, the status bar will show .
-  Stop continuous updated mode. The connection status will show .

RECEIVING Status Bar shows state of connection to the power source. Clicking on it will toggle connections status between **DISCONNECTED** and **CONNECTED**.

 Refresh button may be used when continuous updates are off to refresh the display

 Click to download a .png image of the virtual LCD display.

The status field to the right of the control buttons display the measurement frame update rate. In the example shown here the frame rate is 14.6 frames per second.

10.10.8 Unit Information

The Unit Information screen contains some of the same information as is found on the HOME screen but it can be used to query this information from one or more auxiliary unit as well in a parallel system. The HOME screen will only display information for the Master unit of a parallel configured system. Use the SELECTED UNIT control to select units downstream from the master (1).

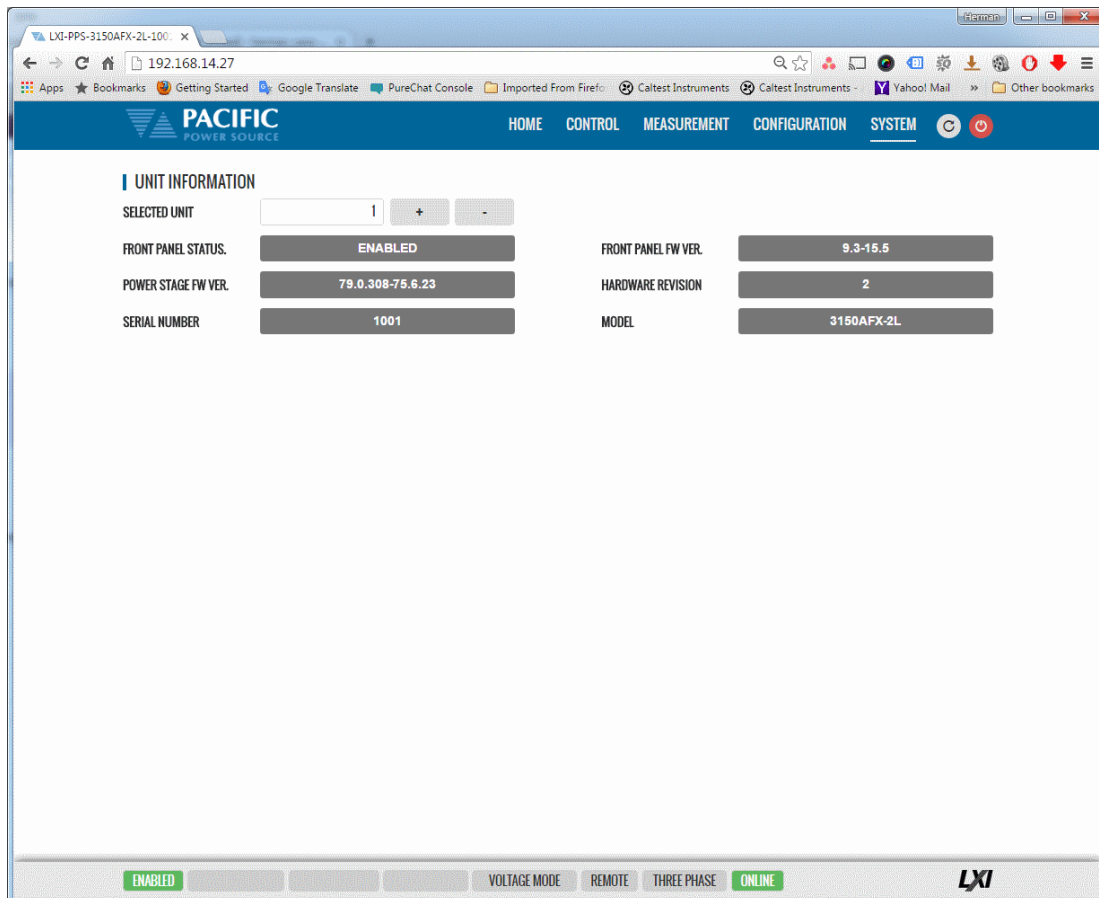

10.10.9 Connected Units

The Connected¹⁰ Units screen displays the number of powered on units connected in either a Parallel or Series system. It also allows the expected number of units to be set so the master can determine if all connected units are indeed turned on before starting operation.

The MANUAL DISCOVERY can be run to refresh the system configuration if a unit has been turned on or off without power cycling the master.

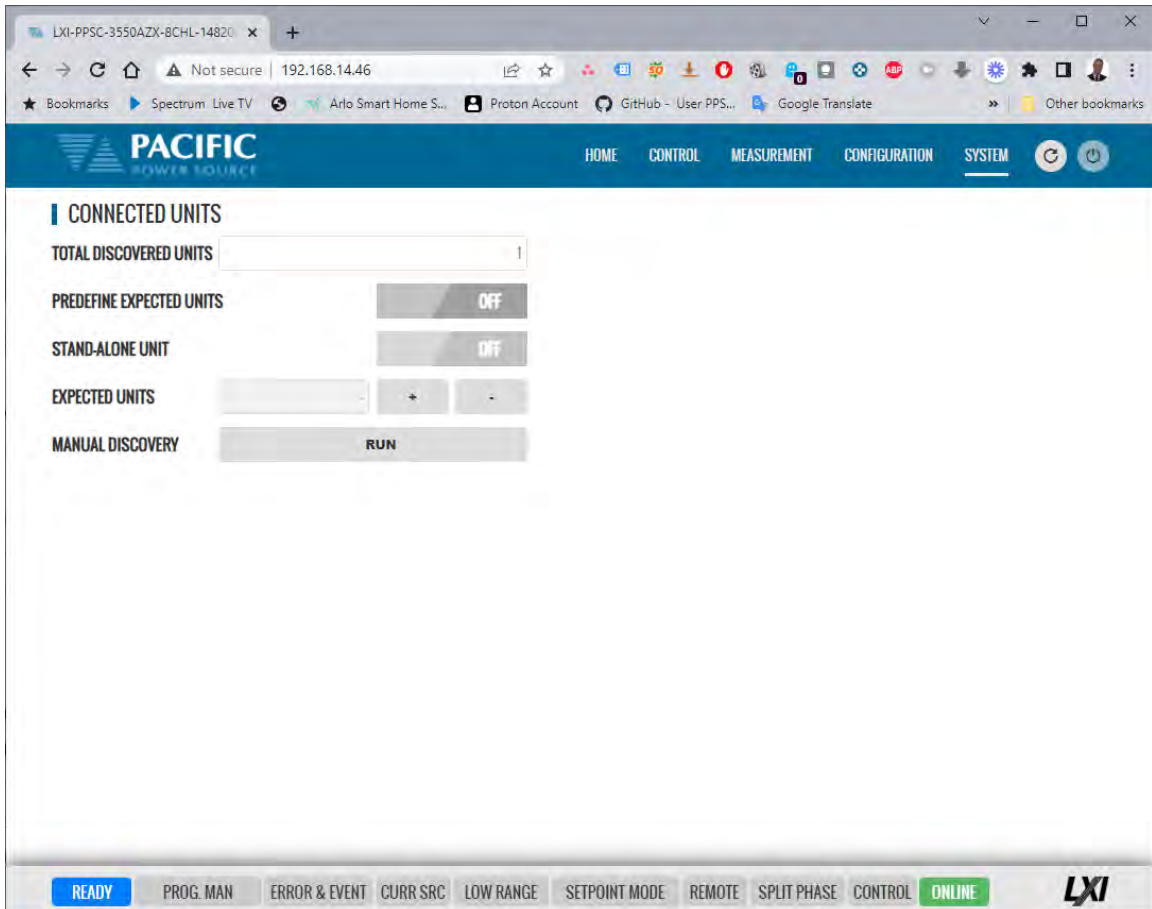

¹⁰ On Models with older firmware, this menu entry was shown as "Parallel Units".

10.10.10 Memory Browser

The Memory Browser screen shows available memory devices connected to the instrument including internal memory and available directories and files. All data and setup files are in XML format. Waveform files are stored in CSV format. Screen captures are stored in PNG image format.

Available MEMORY DRIVES are INTERNAL, RAM and any USB or SD-Card memory devices that are mounted. Files can be copied or move from other drives by using drag & drop or by selecting them. Files can also be uploading using a file selection window dialog.

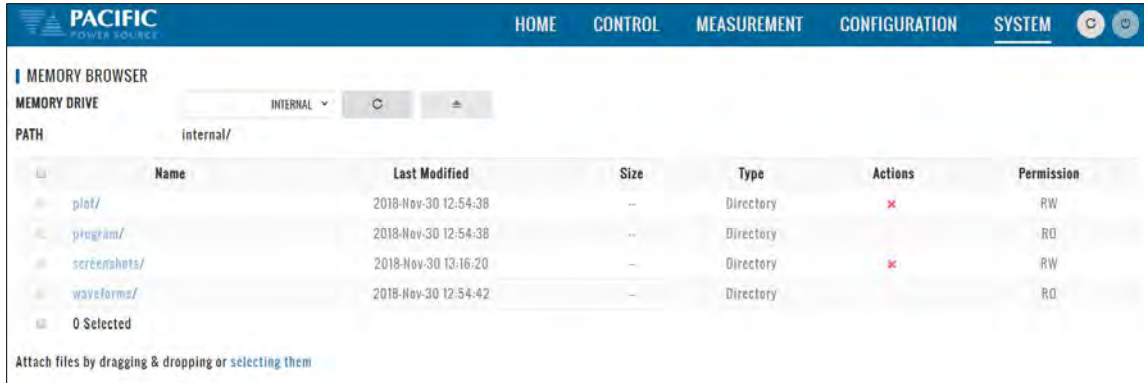

Useful directories for the user are:

DIRECTOR	FILES IN THIS DIRECTORY
plot/	Data logger plots in csv file format with date and time stamp
program/	Power source program settings
screenshots/	Screen capture image files in .png format with date and time stamp. To capture any LCD display, press the LOCAL key and the number 1 key on the decimal keypad at the same time.
waveforms/	User waveform data points in csv file format.

10.10.10.1 Screenshots

Screenshots of the LDC display saved by pressing the LOCAL + 1 key simultaneously are saved in the screenshots subdirectory. The controls in the Actions column allow the user to:

- Delete
- Download
- Preview

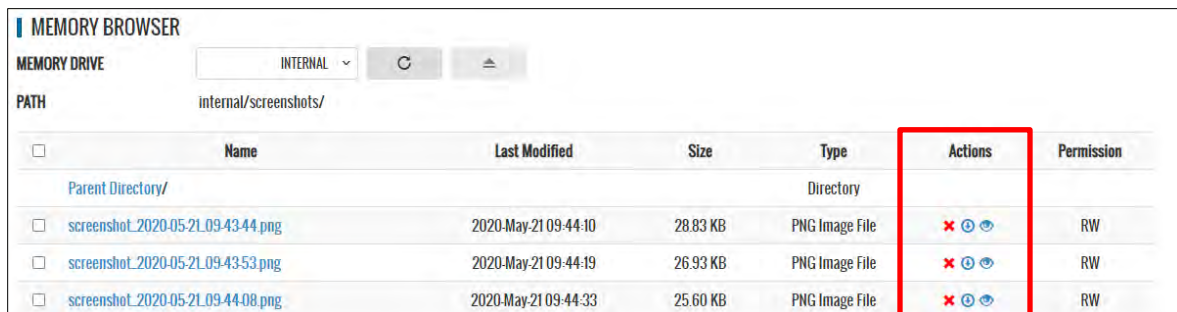

10.10.11 Calibration

The Calibration screen shows all user accessible calibration coefficients. It also allows for user calibration of voltage and current to be performed. The Web Browser user interface is specific but the procedures and equipment are the same as calibration from the front panel. Refer to Section 11.4, “Calibration Procedures” for details.

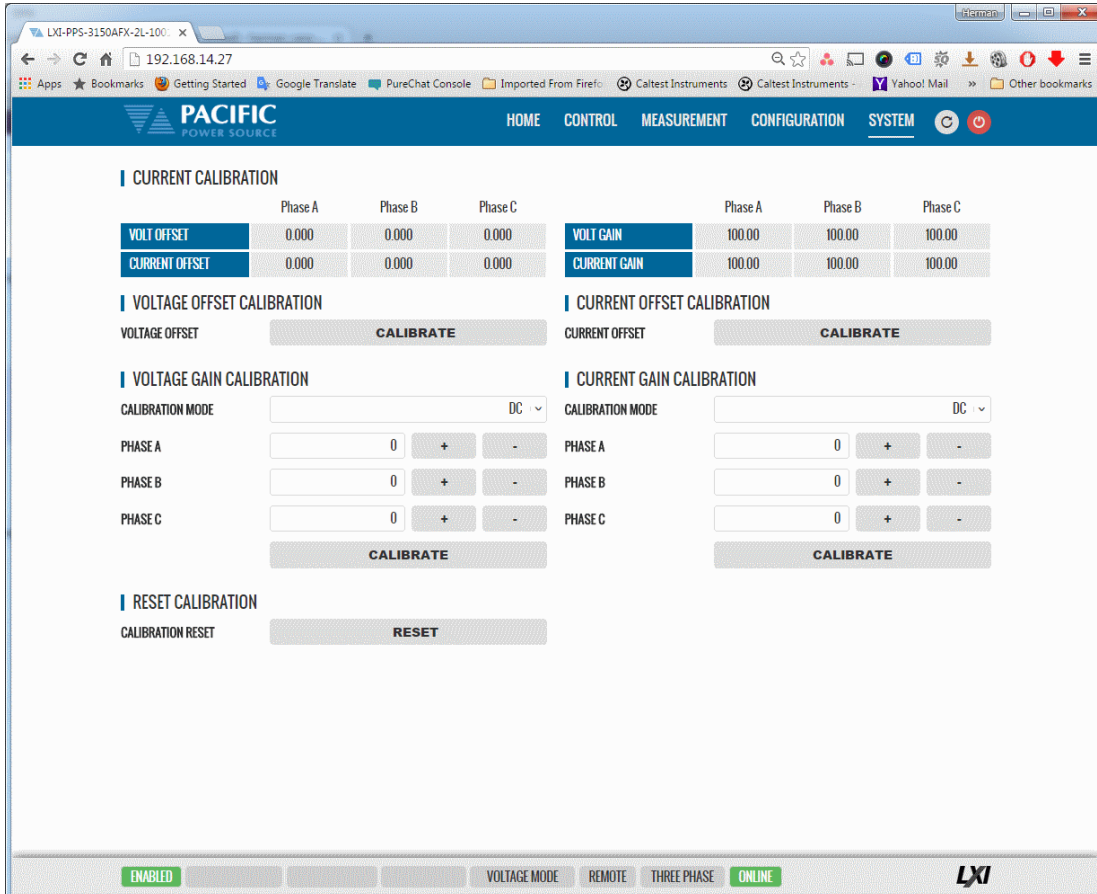

10.10.12 Remote Support

The Remote Control screen allows Pacific Power’s technical support staff to access the unit remotely if granted permission. Internet access is required for this feature.

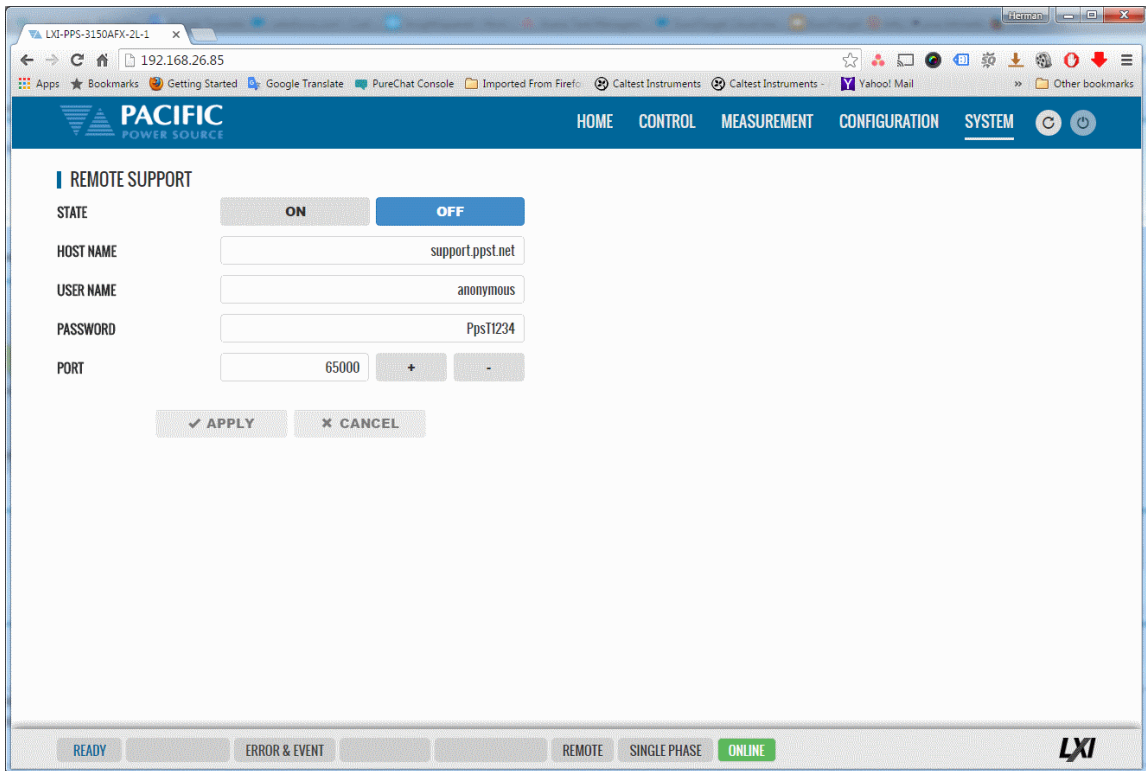

10.10.13 Import / Export



A compressed file containing complete system configuration data for the power source can be exported to a file and imported back into the unit as needed. Files are .7z compressed to maximize storage space. Use the Export button on the right to export (save) current configuration data. Use the Browse button to select and import (load) a previously saved configuration file.



10.10.14 Firmware Update

The Firmware update screen can be used to install new firmware for a file. New firmware may be distributed by email or from Pacific’s FTP site. Note that the OUTPUT of the unit must be OFF to perform a firmware update.

If you received a firmware image file (.img extension):

- Use the  button to select it from the drive location you saved it to.
- Then use the  button to upload new firmware to the power source.

To install new firmware from the Pacific Power FTP server:

- Click the  button.

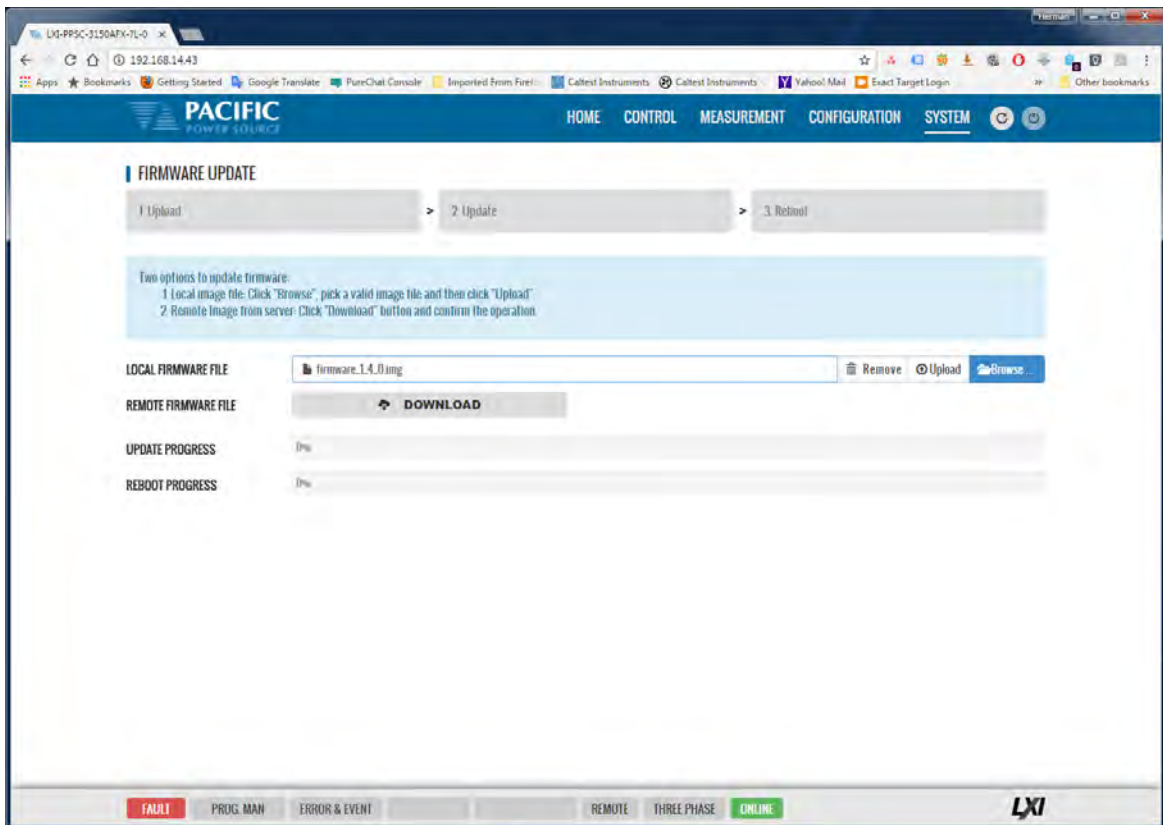

10.10.15 Sanitize and Reboot

This screen allows the unit to be cleared of all user settings. This applies to waveforms, settings, transients etc. The unit will be reset to factory default conditions.

The Reboot allows the power source to be rebooted (reset) without cycling AC input power.

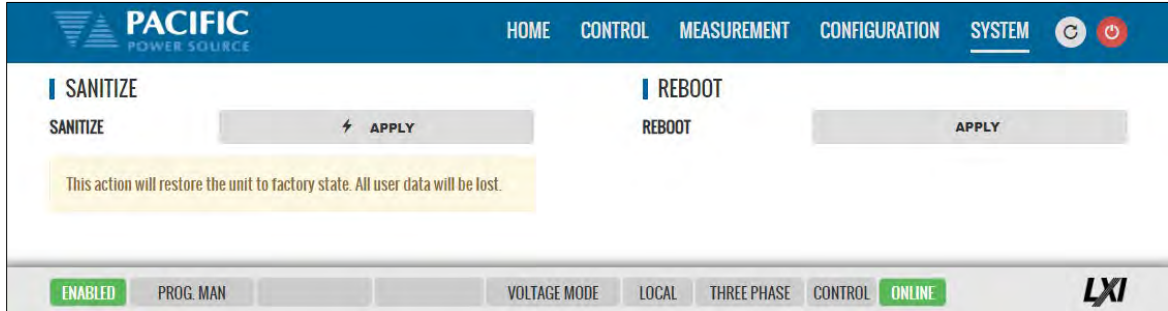

10.11 Additional Functions

Additional function may be added over time through firmware updates that may not be covered by this user manual revision. If so, check the Pacific Power website for update manual versions. (www.pacificpower.com).

10.11.1 Sharing Options – FTP & SAMBA

Units with firmware revision 2.1.0 or higher support a network based sharing feature. Two protocols. These can be enabled from the Sharing Options screen. For more details, refer to Section 6.8.5.9, “REMOTE SHARING” on page 186.



11 Calibration

11.1 Calibration Interval

All units are shipped new from the factory with NIST traceable calibration. It is recommended to perform an annual calibration check to ensure performance to specifications. Under normal circumstances, no adjustment will be needed but can be made as part of the user calibration coefficients.

11.2 Closed Case User Calibration

This section covers routine calibration that can be performed by the user. User calibration does not affect the factory set calibration coefficients that were determined and set at the time of shipment to ensure compliance with published specifications. Rather, user calibration can be used to obtain enhanced performance at typical operating conditions by adjusting these user coefficients at these conditions. For example, if the unit is used primary for testing 400Hz, three phase 115V L-N three phase operation, calibrating the user coefficients to these operating conditions against an external precision reference can provide enhanced performance versus published specifications (See Section 4, “Technical Specifications”).

Since user calibration does not affect factory calibration settings, resetting all user calibration coefficients does not invalidate the units specified performance and it can be used with all user coefficients reset as needed.

Note: There are no analog adjustment pots in this instrument and all calibration can be performed from the front panel or over one of the digital control interfaces.

11.3 Equipment Required

The following list of equipment or equivalent is required to perform routine annual calibration of the instrument. Current sensor options are determined by need for AC, DC or both.

Item	Make	Model	Notes
1	Keysight	34465A	6 ½ Digit DMM or equivalent
2	Current Transformer (AC Only)	Pearson	Model 110, 65 Arms Max. 5000Apk Max. 0.1V/A +1/-0%, Rout = 50 Ohms http://www.pearsonelectronics.com/products/current-monitors
3	Current Sensor (AC and DC)	LEM	IT 200-S ULTRASTAB, 200 A, ± 0.0086% Accuracy, 50 kHz BW or equivalent. https://www.lem.com/en/product-list/it-200s-ultrastab Requires precision burden resistor for direct DMM measurements, i.e. Reidon, P/N SM10-100RX, 0.01% 100 Ohm, 0.3W, qty 2 or 3 in parallel for 50 Ohm or 33.3 Ohm burden https://www.digikey.com/product-detail/en/riedon/SM10-100RX/696-1568-ND/4832952
4	Current Shunt (DC)	Ohm-Labs	CS-200, Shunt, 1 mOhm, 0.02% Accuracy @ DC to 50/60 Hz or equivalent http://www.ohm-labs.com

Table 11-1: Required Calibration Equipment

11.4 Calibration Procedures

Calibration of output and measurements is performed by a single procedure so there is no need to calibrate each separately. Calibration involves voltage and current full scale and offset on each phase. For three-phase mode, this means there are twelve calibration points, for single-phase mode, there are four.

The calibration can be performed manually using the Calibration menu (refer to Section 6.8.9 for the location of the Calibration menu) or through the build-in web server using the web browser interface. Refer to Section 10.10.11, “Calibration” for access to the Web based calibration screens.

11.4.1 Voltage Calibration - Offset

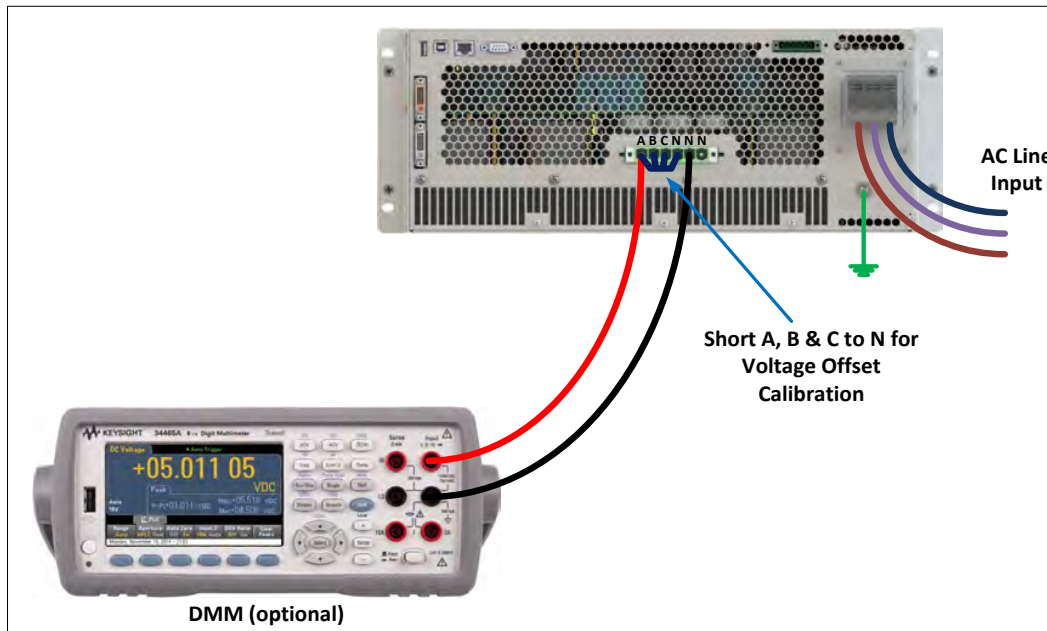

Table 11-2: Setup for Voltage Offset Calibration

The procedure to calibrate voltage offset is:



1. Select the Calibration entry from the “System” menu
2. Press the “Calibrate” soft key to enter calibration mode

3. Short all phases to neutral using a shorting jumper
4. You can connect the DMM to the output of phase A as shown in the figure above but it is not required for this calibration step.
5. **IMPORTANT:** Program both AC and DC voltage (depending on voltage mode) to all **zero volts** to avoid any current from flowing into the shorted outputs. Use PROGRAM screen to make sure both AC and DC settings are zero.
6. Enable the Output with the output shored.
7. Press "Cal V. offset" soft key
8. Wait for the V offset coefficients for all phases to be calculated and displayed
9. Remove the shorting jumper when done

Note: The Mode, Voltage and Current edit boxes do not affect this function.

11.4.2 Current Calibration - Offset

The procedure to calibrate current offset is:

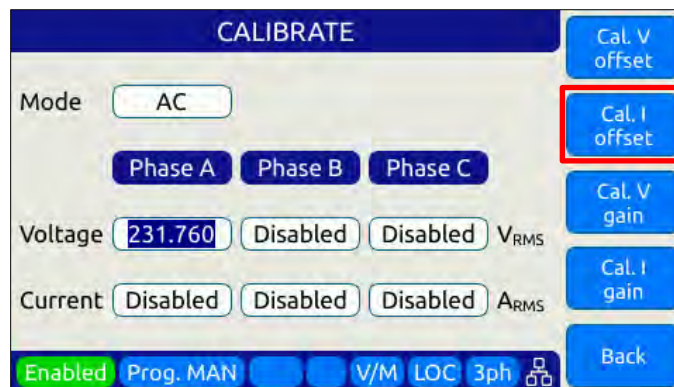

1. Select the Calibration entry from the “**System**” menu
2. Press the “Calibrate” soft key to enter calibration mode
3. Do not connect any load to the output
4. Enable the Output with no load connected
5. Press "Cal I. offset" soft key
6. Wait for the I offset coefficients for all phases to be calculated and displayed

Note: The Mode, Voltage and Current edit boxes do not affect this function.

11.4.3 Voltage Calibration - Gain

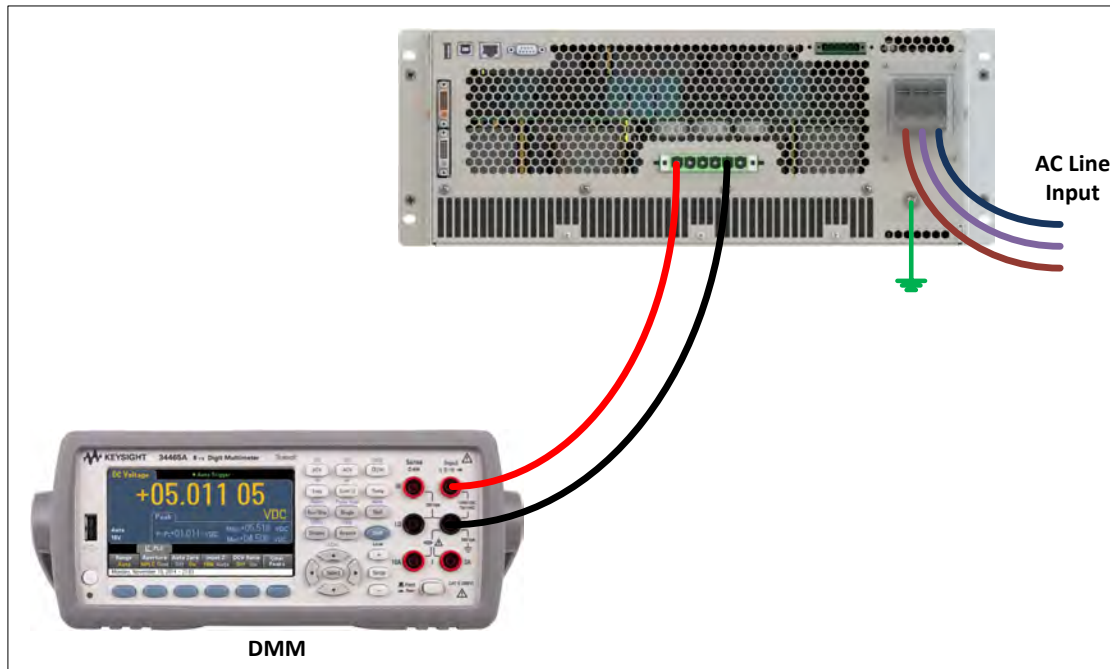
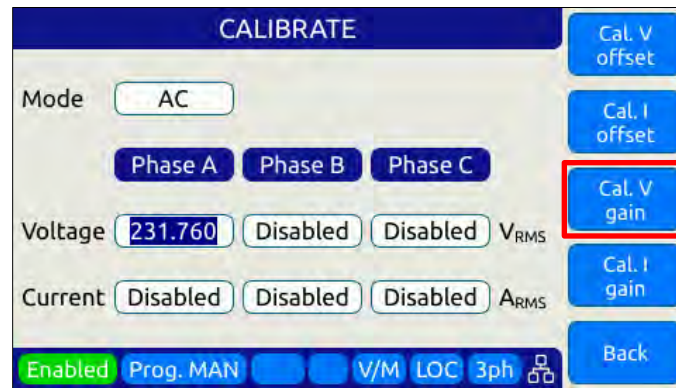

Figure 11-1: Voltage Calibration Equipment Setup – 1 or 3 Phase Mode – Phase A

The procedure to calibrate voltage gain is:



1. Select the Calibration entry from the “System” menu
2. Press the “Calibrate” soft key to enter calibration mode
3. Do not connect any load to the output
4. Program AC voltage to full scale 300.0 Vrms L-N for AC mode calibration or 425Vdc for DC mode calibration on all phases. Use the PROGRAM screen for this.
5. For AC mode calibration, set the Frequency to the most commonly used value depending on typical applications
6. NOTE: If the user calibration is targeted for specific operating conditions, for example Vac = 115V L-N and Freq = 400 Hz, use these settings instead of those suggested in steps 4 and 5

7. Enable the Output with no load connected
8. Enter the DMM VAC readings for all three phase in the respective Voltage data entry text boxes in the Calibration screen. Move the DMM probe from phase A, to B to C respectively to obtain each phase reading.
9. Press "Cal V. gain" soft key
10. Wait for the V gain coefficients for all phases to be calculated and displayed

Note: Voltage gain can be calibrated in DC mode as well if this is the predominant mode of use. Use the MODE fields at the top to select the desired mode.

11.4.4 Current Gain Calibration Setup Diagrams

For current calibration, a resistive load equivalent to 90% of maximum available RMS phase current for the phase mode selected is recommended. It is permissible to use only one load and move it between phases for three-phase mode calibration. For single-phase mode current calibration, a load capable of supporting 90% of maximum available single-phase current is recommended. The A, B and C outputs must be shorted together for single-phase mode operation. The optional Single Phase Shorting Connector (P/N 160086) can be used to accomplish this.

Note: To guarantee that the current doesn't change during the calibration process, it is recommended that the unit is operated at current limit, but reducing its set point to the desired value. It is also recommended to use a stable load that provides a constant linear impedance to the unit.

A suitable current shunt must be connected in series with the load as shown below for three-phase mode. The sense terminals of the current shunt must be connected to the DMM Voltage input.

Three Phase Mode Setup

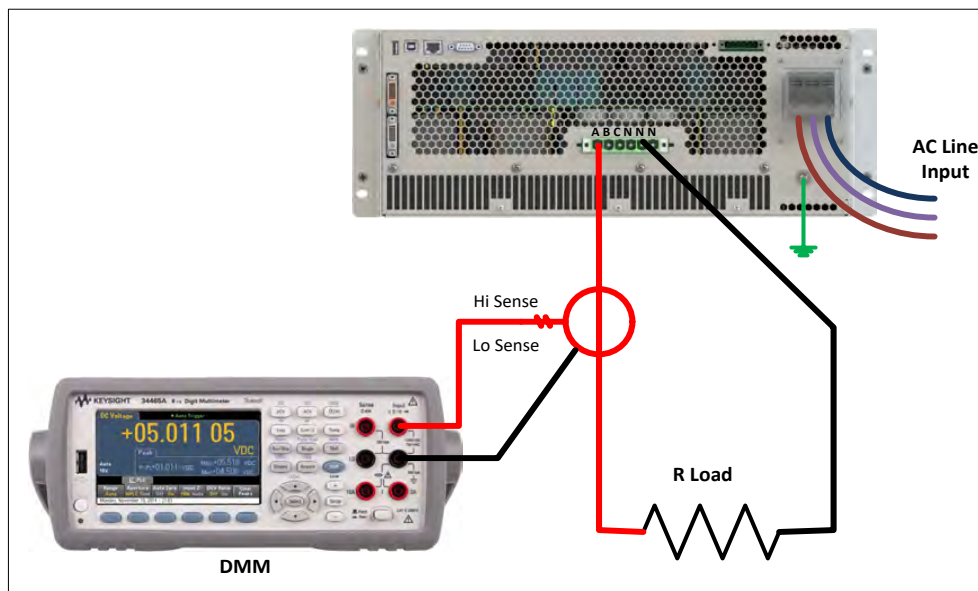

Figure 11-2: Current Calibration Equipment Setup – 3 Phase Mode – Phase A

Single Phase Mode Setup

For Single-phase mode current Calibration, the load must have the appropriate size. See next section for recommended load value by model and phase mode.

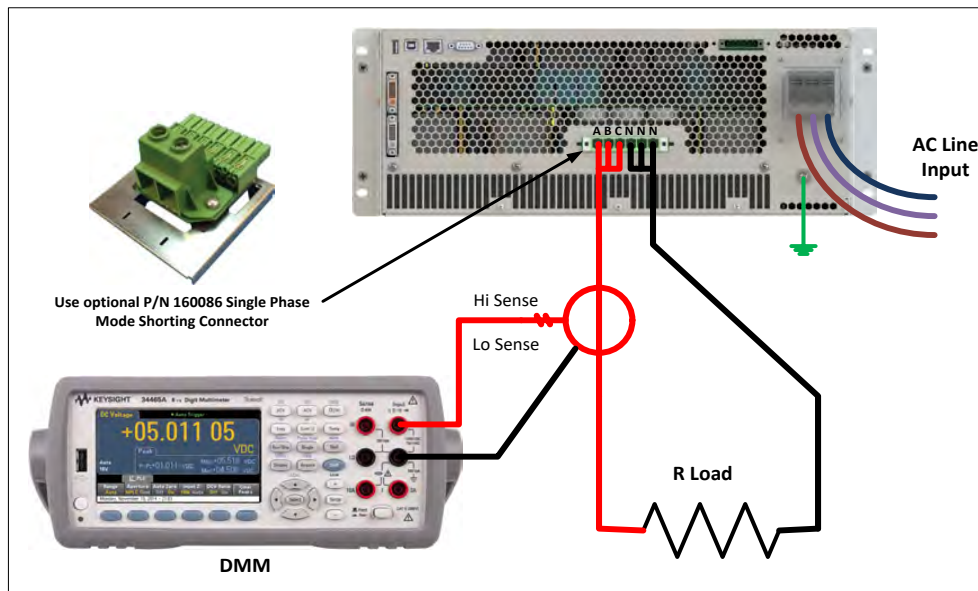

Figure 11-3: Current Calibration Equipment Setup – 1 Phase Mode

11.4.1 Current Calibration Load Values

Full-scale current gain calibration is best performed at current levels that are around 90% of full scale current. Since the AFX Series® has only a single voltage range, maximum RMS current is available at 120Vrms L-N for each phase. For single-phase mode, the current is three times higher. Thus, to obtain 90% of load current, resistor value that is sized to draw this current level at around 120Vrms is required. Since the maximum current varies by model and phase mode, the table below shows the recommended resistor values or resistive load bank settings.

Model	Rating/phs VA/W	Three & Two Phase Mode Calibration			Single Phase Mode Calibration		
		Max. I _{rms} /phs	Current (90%)	Recommended R Load (Ohm)	Max/ I _{rms}	Current (90%)	Recommended R Load (Ohm)
360AFX	2000	16.7	15	8.00	50	45	2.67
390AFX	3000	25.0	23	5.33	75	68	1.78
3120AFX	4000	33.3	30	4.00	100	90	1.33
3150AFX	5000	41.7	38	3.20	125	113	1.07
3180AFX	6000	50.0	45	2.67	150	135	0.89
3240AFX	8000	66.7	60	2.00	200	180	0.67
3300AFX	10000	83.3	75	1.60	250	225	0.53
3450AFX	15000	125.0	113	1.07	375	338	0.36
3600AFX	20000	166.7	150	0.80	500	450	0.27

Table 11-3: Calibration Load Values by Model and Phase Mode

11.4.2 Current Calibration - Gain

The procedure to calibrate current gain is:

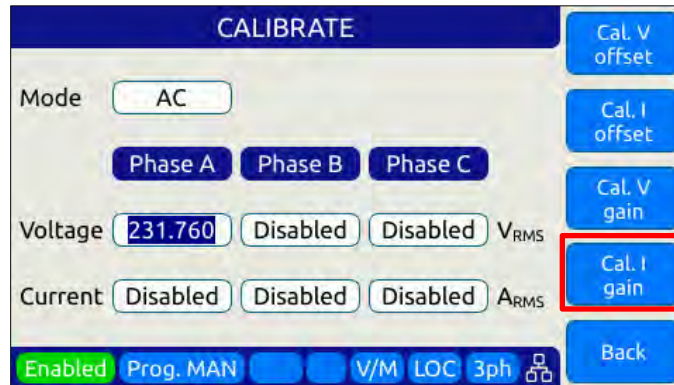

1. Select the Calibration entry from the “**System**” menu
2. Press the “Calibrate” soft key to enter calibration mode
3. Connect the required resistive load value to the output of phase A or all three outputs if three loads are available.
4. Program AC voltage to 120.0 Vrms L-N on all phases
5. Set the Frequency to the most commonly used value depending on typical applications
6. Enable the Output
7. Allow the load current to stabilize by monitoring the DMM current reading for each phase.
8. Enter the DMM VAC readings for all three phase in the respective Current data entry text boxes in the Calibration screen. If only one shunt and load is available, repeat the above steps for phase B and C making sure to turn OFF the output before moving the load and shunt to the next phase.
9. Press "Cal I. gain" soft key
10. Wait for the I gain coefficients for all phases to be calculated and displayed

Note: Current gain can be calibrated in DC mode as well if this is the predominant mode of use. Use the MODE fields at the top to select the desired mode.

11.4.3 Exit Calibration Mode

To exit the calibration mode once done, press the “**Back**” software.

12 Warnings & Error Messages

12.1 Preface

During normal operation, a series of error and/ or warning messages may be displayed on the front panel LCD display or reported by the error queue over one of the remote control interfaces. This section of the manual lists available warning and error messages in numerical order and provided some additional information on their meaning and possible causes. Where relevant, suggested remedies to resolve any conditions are included as well.

Note: There are some Error and Warning messages that may appear in the Errors & Events that are **NOT** listed in the next section. In case you encounter an unlisted error or warning message and code, contact Pacific Power customer service (support@pacificpower.com) and describe the number and description to obtain further information.

After reporting such an event, try rebooting the power sources by cycling power as most of these conditions will clear up with a reboot.

12.2 Errors & Warnings Messages in Numeric Order

Source	Code	Type	Description	Possible cause
Frontpanel	-500	"SCPI standard event"	"Event: Power ON."	Power on event detected. Normal after power on
Frontpanel	-350	"SCPI standard event"	"E&E queue overflow."	
Frontpanel	-360	"SCPI standard error"	"Communication error with an interface."	
Frontpanel	-320	"SCPI standard error"	"Storage fault."	
Frontpanel	-310	"SCPI standard error"	"System error"	
Frontpanel	-290	"SCPI standard error"	"Execution error: Memory use error."	
Frontpanel	-286	"SCPI standard error"	"Execution error: Not allowed command with the current configuration."	
Frontpanel	-285	"SCPI standard error"	"Execution error: Program syntax error."	
Frontpanel	-284	"SCPI standard error"	"Execution error: Program is currently running."	
Frontpanel	-282	"SCPI standard error"	"Execution error: Invalid program name."	
Frontpanel	-281	"SCPI standard error"	"Execution error: Cannot create program."	
Frontpanel	-256	"SCPI standard error"	"Execution error: File not found."	
Frontpanel	-253	"SCPI standard error"	"Execution error: Media is corrupted."	
Frontpanel	-240	"SCPI standard error"	"Execution error: Hardware error."	
Frontpanel	-224	"SCPI standard error"	"Execution error: Illegal parameter value."	
Frontpanel	-222	"SCPI standard error"	"Execution error: Argument out of range."	
Frontpanel	-221	"SCPI standard error"	"Execution error: Conflict in configuration setting."	
Frontpanel	-203	"SCPI standard error"	"Execution error: Permission denied."	
Frontpanel	-158	"SCPI standard error"	"Command error: String data is not allowed."	
Frontpanel	-138	"SCPI standard error"	"Command error: Numeric suffix is invalid."	

Source	Code	Type	Description	Possible cause
Frontpanel	-131	"SCPI standard error"	"Command error: Numeric suffix is out of range."	
Frontpanel	-113	"SCPI standard error"	"Command error: Undefined header."	
Frontpanel	-109	"SCPI standard error"	"Command error: Invalid number of parameters."	
Frontpanel	-108	"SCPI standard error"	"Command error: Parameters error."	
Frontpanel	-103	"SCPI standard error"	"Command error: Invalid separator."	
Frontpanel	-102	"SCPI standard error"	"Command error: Syntax error."	
Frontpanel	18	"Error"	"Unavailable transient element."	
Frontpanel	19	"Error"	"Maximum number of transient elements."	
Frontpanel	21	"Error"	"Internal communication: error during SDO upload."	
Frontpanel	22	"Error"	"Internal communication: error during SDO download."	
Frontpanel	29	"Error"	"USB interface unknown state."	
Frontpanel	31	"Error"	"Interface request packet	Not empty."
Frontpanel	32	"Error"	"Interface request packet	Unknown type"
Frontpanel	33	"Error"	"Interface request packet	Incompatible type."
Frontpanel	34	"Error"	"Interface request packet out of space."	
Frontpanel	35	"Error"	"Interface request packet	Unavailable command request
Frontpanel	36	"Error"	"Interface request packet has invalid arguments."	
Frontpanel	37	"Error"	"Interface response packet out of space."	
Frontpanel	42	"Error"	"Memory in use was removed."	
Frontpanel	47	"Error"	"Front panel is shutting down."	
Frontpanel	48	"Error"	"Fault state cannot be automatically reset."	
Frontpanel	51	"Error"	"The command cannot be executed in auxiliary unit."	
Frontpanel	53	"Error"	"Error during firmware update."	
Frontpanel	54	"Error"	"Calibration coefficient cannot be negative."	
Frontpanel	57	"Error"	"Waveform is not available."	
Frontpanel	58	"Error"	"Waveforms lengths are different between inverter controllers."	
Frontpanel	59	"Error"	"Unit does not exist."	
Frontpanel	60	"Error"	"Cannot read ambient temperature."	
Frontpanel	64	"Error"	"Unexpected reset."	
Frontpanel	65	"Error"	"Front panel is in passive mode."	
Frontpanel	66	"Error"	"Invalid host name."	
Frontpanel	67	"Error"	"DC voltage setpoint cannot change due to waveform saturation."	
Frontpanel	68	"Error"	"AC voltage setpoint cannot change due to waveform saturation."	
Frontpanel	69	"Error"	"Maximum user limit is lower than setpoint."	

Source	Code	Type	Description	Possible cause
Frontpanel	70	"Error"	"Minimum user limit is higher than setpoint."	
Frontpanel	72	"Error"	"Minimum limit is higher than maximum."	
Frontpanel	73	"Error"	"Maximum limit is lower than minimum."	
Frontpanel	75	"Error"	"IP address conflict. May be duplicated."	
Frontpanel	76	"Error"	"Invalid filename."	
Frontpanel	77	"Error"	"External memory storage is not available."	
Frontpanel	78	"Error"	"Datalogger rate not allowed."	
Frontpanel	79	"Error"	"Datalogger is running"	Yyou must stop it to change the configuration
Frontpanel	80	"Error"	"Datalogger execution error."	
Frontpanel	83	"Error"	"Internal error: File system partition blocked."	
Frontpanel	84	"Error"	"Unable to change form while output is enabled."	
Frontpanel	85	"Error"	"Unable to clear one or more fault."	
Frontpanel	86	"Error"	"Unable to enable output. One or more primary stages failed to enable."	
Frontpanel	89	"Error"	"Digital I/Os interface conflict: Remote inhibit is active."	
Frontpanel	90	"Error"	"Digital I/Os interface conflict: Remote enable is active."	
Frontpanel	91	"Error"	"Internal error: Unknown phase mode."	
Frontpanel	92	"Error"	"Unable to disable output. One or more primary stages failed to disable."	
Frontpanel	95	"Error"	"Digital I/Os interface conflict: Serial interface flow control is active."	
Frontpanel	96	"Error"	"Datalogger storage error."	
Frontpanel	97	"Error"	"Output enable in progress."	
Frontpanel	98	"Error"	"DC Voltage not allowed in "AC mode"."	
Frontpanel	99	"Error"	"AC Voltage not allowed in "DC mode"."	
Frontpanel	100	"Error"	"DC voltage setpoint cannot change due to user limit."	
Frontpanel	101	"Error"	"AC voltage setpoint cannot change due to user limit."	
Frontpanel	102	"Error"	"DC voltage setpoint cannot change due to low range."	
Frontpanel	103	"Error"	"AC voltage setpoint cannot change due to low range."	
Frontpanel	104	"Error"	"Waveform change in progress."	
Frontpanel	105	"Error"	"Error changing service name"	
Frontpanel	106	"Error"	"Error getting service name"	
Frontpanel	109	"Error"	"Transient step mode not available on UPC compatible mode."	
Frontpanel	110	"Error"	"System is about to reboot."	
Frontpanel	111	"Error"	"Cannot reboot system."	
Frontpanel	115	"Error"	"Unable to renew the DHCP lease. Changing to Auto-IP mode."	

Source	Code	Type	Description	Possible cause
Frontpanel	116	"Error"	"Failed starting firmware update."	
Frontpanel	117	"Error"	"Unable to execute this action with output enabled."	
Frontpanel	118	"Error"	"Frequency setpoint cannot change due to waveform saturation."	
Frontpanel	119	"Error"	"Frequency setpoint cannot change due to user limit."	
Frontpanel	120	"Error"	"Frequency not allowed in "DC mode"."	
Frontpanel	121	"Error"	"Waveform setpoint cannot change due to waveform saturation."	
Frontpanel	122	"Error"	"Cannot load program. Run PROG:CHECK? for more information."	
Frontpanel	125	"Error"	"Remote inhibit cannot be disabled in this model."	
Frontpanel	126	"Error"	"Line to line measurements only available with sinewaves."	
Frontpanel	127	"Error"	"Digital I/Os interface conflict: Single-Phase relay control is active."	
Frontpanel	128	"Error"	"Digital I/Os interface conflict: Single-Phase relay cannot change with output enabled."	
Frontpanel	129	"Error"	"Digital I/Os interface conflict: Single-Phase relay cannot change due relay closed."	
Frontpanel	130	"Error"	"Unable to disable output. One or more inverter stages failed to disable."	
Frontpanel	131	"Error"	"Cannot set EEPROM field"	
Frontpanel	132	"Error"	"EEPROM field already set"	
Frontpanel	133	"Error"	"Cannot read EEPROM field"	
Frontpanel	148	"Error"	"Serial number mismatch: Front panel does not match power stages."	
Frontpanel	150	"Error"	"Suffix not allowed in single form."	
Frontpanel	151	"Error"	"Suffix not allowed in split form."	
Frontpanel	152	"Error"	"Peak current limit setting is too low for the desired voltage and frequency."	
Frontpanel	153	"Error"	"Program transient trigger input is disabled."	
Frontpanel	154	"Error"	"Steady state not yet stabilized."	
Frontpanel	155	"Error"	"Trigger output not available in this model."	
Frontpanel	156	"Error"	"Trigger input not available in this model."	
Frontpanel	157	"Error"	"Filter size must be an odd number."	
Frontpanel	158	"Error"	"Voltage mode not available in UPC compatible mode."	
Frontpanel	159	"Error"	"Waveform is unique in UPC compatible mode."	
Frontpanel	160	"Error"	"Phase is 180 for split in UPC compatible mode."	
Frontpanel	161	"Error"	"Voltage AC is unique in UPC compatible mode."	
Frontpanel	162	"Error"	"CSC is always disabled during transient in UPC compatible mode."	
Frontpanel	163	"Error"	"Auto RMS is always enabled in UPC compatible mode."	

Source	Code	Type	Description	Possible cause
Frontpanel	166	"Error"	"Unable to set extended voltage because frequency is outside the allowed range."	
Frontpanel	169	"Error"	"Unable to update setpoint because it is outside the allowed range of extended voltage mode."	
Frontpanel	172	"Error"	"Command not allowed during power stage firmware update."	
Frontpanel	173	"Error"	"Cannot change Current RMS Overload mode with output enabled."	
Frontpanel	174	"Error"	"Strobe feature not available in this model."	
Frontpanel	175	"Error"	"Feature not available in this model."	
Frontpanel	176	"Error"	"Setpoints cannot be changed while transient program is running."	
Frontpanel	177	"Error"	"Cycle reset is always enabled in UPC compatible mode."	
Frontpanel	178	"Error"	"Command not available in this unit model."	
Frontpanel	179	"Error"	"Digital output is being used for transformer option."	
Frontpanel	180	"Error"	"Unknown processor type detected. Run unit discovery to recover."	
Frontpanel	181	"Error"	"Undiscovered node detected. Run unit discovery to recover."	
Frontpanel	182	"Error"	"Incorrect parallel unit count"	
Frontpanel	183	"Error"	"Invalid processor type"	
Frontpanel	184	"Error"	"Daisy chain invalid type"	
Frontpanel	185	"Error"	"Undiscovered controller node was detected. "	
Frontpanel	186	"Error"	"No master front panel was detected."	
Frontpanel	187	"Error"	"More than enabled master controller is was detected. Going to inactive state."	
Frontpanel	188	"Error"	"One or more units are not energized or have a failure."	
Frontpanel	189	"Error"	"Incompatible node detected."	
Frontpanel	190	"Error"	"Master unit nodes not found."	
Frontpanel	191	"Error"	"Fastscan failed."	
Frontpanel	192	"Error"	"Undetectable node exists."	
Frontpanel	193	"Error"	"An invalid firmare type exists."	
Frontpanel	501	"Error"	"Frequency is too high to enable xfmr coupling."	
Frontpanel	502	"Error"	"Extended voltage range is not allowed when overload modes are enabled."	
Frontpanel	503	"Error"	"Frequency is too high for extended voltage mode."	
Frontpanel	504	"Error"	"Cannot change extended voltage mode with output enabled."	
Frontpanel	505	"Error"	"Cannot enable current overload mode when extended voltage range is enabled."	
Frontpanel	506	"Error"	"Cannot enable extended frequency when extended voltage range is enabled."	
Frontpanel	509	"Error"	"Setpoint out of range due to extended frequency mode."	

Source	Code	Type	Description	Possible cause
Frontpanel	510	"Error"	"Unable to update setpoint because it is outside the allowed range of extended frequency mode."	
Frontpanel	511	"Error"	"Error during power stage firmware update."	
Frontpanel	512	"Error"	"Phase rotation is always negative in UPC compatible mode."	
Frontpanel	513	"Error"	"Cannot change split phase mode with output enabled."	
Frontpanel	514	"Error"	"Serial port flow control not available in this unit."	
Frontpanel	515	"Error"	"Too many commands per line."	
Frontpanel	518	"Error"	"Cannot change output impedance state with output enabled."	
Frontpanel	519	"Error"	"Cannot change output impedance mode with output enabled."	
Frontpanel	520	"Error"	"Inductive impedance not available in UPC compatible mode."	
Frontpanel	521	"Error"	"Read only file or folder."	
Frontpanel	522	"Error"	"Argument requires more decimals."	
Frontpanel	524	"Error"	"Digital I/Os interface conflict: Serial interface is active."	
Frontpanel	525	"Error"	"New IO firmware available. Must split system in two to perform update."	
Frontpanel	526	"Error"	"Cannot export configurations."	
Frontpanel	527	"Error"	"Cannot import configurations."	
Frontpanel	528	"Error"	"Version mismatch error."	
Frontpanel	529	"Error"	"Internal connection error with the power stage."	
Frontpanel	530	"Error"	"Fault during output enable."	
Frontpanel	531	"Error"	"Incorrect password."	
Frontpanel	533	"Error"	"This setpoint is being set by an analog input."	
Frontpanel	534	"Error"	"Image model not compatible."	
Frontpanel	535	"Error"	"Frontpanel not compatible."	
Frontpanel	536	"Error"	"Cannot convert cycle based transient to time based."	
Frontpanel	537	"Error"	"Cannot load pulse."	
Frontpanel	539	"Error"	"Parameter below minimum saturation."	
Frontpanel	540	"Error"	"Parameter below minimum range."	
Frontpanel	541	"Error"	"Parameter below minimum unit scope."	
Frontpanel	542	"Error"	"Parameter below minimum user limit."	
Frontpanel	543	"Error"	"Parameter below voltage mode."	
Frontpanel	544	"Error"	"Parameter above maximum saturation."	
Frontpanel	545	"Error"	"Parameter above maximum range."	
Frontpanel	546	"Error"	"Parameter above maximum unit scope."	
Frontpanel	547	"Error"	"Parameter above maximum user limit."	
Frontpanel	548	"Error"	"Parameter above voltage mode."	

Source	Code	Type	Description	Possible cause
Frontpanel	549	"Error"	"Locked unit	Please unlock with command SYST:UNLOCK PASSWORD
Frontpanel	550	"Error"	"Unit model changed to ADF."	
Frontpanel	551	"Error"	"Series parallel mode switch not available."	
Frontpanel	552	"Error"	"Series connection requires an even number of units."	
Frontpanel	553	"Error"	"Digital output is being used for series units option."	
Frontpanel	554	"Error"	"Series connection is disabled. A Series connection should be set with SYSTem:SERIES command."	
Frontpanel	555	"Error"	"Transformer option is configured."	
Frontpanel	556	"Error"	"Series connection option is configured."	
Frontpanel	557	"Error"	"Series connection not detected."	
Frontpanel	558	"Error"	"Series connection inhibit."	
Frontpanel	559	"Error"	"Digital input 3 is fixed to series connection inhibit."	
Frontpanel	560	"Error"	"Series connection requires series remote sense board."	
Frontpanel	561	"Error"	"Series connection incorrect units order."	
Frontpanel	562	"Error"	"Series connection protection cannot be disabled."	
Frontpanel	71	"Warning"	"Setpoint reduced due to low range."	
Frontpanel	107	"Warning"	"Redundant segments were combined."	
Frontpanel	108	"Warning"	"Redundant steps were combined."	
Frontpanel	144	"Warning"	"Internal battery needs to be replaced."	
Frontpanel	164	"Warning"	"Warning: CSC is enabled and Auto-RMS is disabled. Output RMS may not be regulated properly."	
Frontpanel	165	"Warning"	"Maximum AC voltage limit was reduced due to extended voltage range."	
Frontpanel	167	"Warning"	"Power limits were reduced due to extended voltage range."	
Frontpanel	168	"Warning"	"AC voltage setpoints and/or AC voltage maximum limit were reduced due to extended voltage range."	
Frontpanel	171	"Warning"	"Warning: Repeated waveform alias."	
Frontpanel	500	"Warning"	"AC voltage setpoint was automatically reduced to 0 Vrms."	
Frontpanel	507	"Warning"	"Power limits were reduced due to extended frequency mode."	
Frontpanel	508	"Warning"	"Current limits were reduced due to extended frequency mode."	
Frontpanel	516	"Warning"	"Resistive impedance was automatically reduced."	
Frontpanel	517	"Warning"	"Inductive impedance was automatically reduced."	
Frontpanel	523	"Warning"	"Warning: Ambient temperature approaching limit."	

Source	Code	Type	Description	Possible cause
Frontpanel	532	"Warning"	"Frontpanel firmware image model do not match frontpanel model."	
Frontpanel	563	"Warning"	"VLL estimation accuracy is lower."	
Frontpanel	331	"Fault"	"Unit discovery fault. Run unit discovery to recover."	
Frontpanel	332	"Fault"	"Undiscovered unit/node detected. Run unit discovery to recover."	
Frontpanel	334	"Fault"	"Power failure."	
Frontpanel	335	"Fault"	"Remote inhibit was issued from remote interface."	
Frontpanel	336	"Fault"	"System about to reboot."	
Frontpanel	338	"Fault"	"One or more inverters did not get enabled."	
Frontpanel	339	"Fault"	"One or more primaries did not get enabled."	
Frontpanel	342	"Fault"	"Mismatch between hardware revision of units in parallel."	
Frontpanel	343	"Fault"	"Power stage firmware update failed. Run SYSTEM:FW:INT:UPDATE:STAT? for more information. Run unit discovery to recover."	
Frontpanel	344	"Fault"	"Firmware update was interrupted"	Recovery is needed. Run unit discovery to recover."
Frontpanel	345	"Fault"	"GPIB hardware not found in this unit."	
Frontpanel	346	"Fault"	"GPIB hardware detected"	Unit model mismatch."
Frontpanel	347	"Fault"	"IO hardware not found in this unit."	
Frontpanel	348	"Fault"	"IO hardware detected"	Unit model mismatch."
Frontpanel	350	"Fault"	"Transformer hardware detected"	Unit model mismatch."
Frontpanel	351	"Fault"	"Ambient temperature exceeded maximum limit."	
Frontpanel	352	"Fault"	"Mismatch between models of units in parallel."	
Frontpanel	353	"Fault"	"Unit model mismatch."	
Frontpanel	355	"Fault"	"Series connection hardware detected"	Unit model mismatch."
Frontpanel	329	"Internal fault"	"Global fault detected."	
Frontpanel	330	"Internal fault"	"Global fault detected. Possible unenergized unit or node."	
Frontpanel	333	"Internal fault"	"Node in non-operational mode. Run unit discovery to recover."	
Frontpanel	337	"Internal fault"	"Missed node."	
Frontpanel	340	"Internal fault"	"Firmware version mismatch. Power stage version is older than expected. Contact technical support."	
Frontpanel	341	"Internal fault"	"Firmware version mismatch. Front panel version is older than expected. Contact technical support."	
Frontpanel	349	"Internal fault"	"Analog inputs cannot be read."	

Source	Code	Type	Description	Possible cause
Frontpanel	354	"Internal fault"	"Digital inputs cannot be read."	
Frontpanel	356	"Internal fault"	"Did not receive MDO 1 - Inverter A."	
Frontpanel	357	"Internal fault"	"Did not receive MDO 2 - Inverter A."	
Frontpanel	358	"Internal fault"	"Did not receive MDO 3 - Inverter A."	
Frontpanel	359	"Internal fault"	"Did not receive MDO 4 - Inverter A."	
Frontpanel	360	"Internal fault"	"Did not receive MDO 5 - Inverter A."	
Frontpanel	361	"Internal fault"	"Did not receive MDO 6 - Inverter A."	
Frontpanel	362	"Internal fault"	"Did not receive MDO 7 - Inverter A."	
Frontpanel	363	"Internal fault"	"Did not receive MDO 8 - Inverter A."	
Frontpanel	364	"Internal fault"	"Did not receive MDO 9 - Inverter A."	
Frontpanel	365	"Internal fault"	"Did not receive MDO 10 - Inverter A."	
Frontpanel	366	"Internal fault"	"Did not receive MDO 1 - Inverter B."	
Frontpanel	367	"Internal fault"	"Did not receive MDO 2 - Inverter B."	
Frontpanel	368	"Internal fault"	"Did not receive MDO 3 - Inverter B."	
Frontpanel	369	"Internal fault"	"Did not receive MDO 4 - Inverter B."	
Frontpanel	370	"Internal fault"	"Did not receive MDO 5 - Inverter B."	
Frontpanel	371	"Internal fault"	"Did not receive MDO 6 - Inverter B."	
Frontpanel	372	"Internal fault"	"Did not receive MDO 7 - Inverter B."	
Frontpanel	373	"Internal fault"	"Did not receive MDO 8 - Inverter B."	
Frontpanel	374	"Internal fault"	"Did not receive MDO 1 - Inverter C."	
Frontpanel	375	"Internal fault"	"Did not receive MDO 2 - Inverter C."	
Frontpanel	376	"Internal fault"	"Did not receive MDO 3 - Inverter C."	
Frontpanel	377	"Internal fault"	"Did not receive MDO 4 - Inverter C."	
Frontpanel	378	"Internal fault"	"Did not receive MDO 5 - Inverter C."	
Frontpanel	379	"Internal fault"	"Did not receive MDO 6 - Inverter C."	
Frontpanel	380	"Internal fault"	"Did not receive MDO 7 - Inverter C."	
Frontpanel	381	"Internal fault"	"Did not receive MDO 8 - Inverter C."	
Frontpanel	1	"Internal error"	"Unknown fault or error."	
Frontpanel	2	"Internal error"	"Cannot initialize command thread."	
Frontpanel	3	"Internal error"	"Cannot initialize global semaphore."	
Frontpanel	4	"Internal error"	"Cannot create SCPI status object."	
Frontpanel	5	"Internal error"	"Cannot create network manager object."	
Frontpanel	6	"Internal error"	"Cannot initialize CANOpen stack."	
Frontpanel	7	"Internal error"	"Cannot initialize process class array."	
Frontpanel	8	"Internal error"	"Cannot initialize local CANOpen object dictionary."	
Frontpanel	9	"Internal error"	"Cannot create FastCGI interface."	
Frontpanel	10	"Internal error"	"Cannot create TCP interface."	
Frontpanel	11	"Internal error"	"Cannot create TELNET interface."	
Frontpanel	12	"Internal error"	"Cannot create UART serial interface."	
Frontpanel	13	"Internal error"	"Cannot create USB serial interface."	

Source	Code	Type	Description	Possible cause
Frontpanel	14	"Internal error"	"Cannot create keyboard interface."	
Frontpanel	15	"Internal error"	"Cannot create front panel interface."	
Frontpanel	16	"Internal error"	"Cannot create SCPI program interface."	
Frontpanel	17	"Internal error"	"Cannot cast process class in runtime."	
Frontpanel	20	"Internal error"	"Unknown operation."	
Frontpanel	23	"Internal error"	"Unavailable node."	
Frontpanel	24	"Internal error"	"Cannot initialize GPIO library."	
Frontpanel	25	"Internal error"	"Process class: not implemented type."	
Frontpanel	25	"Internal error"	"Cannot attach GPIO."	
Frontpanel	26	"Internal error"	"Process class: invalid initialization."	
Frontpanel	27	"Internal error"	"SCPI program dynamic cast."	
Frontpanel	28	"Internal error"	"Cannot initialize node discovery."	
Frontpanel	38	"Internal error"	"Static null pointer."	
Frontpanel	39	"Internal error"	"Cannot create file system object"	
Frontpanel	40	"Internal error"	"Linux system call error"	
Frontpanel	41	"Internal error"	"XML library error."	
Frontpanel	43	"Internal error"	"Cannot create fault manager interface."	
Frontpanel	44	"Internal error"	"Global fault UIO driver."	
Frontpanel	45	"Internal error"	"Global fault interrupt disabled."	
Frontpanel	46	"Internal error"	"Cannot create global fault thread."	
Frontpanel	49	"Internal error"	"Cannot initialize communications reset mutex."	
Frontpanel	50	"Internal error"	"Cannot initialize communications reset condition variable."	
Frontpanel	52	"Internal error"	"Error in internal communications heartbeat."	
Frontpanel	55	"Internal error"	"Cannot initialize waveform manager."	
Frontpanel	61	"Internal error"	"Cannot initialize firmware update manager."	
Frontpanel	62	"Internal error"	"Cannot initialize buffer manager."	
Frontpanel	81	"Internal error"	"Internal error: Socket send error."	
Frontpanel	82	"Internal error"	"Internal error: Interface request packet has incorrect CRC."	
Frontpanel	87	"Internal error"	"Internal error: Cannot get system time."	
Frontpanel	88	"Internal error"	"Internal error: Unknown sequence."	
Frontpanel	93	"Internal error"	"Internal error: Cannot configure timer."	
Frontpanel	94	"Internal error"	"Internal error: Cannot create timer."	
Frontpanel	136	"Internal error"	"NVRAM CRC mismatch"	
Frontpanel	137	"Internal error"	"NVRAM cannot open."	
Frontpanel	138	"Internal error"	"NVRAM cannot close."	
Frontpanel	139	"Internal error"	"NVRAM cannot lock."	
Frontpanel	140	"Internal error"	"NVRAM cannot unlock."	
Frontpanel	141	"Internal error"	"NVRAM cannot read."	

Source	Code	Type	Description	Possible cause
Frontpanel	142	"Internal error"	"NVRAM cannot write."	
Frontpanel	143	"Internal error"	"Cannot reset EEPROM."	
Frontpanel	145	"Internal error"	"NVRAM hardware error. Using temporal storage."	
Frontpanel	146	"Internal error"	"Invalid command ID."	
Frontpanel	147	"Internal error"	"Command argument not exist."	
Frontpanel	149	"Internal error"	"This does not seems to be a front panel."	
Frontpanel	2000	"Internal error"	"Command request argument: argument cannot be null."	
Frontpanel	2001	"Internal error"	"Command request argument: cannot parse unknown argument."	
Frontpanel	2002	"Internal error"	"Command request argument: cannot parse argument."	
Frontpanel	2003	"Internal error"	"Command request argument: cannot append string to non string argument."	
Frontpanel	2004	"Internal error"	"Command request argument: cannot serialize due to small buffer."	
Frontpanel	2005	"Internal error"	"Command request argument: cannot deserialize due to small buffer."	
Frontpanel	2006	"Internal error"	"Command request argument: cannot get string due non string argument."	
Frontpanel	2007	"Internal error"	"EEPROM Data: Write header error."	
Frontpanel	2008	"Internal error"	"EEPROM Data: Write data error."	
Frontpanel	2009	"Internal error"	"EEPROM Data: Data too big."	
Frontpanel	2010	"Internal error"	"EEPROM Data: Cannot open temporal file."	
Frontpanel	2011	"Internal error"	"EEPROM Data: Close error."	
Frontpanel	2012	"Internal error"	"EEPROM Data: Offset error."	
Frontpanel	2013	"Internal error"	"EEPROM Data: Read error."	
Frontpanel	2014	"Internal error"	"Transformer: Corrupted internal database."	
Frontpanel	2015	"Internal error"	"XFMR ratio not found."	
Frontpanel	2016	"Internal error"	"Coupling cannot be changed with output enabled."	
Frontpanel	2017	"Internal error"	"XFMR ratio cannot be changed with output enabled."	
Frontpanel	2018	"Internal error"	"Transformer option not available in this model."	
Frontpanel	2019	"Internal error"	"XFMR ratio is disabled. A XFMR ratio should be set with SYSTEM:XFMR RATIO command."	
Frontpanel	2020	"Internal error"	"Transformer control circuits not detected."	
Frontpanel	2021	"Internal error"	"DC voltage not allowed with transformer coupling."	
Frontpanel	2022	"Internal error"	"Command request: command request cannot be null."	
Frontpanel	2023	"Internal error"	"Command request: command request argument is null."	
Frontpanel	2024	"Internal error"	"Command request: argument is null."	
Frontpanel	2025	"Internal error"	"Command request: argument number is null."	

Source	Code	Type	Description	Possible cause
Frontpanel	2026	"Internal error"	"Command request: argument number does not exist."	
Frontpanel	2027	"Internal error"	"Command request: there are no arguments."	
Frontpanel	2028	"Internal error"	"Command request: cannot serialize due small buffer."	
Frontpanel	2029	"Internal error"	"Command request: cannot deserialize due small buffer."	
Frontpanel	2030	"Internal error"	"Command request: cannot deserialize due argument count mismatch."	
Frontpanel	2031	"Internal error"	"Command request: cannot deserialize due size mismatch."	
Frontpanel	2032	"Internal error"	"Command request vector: request number does not exist."	
Frontpanel	2033	"Internal error"	"Command request vector: request number is null."	
Frontpanel	2034	"Internal error"	"Command request vector: request is null."	
Frontpanel	2035	"Internal error"	"Command request vector: vector is empty."	
Frontpanel	2036	"Internal error"	"Command request vector: cannot serialize due small buffer."	
Frontpanel	2037	"Internal error"	"Command request vector: cannot deserialize due small buffer."	
Frontpanel	2038	"Internal error"	"Command request vector: cannot deserialize due command count mismatch."	
Frontpanel	2039	"Internal error"	"Command request vector: cannot deserialize due size mismatch."	
Frontpanel	2040	"Internal error"	"Interface request packet: cannot deserialize due size mismatch."	
Frontpanel	2041	"Internal error"	"Command thread: cannot post command semaphore."	
Frontpanel	2042	"Internal error"	"Command thread: cannot initialize command semaphore."	
Frontpanel	2043	"Internal error"	"Debug message file: seek file error."	
Frontpanel	2044	"Internal error"	"Debug message file: tell file error."	
Frontpanel	2045	"Internal error"	"Debug message file: close file error."	
Frontpanel	2046	"Internal error"	"Debug message file: open file error."	
Frontpanel	2047	"Internal error"	"Debug message file: write file error."	
Frontpanel	2048	"Internal error"	"Debug message file: flush file error."	
Frontpanel	2049	"Internal error"	"Debug message file: unlink file error."	
Frontpanel	2050	"Internal error"	"Debug message ring buffer: cannot allocate buffer."	
Frontpanel	2051	"Internal error"	"Debug message ring buffer: seek file error."	
Frontpanel	2052	"Internal error"	"Debug message ring buffer: tell file error."	
Frontpanel	2053	"Internal error"	"Debug message ring buffer: close file error."	
Frontpanel	2054	"Internal error"	"Debug message ring buffer: open file error."	
Frontpanel	2055	"Internal error"	"Debug message ring buffer: write file error."	

Source	Code	Type	Description	Possible cause
Frontpanel	2056	"Internal error"	"Debug message ring buffer: flush file error."	
Frontpanel	2057	"Internal error"	"Debug message ring buffer: unlink file error."	
Frontpanel	2058	"Internal error"	"Debug message system: print error failed."	
Frontpanel	2059	"Internal error"	"Debug message system: print output failed."	
Frontpanel	2060	"Internal error"	"Debug: cannot get core limit."	
Frontpanel	2061	"Internal error"	"Debug: cannot set core limit."	
Frontpanel	2062	"Internal error"	"Debug: cannot initialize mutex attributes."	
Frontpanel	2063	"Internal error"	"Debug: cannot set mutex attributes."	
Frontpanel	2064	"Internal error"	"Debug: cannot initialize mutex."	
Frontpanel	2065	"Internal error"	"Debug: cannot destroy mutex."	
Frontpanel	2066	"Internal error"	"Debug: cannot lock mutex."	
Frontpanel	2067	"Internal error"	"Debug: cannot unlock mutex."	
Frontpanel	2068	"Internal error"	"Debug: cannot allocate debug message system."	
Frontpanel	2069	"Internal error"	"Debug: cannot allocate debug message ring buffer."	
Frontpanel	2070	"Internal error"	"Debug: cannot allocate debug message file."	
Frontpanel	2071	"Internal error"	"Timer: cannot initialize mutex attributes."	
Frontpanel	2072	"Internal error"	"Timer: cannot set mutex attributes."	
Frontpanel	2073	"Internal error"	"Timer: cannot initialize mutex."	
Frontpanel	2074	"Internal error"	"Timer: cannot destroy mutex."	
Frontpanel	2075	"Internal error"	"Timer: cannot lock mutex."	
Frontpanel	2076	"Internal error"	"Timer: cannot unlock mutex."	
Frontpanel	2077	"Internal error"	"Timer: cannot allocate mark."	
Frontpanel	2078	"Internal error"	"Timer: cannot get time."	
Frontpanel	2079	"Internal error"	"Timing: cannot initialize mutex attributes."	
Frontpanel	2080	"Internal error"	"Timing: cannot set mutex attributes."	
Frontpanel	2081	"Internal error"	"Timing: cannot initialize mutex."	
Frontpanel	2082	"Internal error"	"Timing: cannot destroy mutex."	
Frontpanel	2083	"Internal error"	"Timing: cannot lock mutex."	
Frontpanel	2084	"Internal error"	"Timing: cannot unlock mutex."	
Frontpanel	2085	"Internal error"	"Timing: cannot allocate timer."	
Frontpanel	2086	"Internal error"	"Timing: timer not found."	
Frontpanel	2087	"Internal error"	"Command response item: cannot get string of non string type."	
Frontpanel	2088	"Internal error"	"Command response item: cannot get two items."	
Frontpanel	2089	"Internal error"	"Command response item: cannot get three items."	
Frontpanel	2090	"Internal error"	"Command response item: cannot get item."	

Source	Code	Type	Description	Possible cause
Frontpanel	2091	"Internal error"	"Command response item: cannot set null item."	
Frontpanel	2092	"Internal error"	"Command response item: cannot set item with null data."	
Frontpanel	2093	"Internal error"	"Command response item: cannot set null item vector."	
Frontpanel	2094	"Internal error"	"Command response item: cannot append item of different type."	
Frontpanel	2095	"Internal error"	"Command response item: item not compatible."	
Frontpanel	2096	"Internal error"	"Command response item: cannot serialize due small buffer."	
Frontpanel	2097	"Internal error"	"Command response item: cannot deserialize due small buffer."	
Frontpanel	2098	"Internal error"	"Command response vector: vector is empty."	
Frontpanel	2099	"Internal error"	"Command response vector: last response is null."	
Frontpanel	2100	"Internal error"	"Command response vector: response does not exist."	
Frontpanel	2101	"Internal error"	"Command response vector: cannot serialize due small buffer"	
Frontpanel	2102	"Internal error"	"Command response vector: cannot deserialize due response count mismatch."	
Frontpanel	2103	"Internal error"	"Command response vector: cannot deserialize due size mismatch."	
Frontpanel	2104	"Internal error"	"Command response: cannot set null response."	
Frontpanel	2105	"Internal error"	"Command response: cannot append null data."	
Frontpanel	2106	"Internal error"	"Command response: vector is empty."	
Frontpanel	2107	"Internal error"	"Command response: last item is null."	
Frontpanel	2108	"Internal error"	"Command response: item does not exist."	
Frontpanel	2109	"Internal error"	"Command response: cannot serialize due small buffer."	
Frontpanel	2110	"Internal error"	"Command response: cannot deserialize due item count mismatch."	
Frontpanel	2111	"Internal error"	"Command response: cannot deserialize due size mismatch."	
Frontpanel	2112	"Internal error"	"Interface response packet: cannot convert due small buffer."	
Frontpanel	2113	"Internal error"	"Interface response packet: cannot deserialize due size mismatch."	
Frontpanel	2114	"Internal error"	"DB9 GPIOs: owner not allowed."	
Frontpanel	2115	"Internal error"	"Signals: system call sigemptyset."	
Frontpanel	2116	"Internal error"	"Signals: system call sigaddset."	
Frontpanel	2117	"Internal error"	"Signals: system call pthread_sigmask."	
Frontpanel	2118	"Internal error"	"Signals: system call sigaction."	
Frontpanel	2119	"Internal error"	"Signals: cannot initialize destructor semaphore."	
Frontpanel	2120	"Internal error"	"Signals: cannot destroy destructor semaphore."	

Source	Code	Type	Description	Possible cause
Frontpanel	2121	"Internal error"	"Thread: cannot initialize mutex."	
Frontpanel	2122	"Internal error"	"Thread: cannot create thread."	
Frontpanel	2123	"Internal error"	"Thread: cannot cancel thread."	
Frontpanel	2124	"Internal error"	"Thread: cannot join thread."	
Frontpanel	2125	"Internal error"	"NVRAM: field is not double."	
Frontpanel	2126	"Internal error"	"NVRAM: field is not bool."	
Frontpanel	2127	"Internal error"	"NVRAM: field is not unsigned char."	
Frontpanel	2128	"Internal error"	"XML file: default document is null."	
Frontpanel	2129	"Internal error"	"XML file: cannot lock mutex."	
Frontpanel	2130	"Internal error"	"XML file: cannot unlock mutex."	
Frontpanel	2131	"Internal error"	"XML file: cannot lock file."	
Frontpanel	2132	"Internal error"	"XML file: cannot truncate file."	
Frontpanel	2133	"Internal error"	"XML file: cannot seek file."	
Frontpanel	2134	"Internal error"	"XML file: cannot write file."	
Frontpanel	2135	"Internal error"	"XML file: cannot flush file."	
Frontpanel	2136	"Internal error"	"XML file: cannot sync file."	
Frontpanel	2137	"Internal error"	"XML file: cannot initialize mutex attributes."	
Frontpanel	2138	"Internal error"	"XML file: cannot set mutex attribute."	
Frontpanel	2139	"Internal error"	"XML file: cannot initialize mutex."	
Frontpanel	2140	"Internal error"	"XML file: cannot unlink file."	
Frontpanel	2141	"Internal error"	"XML file: cannot convert to double."	
Frontpanel	2142	"Internal error"	"XML file: cannot convert to float."	
Frontpanel	2143	"Internal error"	"XML file: cannot convert to int."	
Frontpanel	2144	"Internal error"	"XML file: cannot convert to unsigned int."	
Frontpanel	2145	"Internal error"	"XML file: cannot convert to bool."	
Frontpanel	2146	"Internal error"	"XML file: cannot convert attribute."	
Frontpanel	2147	"Internal error"	"XML file: cannot convert attribute to bool"	
Frontpanel	2148	"Internal error"	"XML file: document is null."	
Frontpanel	2149	"Internal error"	"XML file: element is null."	
Frontpanel	2150	"Internal error"	"XML file: element data is null."	
Frontpanel	2151	"Internal error"	"XML file: attribute is null."	
Frontpanel	2152	"Internal error"	"XML file: attribute data is null."	
Frontpanel	2153	"Internal error"	"XML file: system call access failed."	
Frontpanel	2154	"Internal error"	"XML file: cannot rename file."	
Frontpanel	2155	"Internal error"	"XML file: cannot allocate document."	
Frontpanel	2156	"Internal error"	"XML file: CRC mismatch."	
Frontpanel	2157	"Internal error"	"XML file: version mismatch."	
Frontpanel	2158	"Internal error"	"XML file: cannot amend file."	
Frontpanel	2159	"Internal error"	"XML file: data out of range."	
Frontpanel	2160	"Internal error"	"XML file: cannot insert element."	

Source	Code	Type	Description	Possible cause
Frontpanel	2161	"Internal error"	"XML file: cannot clone element."	
Frontpanel	2162	"Internal error"	"CAN interface: cannot initialize mutex."	
Frontpanel	2163	"Internal error"	"CAN open stack: cannot initialize running mutex."	
Frontpanel	2164	"Internal error"	"CAN open stack: cannot initialize reset mutex."	
Frontpanel	2165	"Internal error"	"CAN open stack: cannot initialize CO mutex."	
Frontpanel	2166	"Internal error"	"CAN open stack: cannot initialize READ mutex."	
Frontpanel	2167	"Internal error"	"CAN open stack: cannot destroy CO mutex."	
Frontpanel	2168	"Internal error"	"CAN open stack: cannot destroy reset mutex."	
Frontpanel	2169	"Internal error"	"CAN open stack: cannot destroy running mutex."	
Frontpanel	2170	"Internal error"	"CAN open stack: cannot initialize CO."	
Frontpanel	2171	"Internal error"	"CAN open stack: cannot create timer thread."	
Frontpanel	2172	"Internal error"	"CAN open stack: cannot create RX thread."	
Frontpanel	2173	"Internal error"	"CAN open stack: cannot CAN socket."	
Frontpanel	2174	"Internal error"	"CAN open stack: cannot configure CAN socket."	
Frontpanel	2175	"Internal error"	"CAN open stack: cannot bind CAN socket."	
Frontpanel	2176	"Internal error"	"CAN open stack: cannot close CAN socket."	
Frontpanel	2177	"Internal error"	"CAN open stack: cannot write CAN socket."	
Frontpanel	2178	"Internal error"	"CAN open stack: write CAN socket size mismatch."	
Frontpanel	2179	"Internal error"	"CAN open stack: CAN socket not initialized."	
Frontpanel	2180	"Internal error"	"CAN open stack: cannot initialize CO timer semaphore."	
Frontpanel	2181	"Internal error"	"CAN open stack: cannot destroy CO timer semaphore."	
Frontpanel	2182	"Internal error"	"CAN main: cannot initialize background semaphore mutex."	
Frontpanel	2183	"Internal error"	"CAN main: cannot destroy background semaphore mutex."	
Frontpanel	2184	"Internal error"	"CAN main: cannot initialize background semaphore."	
Frontpanel	2185	"Internal error"	"CAN main: cannot destroy background semaphore."	
Frontpanel	2186	"Internal error"	"Discovery: cannot initialize daisy chain GPIO."	
Frontpanel	2187	"Internal error"	"Discovery: daisy chain GPIO not initialized."	
Frontpanel	2188	"Internal error"	"Discovery: cannot get processor types due small vector."	
Frontpanel	2189	"Internal error"	"Discovery: cannot get inverters due small vector."	
Frontpanel	2190	"Internal error"	"Discovery: cannot get primaries due small vector."	
Frontpanel	2191	"Internal error"	"Discovery: cannot allocate discovery."	

Source	Code	Type	Description	Possible cause
Frontpanel	2192	"Internal error"	"DSP commands: NMT."	
Frontpanel	2193	"Internal error"	"DSP commands: SDO download."	
Frontpanel	2194	"Internal error"	"DSP commands: SDO upload."	
Frontpanel	2195	"Internal error"	"DSP commands: LSS INCRS."	
Frontpanel	2196	"Internal error"	"DSP commands: LSS SSDC."	
Frontpanel	2197	"Internal error"	"DSP commands: LSS CNI."	
Frontpanel	2198	"Internal error"	"DSP commands: LSS SC."	
Frontpanel	2199	"Internal error"	"DSP commands: LSS FS."	
Frontpanel	2200	"Internal error"	"DSP commands: LSS PPSTFS."	
Frontpanel	2201	"Internal error"	"DSP commands: invalid node ID."	
Frontpanel	2202	"Internal error"	"DSP commands: invalid DSP type."	
Frontpanel	2203	"Internal error"	"DSP commands: invalid mapping number."	
Frontpanel	2204	"Internal error"	"DSP commands: invalid COB ID."	
Frontpanel	2205	"Internal error"	"DSP commands: invalid heart beat number."	
Frontpanel	2206	"Internal error"	"DSP commands: invalid tries number."	
Frontpanel	2207	"Internal error"	"DSP commands: read SDO buffer length."	
Frontpanel	2208	"Internal error"	"DSP commands: read bootloader DSP types."	
Frontpanel	2209	"Internal error"	"DSP commands: read bootloader state."	
Frontpanel	2210	"Internal error"	"DSP update commands: flag for update."	
Frontpanel	2211	"Internal error"	"DSP update commands: check device type."	
Frontpanel	2212	"Internal error"	"DSP update commands: check bootloader update state."	
Frontpanel	2213	"Internal error"	"DSP update commands: unlock flash CSM."	
Frontpanel	2214	"Internal error"	"DSP update commands: lock flash CSM."	
Frontpanel	2215	"Internal error"	"DSP update commands: erase flash sector."	
Frontpanel	2216	"Internal error"	"DSP update commands: write flash block."	
Frontpanel	2217	"Internal error"	"DSP update commands: firmware run."	
Frontpanel	2218	"Internal error"	"Condition comparison: unknown condition."	
Frontpanel	2219	"Internal error"	"Observer program: SCPI program not initialized."	
Frontpanel	2220	"Internal error"	"Command vector: invalid initialization order."	
Frontpanel	2221	"Internal error"	"Command vector: incomplete initialization."	
Frontpanel	2222	"Internal error"	"Observer vector: invalid initialization order."	
Frontpanel	2223	"Internal error"	"Observer vector: incomplete initialization."	
Frontpanel	2224	"Internal error"	"Operation file system: XML file not initialized."	
Frontpanel	2225	"Internal error"	"Operation SDO: cannot get node ID."	
Frontpanel	2226	"Internal error"	"Operation generic: command ID vector empty."	

Source	Code	Type	Description	Possible cause
Frontpanel	2227	"Internal error"	"Operation IEEE4882: long IDN string."	
Frontpanel	2228	"Internal error"	"Operation system: DB9 GPIOs invalid state."	
Frontpanel	2229	"Internal error"	"Operation source: DB9 GPIOs invalid state."	
Frontpanel	2230	"Internal error"	"Operation source: waveform invalid state."	
Frontpanel	2231	"Internal error"	"Operation source: XML configuration file not initialized."	
Frontpanel	2232	"Internal error"	"Operation source: XML program file not initialized."	
Frontpanel	2233	"Internal error"	"Operation simulation: invalid variable ID."	
Frontpanel	2234	"Internal error"	"Operation program: invalid transient status"	
Frontpanel	2235	"Internal error"	"Operation program: command not available."	
Frontpanel	2236	"Internal error"	"Firmware update manager: firmware up to date."	
Frontpanel	2237	"Internal error"	"DSP firmware update log: mutex lock error."	
Frontpanel	2238	"Internal error"	"DSP firmware update log: mutex unlock error."	
Frontpanel	2239	"Internal error"	"DSP firmware update log: error opening log file."	
Frontpanel	2240	"Internal error"	"DSP firmware update log: error flushing log file."	
Frontpanel	2241	"Internal error"	"DSP firmware update log: error closing log file."	
Frontpanel	2242	"Internal error"	"DSP firmware update log: error writing log file."	
Frontpanel	2243	"Internal error"	"DSP firmware update log: no file open to write."	
Frontpanel	2244	"Internal error"	"DSP firmware update log: class null."	
Frontpanel	2245	"Internal error"	"Application: invalid application command."	
Frontpanel	2246	"Internal error"	"Application: cannot initialize running mutex."	
Frontpanel	2247	"Internal error"	"Application: cannot initialize application mutex."	
Frontpanel	2248	"Internal error"	"Application: cannot create timer."	
Frontpanel	2249	"Internal error"	"Application: cannot configure timer."	
Frontpanel	2250	"Internal error"	"Application: cannot close timer."	
Frontpanel	2251	"Internal error"	"XML handler: cannot load XML."	
Frontpanel	2252	"Internal error"	"Application: cannot save XML."	
Frontpanel	2253	"Internal error"	"Avahi XML: folder does not exist."	
Frontpanel	2254	"Internal error"	"Avahi XML: file does not exist."	
Frontpanel	2255	"Internal error"	"Avahi XML: invalid field number."	
Frontpanel	2256	"Internal error"	"Network manager: thread not initialized."	
Frontpanel	2257	"Internal error"	"Network manager: invalid variable ID."	
Frontpanel	2258	"Internal error"	"Network manager: invalid configuration type."	
Frontpanel	2259	"Internal error"	"Network manager: netconfig call failed."	

Source	Code	Type	Description	Possible cause
Frontpanel	2260	"Internal error"	"Network manager: avahi call failed."	
Frontpanel	2261	"Internal error"	"Network manager: udhcp call failed."	
Frontpanel	2262	"Internal error"	"Network manager: netconfig field not found."	
Frontpanel	2263	"Internal error"	"Network manager: invalid service name."	
Frontpanel	2264	"Internal error"	"Network manager: avahi close process."	
Frontpanel	2265	"Internal error"	"External interface: invalid socket path."	
Frontpanel	2266	"Internal error"	"External interface: cannot create from socket."	
Frontpanel	2267	"Internal error"	"External interface: cannot bind from socket."	
Frontpanel	2268	"Internal error"	"External interface: cannot listen from socket."	
Frontpanel	2269	"Internal error"	"External interface: cannot create to socket."	
Frontpanel	2270	"Internal error"	"External interface: cannot bind to socket."	
Frontpanel	2271	"Internal error"	"External interface: cannot listen to socket."	
Frontpanel	2272	"Internal error"	"External interface: cannot initialize to socket mutex."	
Frontpanel	2273	"Internal error"	"External interface: cannot allocate thread."	
Frontpanel	2274	"Internal error"	"External interface: invalid packet type."	
Frontpanel	2275	"Internal error"	"External interface: invalid response type."	
Frontpanel	2276	"Internal error"	"XML SCPI program file: buffer is null."	
Frontpanel	2277	"Internal error"	"XML SCPI program file: buffer is small."	
Frontpanel	2278	"Internal error"	"Program is undefined."	
Frontpanel	2279	"Internal error"	"XML SCPI program file: element is null."	
Frontpanel	2280	"Internal error"	"EEPROM: call failed."	
Frontpanel	2281	"Internal error"	"EEPROM: field not found."	
Frontpanel	2282	"Internal error"	"Memories: invalid folder."	
Frontpanel	2283	"Internal error"	"Memories: invalid name."	
Frontpanel	2284	"Internal error"	"XML access file: invalid IP."	
Frontpanel	2285	"Internal error"	"XML access file: invalid alias size."	
Frontpanel	2286	"Internal error"	"XML access file: cannot convert to bool."	
Frontpanel	2287	"Internal error"	"XML access file: invalid tag."	
Frontpanel	2288	"Internal error"	"Temperature: cannot open file."	
Frontpanel	2289	"Internal error"	"Temperature: file not opened."	
Frontpanel	2290	"Internal error"	"Temperature: cannot seek file."	
Frontpanel	2291	"Internal error"	"Temperature: cannot read file."	
Frontpanel	2292	"Internal error"	"Remote: DB9 GPIO not initialized."	
Frontpanel	2293	"Internal error"	"Remote: cannot open UIO."	
Frontpanel	2294	"Internal error"	"Remote: cannot write UIO."	
Frontpanel	2295	"Internal error"	"Interface vector: cannot initialize mutex attributes."	
Frontpanel	2296	"Internal error"	"Interface vector: cannot set mutex attributes."	

Source	Code	Type	Description	Possible cause
Frontpanel	2297	"Internal error"	"Interface vector: cannot initialize mutex."	
Frontpanel	2298	"Internal error"	"Interface vector: cannot allocate VXI interface."	
Frontpanel	2299	"Internal error"	"Interface vector: cannot lock mutex."	
Frontpanel	2300	"Internal error"	"Interface vector: cannot unlock mutex."	
Frontpanel	2301	"Internal error"	"SCPI program: destination program cannot be manual mode."	
Frontpanel	2302	"Internal error"	"SCPI program: invalid define string."	
Frontpanel	2303	"Internal error"	"SCPI program: missing voltage A."	
Frontpanel	2304	"Internal error"	"SCPI program: missing voltage B."	
Frontpanel	2305	"Internal error"	"Cannot get waveform field."	
Frontpanel	2306	"Internal error"	"Cannot delete waveform in use."	
Frontpanel	2307	"Internal error"	"Waveform #1 cannot be deleted or modified."	
Frontpanel	2308	"Internal error"	"Sequential interface: cannot initialize command executed semaphore."	
Frontpanel	2309	"Internal error"	"Sequential interface: cannot initialize execute command semaphore."	
Frontpanel	2310	"Internal error"	"Sequential interface: cannot initialize pending commands mutex."	
Frontpanel	2311	"Internal error"	"IEEE488.2 status: cannot initialize mutex."	
Frontpanel	2312	"Internal error"	"IEEE488.2 status: item does not exist."	
Frontpanel	2313	"Internal error"	"Fault manager: MDO not received."	
Frontpanel	2314	"Internal error"	"Measurement logger manager: cannot write file."	
Frontpanel	2315	"Internal error"	"Synchronization: cannot initialize operation complete mutex."	
Frontpanel	2316	"Internal error"	"Synchronization: cannot initialize operation complete mutex attributes."	
Frontpanel	2317	"Internal error"	"Synchronization: cannot set operation complete mutex attributes."	
Frontpanel	2318	"Internal error"	"Synchronization: cannot initialize operation complete condition variable."	
Frontpanel	2319	"Internal error"	"SCPI parser: cannot initialize mutex."	
Frontpanel	2320	"Internal error"	"SCPI parser: cannot lock mutex."	
Frontpanel	2321	"Internal error"	"SCPI parser: cannot unlock mutex."	
Frontpanel	113	"Internal warning"	"Missed second heartbeat."	
Frontpanel	114	"Internal warning"	"Missed first heartbeat."	
Frontpanel	123	"Internal warning"	"Warning: input voltage in EEPROM does not match the Primary DSP. Using DSP value."	
Frontpanel	0	"Success"	"No error"	
Inverter	265	"Fault"	"Inverter gate driver fault."	
Inverter	266	"Fault"	"Internal bias supply fault."	
Inverter	267	"Fault"	"No waveform loaded. Load waveform before enabling arbitrary waveform mode."	
Inverter	268	"Fault"	"Exceeded RMS current limit."	
Inverter	269	"Fault"	"Exceeded active power limit."	

Source	Code	Type	Description	Possible cause
Inverter	270	"Fault"	"Exceeded apparent power limit."	
Inverter	271	"Fault"	"Internal SCIA communication error."	
Inverter	272	"Fault"	"Internal McBSP communication CRC error."	
Inverter	273	"Fault"	"Inverter current negative peak protection."	
Inverter	274	"Fault"	"Inverter current positive peak protection."	
Inverter	275	"Fault"	"DC bus voltage minimum limit exceeded."	
Inverter	276	"Fault"	"DC bus voltage maximum limit exceeded."	
Inverter	277	"Fault"	"Temperature protection	Mmaximum limit
Inverter	278	"Fault"	"Temperature protection	Minimum limit
Inverter	279	"Fault"	"Output relay voltage protection	Minimum limit
Inverter	280	"Fault"	"Output relay voltage protection	Maximum limit
Inverter	281	"Fault"	"Output terminals common mode voltage protection	Minimum limit
Inverter	282	"Fault"	"Output terminals common mode voltage protection	Maximum limit
Inverter	283	"Fault"	"Inductor current RMS protection	Exceeded maximum limit for too long
Inverter	284	"Fault"	"Inductor current DC protection	Exceeded maximum limit for too long
Inverter	285	"Fault"	"Global fault input signal detected."	
Inverter	286	"Fault"	"Fan under voltage protection."	
Inverter	287	"Fault"	"Inductor current cycle-by-cycle protection trip limit."	
Inverter	288	"Fault"	"Fan current consumption is abnormal	Fan may be blocked
Inverter	292	"Fault"	"Output current has too much high frequency content	Possible oscillation. RQ monitor fault
Inverter	293	"Fault"	"Controller missed heartbeats from master front panel."	
Inverter	294	"Fault"	"Output over-voltage protection."	
Inverter	296	"Fault"	"Output current peak protection."	
Inverter	297	"Fault"	"Remote voltage sensing fault."	
Inverter	298	"Fault"	"Internal capacitors over-current protection."	
Inverter	299	"Fault"	"Internal bus over-voltage protection. Possible regenerative load."	
Inverter	300	"Fault"	"CSC loop has saturated"	
Inverter	301	"Fault"	"Output current overload. RMS current exceeded limit."	
Inverter	302	"Fault"	"Internal muxed ADC protection fault."	
Inverter	303	"Fault"	"Internal fan current regulation fault."	
Inverter	304	"Fault"	"Parallel units model mismatch."	
Inverter	289	"Internal fault"	"Hardware revision does not match expected by firmware. Firmware must be reloaded."	

Source	Code	Type	Description	Possible cause
Inverter	290	"Internal fault"	"Invalid node ID. Run unit discovery to recover."	
Inverter	291	"Internal fault"	"Incorrect DSP type detected. Cycle-power to re-try."	
Inverter	295	"Internal fault"	"Invalid constants loaded from EEPROM."	
Inverter	326	"Internal fault"	"Controller is not in operational node."	
Inverter	327	"Internal fault"	"Missing controller node."	
Inverter	328	"Internal fault"	"Cannot read fault information."	
Primary	200	"Fault"	"LLC primary/auxiliary current peak limit exceeded."	
Primary	201	"Fault"	"LLC/PFC gate driver fault or hardware OVP."	
Primary	202	"Fault"	"Controller missed heartbeats from master front panel."	
Primary	203	"Fault"	"LLC primary current average limit exceeded."	
Primary	204	"Fault"	"LLC auxiliary current average limit exceeded."	
Primary	205	"Fault"	"PFC current peak limit exceeded."	
Primary	206	"Fault"	"PFC DC bus voltage limit exceeded."	
Primary	207	"Fault"	"Gate driver fault"	Input buck converter
Primary	208	"Fault"	"Input buck switching time."	
Primary	209	"Fault"	"AC input current exceeded RMS limit for too long."	
Primary	210	"Fault"	"Unbalanced current in PFC boost converters."	
Primary	211	"Fault"	"PFC efficiency protection."	
Primary	212	"Fault"	"AC input: voltage is below minimum."	
Primary	213	"Fault"	"AC input: missing phase."	
Primary	214	"Fault"	"PFC DC bus voltage regulation lost."	
Primary	215	"Fault"	"PFC DC bus voltage limit exceeded. CLA OVP Trip"	
Primary	216	"Fault"	"Temperature 1 protection (input stage)"	Exceeded maximum limit
Primary	217	"Fault"	"Temperature 1 protection (input stage)"	Exceeded minimum limit
Primary	218	"Fault"	"Temperature 2 protection (PFC/LLC)"	Exceeded maximum limit
Primary	219	"Fault"	"Temperature 2 protection (PFC/LLC)"	Exceeded minimum limit
Primary	220	"Fault"	"Temperature 3 protection (PFC/LLC)"	Exceeded maximum limit
Primary	221	"Fault"	"Temperature 3 protection (PFC/LLC) exceeded minimum limit."	
Primary	222	"Fault"	"Temperature 4 protection (main transformer)"	Exceeded maximum limit
Primary	223	"Fault"	"Temperature 4 protection (main transformer)"	Exceeded minimum limit
Primary	224	"Fault"	"Internal bias supply fault."	
Primary	230	"Fault"	"PFC output current peak protection."	

Source	Code	Type	Description	Possible cause
Primary	231	"Fault"	"PFC output current slow protection"	
Primary	232	"Fault"	"AC input: voltage is above maximum."	
Primary	234	"Fault"	"Firmware task execution error."	
Primary	225	"Internal fault"	"Global fault input signal detected."	
Primary	226	"Internal fault"	"Hardware does not match input voltage setting."	
Primary	227	"Internal fault"	"Primary capacitor board not detected."	
Primary	228	"Internal fault"	"Invalid node ID. Run unit discovery to recover."	
Primary	229	"Internal fault"	"Incorrect DSP type detected. Cycle-power to re-try."	
Primary	233	"Internal fault"	"Invalid constants loaded from EEPROM."	
Primary	261	"Internal fault"	"Controller is not in operational node."	
Primary	262	"Internal fault"	"Missing controller node."	
Primary	263	"Internal fault"	"Cannot read fault information."	
IO board	399	"Fault"	"Transformer coupling / series connection circuits hardware fault."	
IO board	400	"Fault"	"Transformer coupling / series connection circuits not detected."	
IO board	401	"Fault"	"Remote inhibit was issued from remote interface."	
IO board	393	"Internal fault"	"Global fault detected."	
IO board	394	"Internal fault"	"Internal board fault."	
IO board	395	"Internal fault"	"Invalid node ID. Run unit discovery to recover."	
IO board	396	"Internal fault"	"Incorrect DSP type detected. Cycle-power to re-try."	
IO board	397	"Internal fault"	"Invalid constants loaded from EEPROM."	
IO board	398	"Internal fault"	"Controller is not in operational node."	
IO board	454	"Internal fault"	"Controller is not in operational node."	
IO board	455	"Internal fault"	"Missing controller node."	
IO board	456	"Internal fault"	"Cannot read fault information."	

Table 12-1: Warnings and Error Messages Listing

13 Service and Maintenance

13.1 Warnings



CAUTION

THIS EQUIPMENT CONTAINS HIGH ENERGY, LOW IMPEDANCE CIRCUITS! LETHAL POTENTIALS ARE CONTAINED WITHIN THIS UNIT.

CARE MUST BE EXERCISED WHEN SERVICING THIS EQUIPMENT IN ORDER TO PREVENT SERIOUS SERVICE PERSONNEL INJURY OR EQUIPMENT DAMAGE.

OBSERVE THE FOLLOWING WHEN SERVICE OR MAINTENANCE ARE REQUIRED:

- 1. REMOVE ALL JEWELRY FROM ARMS AND NECK WHEN SERVICING THIS EQUIPMENT. THIS PREVENTS THE POSSIBILITY OF SHORTING THROUGH THE JEWELRY AND CAUSING BURNS TO SERVICE PERSONNEL.**
- 2. WEAR SAFETY GLASSES WHEN SERVICING THIS EQUIPMENT TO PREVENT EYE INJURY DUE TO FLYING PARTICLES CAUSED BY ACCIDENTAL SHORT CIRCUIT CONDITIONS.**
- 3. DO NOT REMOVE ANY PANEL OR COVER WITHOUT FIRST REMOVING THE INPUT SERVICE BY OPENING ALL CIRCUIT BREAKERS.**
- 4. DO NOT REMOVE ANY PANEL OR COVER WITHOUT FIRST WAITING 20 MINUTES FOR ALL INTERNAL CHARGES TO DISSIPATE TO A SAFE LEVEL.**
- 5. SERVICE OTHER THAN EXTERNAL CLEANING SHOULD BE REFERRED TO PERSONNEL AUTHORIZED BY THE FACTORY TO SERVICE THIS EQUIPMENT.**



AVERTISSEMENT

CET ÉQUIPEMENT CONTIENT DES CIRCUITS À HAUTE ÉNERGIE ET À BASSE IMPÉDANCE ! LES POTENTIELS MORTELS SONT CONTENUS DANS CETTE UNITÉ.

IL FAUT FAIRE ATTENTION LORS DE L'ENTRETIEN DE CET ÉQUIPEMENT AFIN D'ÉVITER DES BLESSURES GRAVES DU PERSONNEL D'ENTRETIEN OU DES DOMMAGES À L'ÉQUIPEMENT.

OBSERVEZ CE QUI SUIT LORSQUE L'ENTRETIEN OU LA MAINTENANCE SONT NÉCESSAIRES :

- 1. RETIREZ TOUS LES BIJOUX DES BRAS ET DU COU LORS DE L'ENTRETIEN DE CET ÉQUIPEMENT. CELA EMPÊCHE LA POSSIBILITÉ DE COURT-CIRCUIT À TRAVERS LES BIJOUX ET DE CAUSER DES BRÛLURES AU PERSONNEL D'ENTRETIEN.**
- 2. PORTEZ DES LUNETTES DE SÉCURITÉ LORS DE L'ENTRETIEN DE CET ÉQUIPEMENT AFIN D'ÉVITER LES BLESSURES OCULAIRES DUES AUX PARTICULES VOLANTES CAUSÉES PAR DES CONDITIONS DE COURT-CIRCUIT ACCIDENTELS.**
- 3. NE RETIREZ AUCUN PANNEAU OU COUVERCLE SANS D'ABORD RETIRER LE SERVICE D'ENTRÉE EN OUVRANT TOUS LES DISJONCTEURS.**
- 4. NE RETIREZ AUCUN PANNEAU OU COUVERCLE SANS AVOIR D'ABORD ATTENDU 20 MINUTES QUE TOUTES LES CHARGES INTERNES SE DISSIPENT À UN NIVEAU SÛR.**

5 TOUTE RÉPARATION AUTRE QUE LE NETTOYAGE EXTERNE DOIT ÊTRE RÉFÉRÉE AU PERSONNEL AUTORISÉ PAR L'USINE POUR RÉPARER CET ÉQUIPEMENT.

13.2 Authorized Service Centers

There are **NO** end-user serviceable parts in this product. In case of a problem or malfunction, **DO NOT ATTEMPT TO REPAIR!** Instead, contact one of Pacific Power Source's authorized service centers or your local Pacific Power Source distributor. For a list of authorized service centers, refer to section 1, "Contact Information".

14 ModBus TCP Server / Slave Interface

14.1 TCP ModBus Interface

The ModBus TCP Server/Slave Interface provides a means to communicate with industrial bus protocols. This is a register based interface so no SCPI programming commands apply. Instead of sending commands, the user can write to specific register addresses to change various settings and read from other registers to obtain readings such as measurements or settings.

Gateway devices are available from third parties to connect to other bus protocols.

<https://www.anybus.com/products/gateway-index?Network-Interface-1=Modbus-TCP-Client/Master>

These gateways perform an intelligent protocol translation that allows devices and control systems using different protocols to communicate with each other seamlessly.

To use this interface, the user needs to reference the register addresses provided in the next section.

14.2 Modbus TCP Register Tables

The following tables apply to ADF, AFX, AZX, LMX and LSX Series power sources models. Some functions may not be supported on specific model series depending on supported modes of operation and feature sets.

Note: The information contained in the table below is available for download in MS Excel file [modbustcp-registers.xlsx](#) at the following link under 'documentation':

https://github.com/PPST-Inc/ModbusTCP_Examples

Modbus App

	Modbus address (dec)	Modbus address (hex)	Read coils	Read holding registers	Read input registers (0x06)	Write single coil (0x05)	Write single register (0x06)	Write multiple registers (0x10)	Description	Access	Data type	Data length in bytes	Number of registers	Data	Example
Modbus Interface	0	0000													
	1	0001			x				Modbus Ver	R	uint(16)	2	1		
	2	0002			x				Modbus Info	R	uint(16)	2	1		
Measurements	1000	03E8			x				Frequency	R	float	4	2	FP IEEE754	60
	1002	03EA			x				Output A frequency	R	float	4	2	FP IEEE754	
	1004	03EC			x				Output B frequency	R	float	4	2	FP IEEE754	
	1006	03EE			x				Output C frequency	R	float	4	2	FP IEEE754	

Modbus App

Modbus address (dec)	Modbus address (hex)	Read coils	Read holding registers	Read input registers (0x06)	Write single coil (0x05)	Write single register (0x06)	Write multiple registers (0x10)	Description	Access	Data type	Data length in bytes	Number of registers	Data	Example
1008	03F0			x				Voltage line to line ACDC	R	float	4	2	FP IEEEE754	
1010	03F2			x				Output A voltage line to line ACDC	R	float	4	2	FP IEEEE754	
1012	03F4			x				Output B voltage line to line ACDC	R	float	4	2	FP IEEEE754	
1014	03F6			x				Output C voltage line to line ACDC	R	float	4	2	FP IEEEE754	
1016	03F8			x				Voltage line to line AC	R	float	4	2	FP IEEEE754	
1018	03FA			x				Output A voltage line to line AC	R	float	4	2	FP IEEEE754	
1020	03FC			x				Output B voltage line to line AC	R	float	4	2	FP IEEEE754	
1022	03FE			x				Output C voltage line to line AC	R	float	4	2	FP IEEEE754	
1024	0400			x				Voltage line to line DC	R	float	4	2	FP IEEEE754	
1026	0402			x				Output A voltage line to line DC	R	float	4	2	FP IEEEE754	
1028	0404			x				Output B voltage line to line DC	R	float	4	2	FP IEEEE754	
1030	0406			x				Output C voltage line to line DC	R	float	4	2	FP IEEEE754	
1032	0408			x				Voltage ACDC	R	float	4	2	FP IEEEE754	
1034	040A			x				Output A voltage ACDC	R	float	4	2	FP IEEEE754	
1036	040C			x				Output B voltage ACDC	R	float	4	2	FP IEEEE754	
1038	040E			x				Output C voltage ACDC	R	float	4	2	FP IEEEE754	
1040	0410			x				Voltage AC	R	float	4	2	FP IEEEE754	
1042	0412			x				Output A voltage AC	R	float	4	2	FP IEEEE754	

Modbus App

Modbus address (dec)	Modbus address (hex)	Read coils	Read holding registers	Read input registers (0x06)	Write single coil (0x05)	Write single register (0x06)	Write multiple registers (0x10)	Description	Access	Data type	Data length in bytes	Number of registers	Data	Example
1044	0414			x				Output B voltage AC	R	float	4	2	FP IEEEE754	
1046	0416			x				Output C voltage AC	R	float	4	2	FP IEEEE754	
1048	0418			x				Voltage DC	R	float	4	2	FP IEEEE754	
1050	041A			x				Output A voltage DC	R	float	4	2	FP IEEEE754	
1052	041C			x				Output B voltage DC	R	float	4	2	FP IEEEE754	
1054	041E			x				Output C voltage DC	R	float	4	2	FP IEEEE754	
1056	0420			x				Current ACDC	R	float	4	2	FP IEEEE754	
1058	0422			x				Output A current ACDC	R	float	4	2	FP IEEEE754	
1060	0424			x				Output B current ACDC	R	float	4	2	FP IEEEE754	
1062	0426			x				Output C current ACDC	R	float	4	2	FP IEEEE754	
1064	0428			x				Current DC	R	float	4	2	FP IEEEE754	
1066	042A			x				Output A current DC	R	float	4	2	FP IEEEE754	
1068	042C			x				Output B current DC	R	float	4	2	FP IEEEE754	
1070	042E			x				Output C current DC	R	float	4	2	FP IEEEE754	
1072	0430			x				Active power	R	float	4	2	FP IEEEE754	
1074	0432			x				Output A active power	R	float	4	2	FP IEEEE754	
1076	0434			x				Output B active power	R	float	4	2	FP IEEEE754	
1078	0436			x				Output C active power	R	float	4	2	FP IEEEE754	
1080	0438			x				Apparent power	R	float	4	2	FP IEEEE754	
1082	043A			x				Output A apparent power	R	float	4	2	FP IEEEE754	
1084	043C			x				Output B apparent power	R	float	4	2	FP IEEEE754	
1086	043E			x				Output C apparent power	R	float	4	2	FP IEEEE754	
1088	0440			x				Peak current	R	float	4	2	FP IEEEE754	

Modbus App

Modbus address (dec)	Modbus address (hex)	Read coils	Read holding registers	Read input registers (0x06)	Write single coil (0x05)	Write single register (0x06)	Write multiple registers (0x10)	Description	Access	Data type	Data length in bytes	Number of registers	Data	Example
1090	0442			x				Output A peak current	R	float	4	2	FP IEEE754	
1092	0444			x				Output B peak current	R	float	4	2	FP IEEE754	
1094	0446			x				Output C peak current	R	float	4	2	FP IEEE754	
1096	0448			x				Power factor	R	float	4	2	FP IEEE754	
1098	044A			x				Output A power factor	R	float	4	2	FP IEEE754	
1100	044C			x				Output B power factor	R	float	4	2	FP IEEE754	
1102	044E			x				Output C power factor	R	float	4	2	FP IEEE754	
1104	0450			x				Crest factor	R	float	4	2	FP IEEE754	
1106	0452			x				Output A crest factor	R	float	4	2	FP IEEE754	
1108	0454			x				Output B crest factor	R	float	4	2	FP IEEE754	
1110	0456			x				Output C crest factor	R	float	4	2	FP IEEE754	
1112	0458			x				Peak current recorded	R	float	4	2	FP IEEE754	
1114	045A			x				Output A peak current recorded	R	float	4	2	FP IEEE754	
1116	045C			x				Output B peak current recorded	R	float	4	2	FP IEEE754	
1118	045E			x				Output C peak current recorded	R	float	4	2	FP IEEE754	
1120	0460			x				Voltage thd	R	float	4	2	FP IEEE754	
1122	0462			x				Output A voltage thd	R	float	4	2	FP IEEE754	
1124	0464			x				Output B voltage thd	R	float	4	2	FP IEEE754	
1126	0466			x				Output C voltage thd	R	float	4	2	FP IEEE754	
1128	0468			x				Current thd	R	float	4	2	FP IEEE754	
1130	046A			x				Output A current thd	R	float	4	2	FP IEEE754	
1132	046C			x				Output B current thd	R	float	4	2	FP IEEE754	
1134	046E			x				Output C current thd	R	float	4	2	FP IEEE754	

Modbus App

Modbus address (dec)	Modbus address (hex)	Read coils	Read holding registers	Read input registers (0x06)	Write single coil (0x05)	Write single register (0x06)	Write multiple registers (0x10)	Description	Access	Data type	Data length in bytes	Number of registers	Data	Example
1136	0470			x				Power factor angle	R	float	4	2	FP IEEEE754	
1138	0472			x				Output A power factor angle	R	float	4	2	FP IEEEE754	
1140	0474			x				Output B power factor angle	R	float	4	2	FP IEEEE754	
1142	0476			x				Output C power factor angle	R	float	4	2	FP IEEEE754	
1144	0478			x				Displacement factor	R	float	4	2	FP IEEEE754	
1146	047A			x				Output A displacement factor	R	float	4	2	FP IEEEE754	
1148	047C			x				Output B displacement factor	R	float	4	2	FP IEEEE754	
1150	047E			x				Output C displacement factor	R	float	4	2	FP IEEEE754	
1152	0480			x				Distortion factor	R	float	4	2	FP IEEEE754	
1154	0482			x				Output A distortion factor	R	float	4	2	FP IEEEE754	
1156	0484			x				Output B distortion factor	R	float	4	2	FP IEEEE754	
1158	0486			x				Output C distortion factor	R	float	4	2	FP IEEEE754	
1160	0488			x				Kilowatt hour	R	float	4	2	FP IEEEE754	
1162	048A			x				Output A kilowatt hour	R	float	4	2	FP IEEEE754	
1164	048C			x				Output B kilowatt hour	R	float	4	2	FP IEEEE754	
1166	048E			x				Output C kilowatt hour	R	float	4	2	FP IEEEE754	
1168	0490			x				Kilowatt hour elapsed time	R	float	4	2	FP IEEEE754	
1170	0492			x				Output A kilowatt hour elapsed time	R	float	4	2	FP IEEEE754	

Modbus App

Modbus address (dec)	Modbus address (hex)	Read coils	Read holding registers	Read input registers (0x06)	Write single coil (0x05)	Write single register (0x06)	Write multiple registers (0x10)	Description	Access	Data type	Data length in bytes	Number of registers	Data	Example
1172	0494			x				Output B kilowatt hour elapsed time	R	float	4	2	FP IEEE754	
1174	0496			x				Output C kilowatt hour elapsed time	R	float	4	2	FP IEEE754	
2800	0AF0	x			x			Reset KWH	RW	bool			Coils : Kreset	ON=reset , self clear
2801	0AF1	x			x			Enable KWH	RW	bool			Coils : Kwhenable	ON=enable, OFF=disable

Setpoints Program	3000	0BB8						Program frequency	RW	float	4	2	FP IEEE754	
	3002	0BBA						Program frequency A	RW	float	4	2	FP IEEE754	
	3004	0BBC						Program frequency B	RW	float	4	2	FP IEEE754	
	3006	0BBE						Program frequency C	RW	float	4	2	FP IEEE754	
	3008	0BC0						Program voltage AC	RW	float	4	2	FP IEEE754	Value=V ALUE if all set, Value=0 if else
	3010	0BC2						Program voltage AC output A	RW	float	4	2	FP IEEE754	
	3012	0BC4						Program voltage AC output B	RW	float	4	2	FP IEEE754	
	3014	0BC6						Program voltage AC output C	RW	float	4	2	FP IEEE754	
	3016	0BC8						Program voltage DC	RW	float	4	2	FP IEEE754	Value=V ALUE if all set, Value=0 if else
	3018	0BCA						Program voltage DC output A	RW	float	4	2	FP IEEE754	

Modbus App

Modbus address (dec)	Modbus address (hex)	Read coils	Read holding registers	Read input registers (0x06)	Write single coil (0x05)	Write single register (0x06)	Write multiple registers (0x10)	Description	Access	Data type	Data length in bytes	Number of registers	Data	Example
3020	0BCC							Program voltage DC output B	RW	float	4	2	FP IEEE754	
3022	0BCE							Program voltage DC output C	RW	float	4	2	FP IEEE754	
3024	0BD0							Power limit	RW	float	4	2	FP IEEE754	Value=V ALUE if all set, Value=0 if else
3026	0BD2							Power limit output A	RW	float	4	2	FP IEEE754	
3028	0BD4							Power limit output B	RW	float	4	2	FP IEEE754	
3030	0BD6							Power limit output C	RW	float	4	2	FP IEEE754	
3032	0BD8							Current limit ABC	RW	float	4	2	FP IEEE754	Value=V ALUE if all set, Value=0 if else
3034	0BDA							Current limit output A	RW	float	4	2	FP IEEE754	
3036	0BDC							Current limit output B	RW	float	4	2	FP IEEE754	
3038	0BDE							Current limit output C	RW	float	4	2	FP IEEE754	
3040	0BE0							KVA Limit	RW	float	4	2	FP IEEE754	Value=V ALUE if all set, Value=0 if else
3042	0BE2							KVA Limit output A	RW	float	4	2	FP IEEE754	
3044	0BE4							KVA Limit output B	RW	float	4	2	FP IEEE754	
3046	0BE6							KVA Limit output C	RW	float	4	2	FP IEEE754	
3048	0BE8							Phase offset output B	RW	float	4	2	FP IEEE754	
3050	0BEA							Phase offset output C	RW	float	4	2	FP IEEE754	
4000	0FA0	x			x			Enable output	RW	bool			Coils: Output	ON=enab le,

Modbus App

Modbus address (dec)	Modbus address (hex)	Read coils	Read holding registers	Read input registers (0x06)	Write single coil (0x05)	Write single register (0x06)	Write multiple registers (0x10)	Description	Access	Data type	Data length in bytes	Number of registers	Data	Example
														OFF=disable
4001	0FA1	x			x			Enable output A	RW	bool			Coils: Output	ON=enable, OFF=disable
4002	0FA2	x			x			Enable output B	RW	bool			Coils: Output	ON=enable, OFF=disable
4003	0FA3	x			x			Enable output C	RW	bool			Coils: Output	ON=enable, OFF=disable

5000	1388	x			x			RMS Current protection	RW	bool				
5001	1389	x			x			Output A RMS Current protection	RW	bool				
5002	138A	x			x			Output B RMS Current protection	RW	bool				
5003	138B	x			x			Output C RMS Current protection	RW	bool				
5004	138C	x			x			RMS Power protection	RW	bool				
5005	138D	x			x			Output A RMS Power protection	RW	bool				
5006	138E	x			x			Output B RMS Power protection	RW	bool				
5007	138F	x			x			Output C RMS Power protection	RW	bool				
5008	1390	x			x			Peak current protection	RW	bool				
5009	1391	x			x			Output A Peak current protection	RW	bool				

Modbus App

Modbus address (dec)	Modbus address (hex)	Read coils	Read holding registers	Read input registers (0x06)	Write single coil (0x05)	Write single register (0x06)	Write multiple registers (0x10)	Description	Access	Data type	Data length in bytes	Number of registers	Data	Example
5010	1392	x			x			Output B Peak current protection	RW	bool				
5011	1393	x			x			Output C Peak current protection	RW	bool				
5012	1394	x			x			Peak voltage protection	RW	bool				
5013	1395	x			x			Output A Peak voltage protection	RW	bool				
5014	1396	x			x			Output B Peak voltage protection	RW	bool				
5015	1397	x			x			Output C Peak voltage protection	RW	bool				
5024	13A0							Current level	RW	float	4	2	FP IEEE754	
5026	13A2							Output A Current level	RW	float	4	2	FP IEEE754	
5028	13A4							Output B Current level	RW	float	4	2	FP IEEE754	
5030	13A6							Output C Current level	RW	float	4	2	FP IEEE754	
5032	13A8							Power level	RW	float	4	2	FP IEEE754	
5034	13AA							Output A Power level	RW	float	4	2	FP IEEE754	
5036	13AC							Output B Power level	RW	float	4	2	FP IEEE754	
5038	13AE							Output C Power level	RW	float	4	2	FP IEEE754	
5040	13B0							KVA Level	RW	float	4	2	FP IEEE754	
5042	13B2							Output A KVA Level	RW	float	4	2	FP IEEE754	
5044	13B4							Output B KVA Level	RW	float	4	2	FP IEEE754	
5046	13B6							Output C KVA Level	RW	float	4	2	FP IEEE754	
5048	13B8							Trip time	RW	float	4	2	FP IEEE754	minimum step of 0.1 seconds
5050	13BA							Output A Trip time	RW	float	4	2	FP IEEE754	

Modbus App

Modbus address (dec)	Modbus address (hex)	Read coils	Read holding registers	Read input registers (0x06)	Write single coil (0x05)	Write single register (0x06)	Write multiple registers (0x10)	Description	Access	Data type	Data length in bytes	Number of registers	Data	Example
5052	13BC							Output B Trip time	RW	float	4	2	FP IEEEE754	
5054	13BE							Output C Trip time	RW	float	4	2	FP IEEEE754	
5056	13C0							Peak current limit	RW	float	4	2	FP IEEEE754	
5058	13C2							Output A Peak current limit	RW	float	4	2	FP IEEEE754	
5060	13C4							Output B Peak current limit	RW	float	4	2	FP IEEEE754	
5062	13C6							Output C Peak current limit	RW	float	4	2	FP IEEEE754	
5064	13C8							Peak current protection level	RW	float	4	2	FP IEEEE754	
5066	13CA							Output A Peak current protection level	RW	float	4	2	FP IEEEE754	
5068	13CC							Output B Peak current protection level	RW	float	4	2	FP IEEEE754	
5070	13CE							Output C Peak current protection level	RW	float	4	2	FP IEEEE754	
5072	13D0							Peak voltage protection margin	RW	float	4	2	FP IEEEE754	
5074	13D2							Output A Peak voltage protection margin	RW	float	4	2	FP IEEEE754	
5076	13D4							Output B Peak voltage protection margin	RW	float	4	2	FP IEEEE754	
5078	13D6							Output C Peak voltage protection margin	RW	float	4	2	FP IEEEE754	

Modbus App

Modbus address (dec)	Modbus address (hex)	Read coils	Read holding registers	Read input registers (0x06)	Write single coil (0x05)	Write single register (0x06)	Write multiple registers (0x10)	Description	Access	Data type	Data length in bytes	Number of registers	Data	Example
5080	13D8							Peak voltage protection level	RW	float	4	2	FP IEEE754	
5082	13DA							Output A Peak voltage protection level	RW	float	4	2	FP IEEE754	
5084	13DC							Output B Peak voltage protection level	RW	float	4	2	FP IEEE754	
5086	13DE							Output C Peak voltage protection level	RW	float	4	2	FP IEEE754	
5088	13E0							Peak voltage protection mode	RW	uint(16)	2	1	unsgnd int 16b	0=MARGIN, 1=LEVEL, 2=MARGIN & LEVEL
5090	13E2							Output A Peak voltage protection mode	RW	uint(16)	2	1	unsgnd int 16b	
5092	13E4							Output B Peak voltage protection mode	RW	uint(16)	2	1	unsgnd int 16b	
5094	13E6							Output C Peak voltage protection mode	RW	uint(16)	2	1	unsgnd int 16b	

Configuration Slew	6000	1770						Ramp time	RW	float	4	2	FP IEEE754	0.222 Seconds
	6002	1772						Output A Ramp time	RW	float	4	2	FP IEEE754	
	6004	1774						Output B Ramp time	RW	float	4	2	FP IEEE754	
	6006	1776						Output C Ramp time	RW	float	4	2	FP IEEE754	
	6008	1778						Voltage AC	RW	float	4	2	FP IEEE754	
	6010	177A						Output A Voltage AC	RW	float	4	2	FP IEEE754	

Modbus App

Modbus address (dec)	Modbus address (hex)	Read coils	Read holding registers	Read input registers (0x06)	Write single coil (0x05)	Write single register (0x06)	Write multiple registers (0x10)	Description	Access	Data type	Data length in bytes	Number of registers	Data	Example
6012	177C							Output B Voltage AC	RW	float	4	2	FP IEEE754	
6014	177E							Output C Voltage AC	RW	float	4	2	FP IEEE754	
6016	1780							Frequency	RW	float	4	2	FP IEEE754	
6018	1782							Output A Frequency	RW	float	4	2	FP IEEE754	
6020	1784							Output B Frequency	RW	float	4	2	FP IEEE754	
6022	1786							Output C Frequency	RW	float	4	2	FP IEEE754	
6024	1788							Voltage DC	RW	float	4	2	FP IEEE754	
6026	178A							Output A Voltage DC	RW	float	4	2	FP IEEE754	
6028	178C							Output B Voltage DC	RW	float	4	2	FP IEEE754	
6030	178E							Output C Voltage DC	RW	float	4	2	FP IEEE754	
6032	1790							Phase	RW	float	4	2	FP IEEE754	
6034	1792							Output A Phase	RW	float	4	2	FP IEEE754	
6036	1794							Output B Phase	RW	float	4	2	FP IEEE754	
6038	1796							Output C Phase	RW	float	4	2	FP IEEE754	
6040	1798				x			Slew rate control	RW	bool				
6041	1799				x			Output A Slew rate control	RW	bool				
6042	179A				x			Output B Slew rate control	RW	bool				
6043	179B				x			Output C Slew rate control	RW	bool				

Configuration	8000	1F40						Configuration form	RW	uint(16)	2	1	unsngnd int 16b	1=SINGLE, 2=SPLIT, 3=THREE
Unit	8001	1F41						Configuration voltage range	RW	uint(16)	2	1	unsngnd int 16b	0=LOW, 1=HIGH

Modbus App

Settings

Modbus address (dec)	Modbus address (hex)	Read coils	Read holding registers	Read input registers (0x06)	Write single coil (0x05)	Write single register (0x06)	Write multiple registers (0x10)	Description	Access	Data type	Data length in bytes	Number of registers	Data	Example
8002	1F42							Configuration mode	RW	uint(16)	2	1	unsgnd int 16b	0=AC, 1=DC 2=AC-DC
8003	1F43							Phase rotation	RW	uint(16)	2	1	unsgnd int 16b	0=NEGATIVE, 1=POSITIVE
8004	1F44							Output impedance mode	RW	uint(16)	2	1	unsgnd int 16b	0=REAL TIME, 1=RMS
8005	1F45							Output A impedance mode	RW	uint(16)	2	1	unsgnd int 16b	
8006	1F46							Output B impedance mode	RW	uint(16)	2	1	unsgnd int 16b	
8007	1F47							Output C impedance mode	RW	uint(16)	2	1	unsgnd int 16b	
8016	1F50							Update phase	RW	float	4	2	FP IEEE754	
8018	1F52							Output A update phase	RW	float	4	2	FP IEEE754	
8020	1F54							Output B update phase	RW	float	4	2	FP IEEE754	
8022	1F56							Output C update phase	RW	float	4	2	FP IEEE754	
8024	1F58							Output phase disable	RW	float	4	2	FP IEEE754	
8026	1F5A							Output A phase disable	RW	float	4	2	FP IEEE754	
8028	1F5C							Output B phase disable	RW	float	4	2	FP IEEE754	
8030	1F5E							Output C phase disable	RW	float	4	2	FP IEEE754	
8032	1F60							Max CSC gain	RW	float	4	2	FP IEEE754	
8034	1F62							Output A max CSC gain	RW	float	4	2	FP IEEE754	
8036	1F64							Output B max CSC gain	RW	float	4	2	FP IEEE754	
8038	1F66							Output C max CSC gain	RW	float	4	2	FP IEEE754	
8048	1F70	x			x			Continuous self calibration	RW	bool				

Modbus App

Modbus address (dec)	Modbus address (hex)	Read coils	Read holding registers	Read input registers (0x06)	Write single coil (0x05)	Write single register (0x06)	Write multiple registers (0x10)	Description	Access	Data type	Data length in bytes	Number of registers	Data	Example
8049	1F71	x			x			Output A continuous self calibration	RW	bool				
8050	1F72	x			x			Output B continuous self calibration	RW	bool				
8051	1F73	x			x			Output C continuous self calibration	RW	bool				
8052	1F74	x			x			Fault on saturation	RW	bool				
8053	1F75	x			x			Output A fault on saturation	RW	bool				
8054	1F76	x			x			Output B fault on saturation	RW	bool				
8055	1F77	x			x			Output C fault on saturation	RW	bool				

SCPI	6400 0	FA00						SCPI Write/query	RW	char	246	123	ASCII	MEASure : VOLTage : DC:NC#?
	6425 6	FB00						SCPI Command last answer			1024	512	ASCII	0.000,0 .000 0.000,0 .000
	6476 9	FD01	x		x			SCPI Char 16 endianness	RW	bool			Coils : Endianness	OFF= little, ON= Inverted
	6477 0	FD02	x		x			SCPI Response next page	RW	bool			Coils : Next Page	ON=next, self clear

14.3 ModBus Control Example using Python

For those not familiar with using the ModBus TCP protocols, the example code shown here using Python may be of assistance in getting started.

Note: The example code named “modbustcp-example-1.py” referenced below is available for download at the following link in the ‘python’ directory:

https://github.com/PPST-Inc/ModbusTCP_Examples

This example code performs the following tasks in the order shown below.

```
> python.exe modbustcp-example-1.py
Enter the IP address of the unit: 192.168.107.183
Connecting
Setting voltage AC to 0 Vrms
Setting frequency to 50 Hz
Turning output on...
Setting voltage AC to 30 Vrms
Reading RMS voltage measurement
Voltage RMS measurement: 29.93 Vrms
Reading RMS current measurement
Current RMS measurement: 2.74 Arms
Turning output off
Disconnecting
Done
```

The dependencies and requirements to run the sample code are shown in the program comments and are:

```
# PPST ModbusTCP python example 1
# Version: 1.0.0
# Date: 11/07/2022
# Dependences:
# - pip install pymodbus
# - pip install pyModbusTCP
# Last tested with:
# - Python 3.10.5
# - pymodbus 3.0.2
# - pyModbusTCP 0.2.0
```

More advanced samples can be found using the link referenced above.

15 CE MARK Declaration of Conformity

The Manufacturer hereby declares that the products:

Product Name: AFX Series & ADF Series® Power Sources, All Models in Series

Conforms to the following standards or other normative documents:

RoHS (DIRECTIVE 2011/65/EU)

Standard applied EN IEC 63000:2018

SAFETY (DIRECTIVE 2014/35/EU):

Standard applied EN 61010-1: 2010; ED3/A1:2019

EMC (DIRECTIVE 2014/30/EU):

Standard applied EN 61326-1: 2013

Reference Standards:

ELECTROMAGNETIC EMISSIONS:

Radiated Emissions CISPR 11/22, CLASS A LIMITS
Conducted Emissions CISPR 11/22, CLASS A LIMITS

ELECTROMAGNETIC IMMUNITY:

RF Electromagnetic Field IEC 61000-4-3:2006+A1:2007+A2:2010
80 – 1000 MHz, 10 V/m
1 Khz sinewave (80% AM) 1.4 – 2 GHz, 3 V/m
2.0 – 2.7 GHz, 1 V/m

Conducted RF Immunity IEC 61000-4-6:2013
Conducted RF Immunity 0.15 – 80 MHz @ 3 Vrms

Electrostatic Discharge IEC 61000-4-2:2008
± 4 kV contact discharge
± 8 kV air discharge

Electrical Fast Transient/Burst IEC 61000-4-4:2004+A1:2010
AC or DC power ports, ± 2.0 kV
Signal and I/O ports, ± 1.0 kV

Surge IEC 61000-4-5:2006
AC or DC power ports, ± 2.0 kV Line to ground and ± 1.0 kV Line to Line

Power Frequency Magnetic Field IEC 61000-4-8:2009
30 A/m

Supplemental Information:

When and Where Issued September 28, 2022
Irvine, California, USA

Authorized Signatory 
Mitchel Orr,
Quality Manager, acting
Pacific Power Source

Responsible Person Mitchel Orr,
Pacific Power Source, Inc.
2802 Kelvin Ave, Suite 100
Irvine CA, 92614 - USA

Mark of Compliance



Index

A

AC input.....	57
AC Input	41, 61
AC terminal block.....	60
accessories	
included	26
Accessories.....	26
AFXS system	159
air filter	66
Airflow.....	63

B

Browser	427
Remote Interface.....	482

C

Cabinet	
Options	90
Calibration	490
Commands.....	232
CE MARK.....	537
Circuit Breaker	62
CONFIGURATION	
Screens	156
Configuration Settings.....	158
Connections	199
Console	
SCPI	189
Contact.....	15, 79, 521
Contents.....	3
CSC Configuration.....	166
CSV files	
Transient List Import/Export.....	443
Cycle Reset.....	167

D

Date formats.....	386
Decimal separator.....	386

E

E Version.....	29, 47
Emergency	
Power Off option	91
Energy Savings Modes.....	114
equipment weight.....	55
Error and Event queue.....	173
Error Messages.....	497
Ethernet.....	100
Access Control.....	429
Export Version.....	29, 47
External Voltage Sense	201

F

Fault Queue.....	173
Features.....	24
File Manager.....	192
Filter	
Air Intake	66
Firmware Update.....	197
FORM	121
front panel operation.....	111

G

Grounding	
Cabinet Systems	84

I

Import	
Transient List	443
Installation.....	16, 55, 425
Interface	
Ethernet	100
Ethernet Browser.....	427
GPIB Settings	184
I/O Settings	184
LAN100	
Monitor	113
Remote Inhibit Settings	185
RS232 Settings.....	182
Screens.....	174
USB Settings	183

K

Keyboard	112
Touchscreen.....	177
KIT.....	63

L

LAN	
Access Control.....	429
Browser Interface	427
Configuration	427
Setup.....	180
LAN Configuration.....	427
LAN.....	100
LCD Image	
capture to image file	112
Logging measurement data	139

M

Maintenance	
Air Filter Cleaning	65
Managing	
Files192	
Manual	438

Measurement Command		Remote Control	229
Resolution Setting	252	RS232	
Measurements		Interface	182
Datalogger	137	S	
MEASUREMENTS		safety information	16
Logging	198	Safety Information	16
Screen	134	Safety Notices	18
Soft Keys	137	SCIP Console	189
Memory		Screen capture	
SD Card	113	LCD Image	485
USB113		SD Card	113
Memory Management	191	Sense Terminals	201
Menus	115	Series Connection	
ModBus		AFX Models	49, 159
TCP	522	Service	520
O		Shuttle	112
optional output transformer	159	Size 200	
options	26	Slew Rates	163
Output		Specifications	27
Control Switch	90	Start Phase	158
Enable Button	112	Stop Phase	159
Impedance	168	SYSTEM	
Relay Control	99	Screens	171
Remote Inhibit	98	system bus	101
Response Time	114	system interface	100
Output Enable	114	System Interface	228
Output Impedance	168		
P		T	
Parallel Operation	100, 101	T Option	159
Phase Angle		Terminals	199
Control	158	Terminator Characters	231
Phase Mode	121	Test Sequences	
phase rotation		Browser Interface	456
positive or negative	160	SCPI Commands	410
Phase rotation	118	Tools Required	
Powering Up	79	Cabinets	80
Presets		Touchscreen Keyboard	177
Output Parameters	119	Transformer	
Program		Option	77, 283, 365
Impedance	168	Transient Settings	167
PROGRAM		TRANSIENTS	
Screen	116	Screens	140
Soft Keys	122	Turn on	79
Program Data Entry	119	U	
Program Memory	165	UNIT INFORMATION	187
Programming	111, 229	unpacking	55
Conventions	229	Update Phase	158
Terminators	231	USB	
Protection	38	Drivers	425
R		USB	94
Rear Panel		User Limits	162
Connector Locations	93	User Presets	169
Recommended Wire Sizing	67		
Regional setting	386		

V

Video Monitor	113
Virtual Front Panel	
Browser	482
voltage sense	
External	78
Internal.....	78

W

Warranty	16
Waveform	
Library	126
Weight.....	41
Wire Size.....	200
Wire Sizing	
Recommended.....	67



Pacific Power Source

The Power of Expertise